

Grant Aeron R290

Air to Water Air Source Heat Pump Range

Installation & Operating Instructions

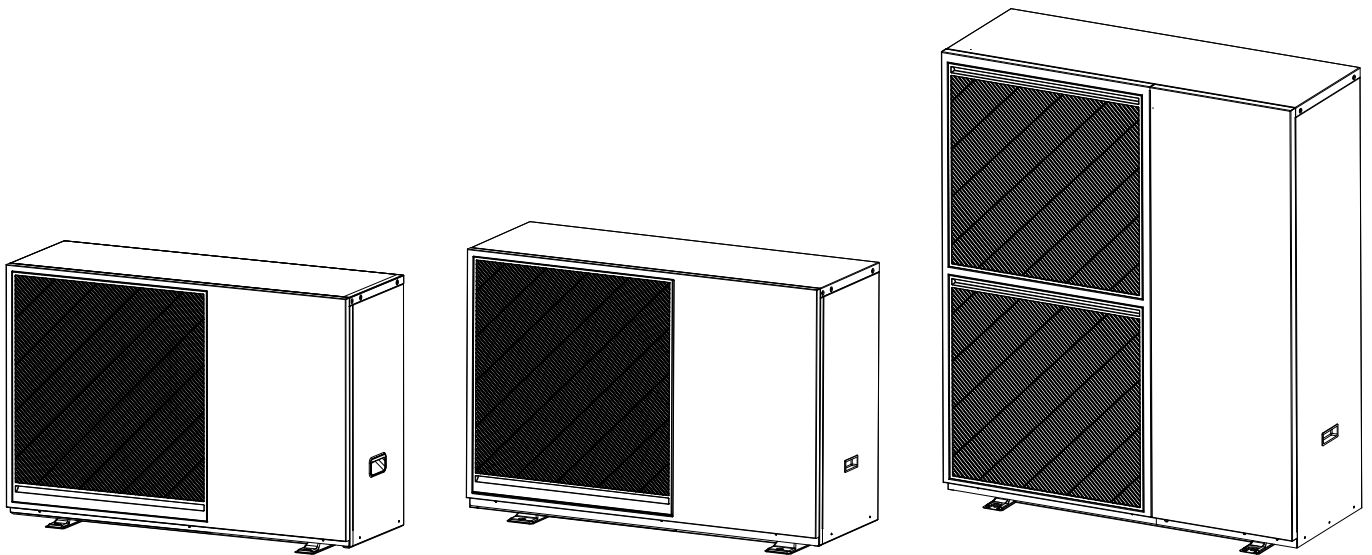

IMPORTANT NOTE FOR INSTALLERS

These instructions are intended to guide installers on the installation and commissioning of the Grant Aerona R290. After installing the unit, leave these instructions with the user.

SPECIAL TEXT FORMATS

The following special text formats are quite important and are used in these instructions for the purposes listed below:

! WARNING !

Warning of possible human injury as a consequence of not following this instruction.

! CAUTION !

Caution concerning likely damage to equipment or tools as a consequence of not following this instruction.

! NOTE !

Used for emphasis or information not directly concerned with the surrounding text but of importance to the reader.

Power Quality Information

HPR290i40	Complies with the Technical requirements of BS EN/IEC 61000-3-2
HPR290i65	
HPR290i90	Complies with the Technical requirements of BS EN/IEC 61000-3-3
HPR290i120	
HPR290i160	Complies with BS EN/IEC 61000-3-11 & BS EN/IEC 61000-3-12

This appliance can be used by children aged from 8 years and above and persons with reduced physical, sensory or mental capabilities or lack of experience and knowledge if they have been given supervision or instruction concerning use of the appliance in a safe way and understand the hazards involved. Children shall not play with the appliance. Cleaning and user maintenance shall not be made by children without supervision.



GRANT ENGINEERING (IRELAND) ULC

Crinkle, Birr, Co Offaly

R42 D788, Ireland

www.grant.eu

Email: info@grant.ie

Tel: +353 (0)57 91 20089

This manual is accurate at the date of printing but will be superseded and should be disregarded if specifications and/or appearances are changed in the interests of continued product improvement.

However, no responsibility of any kind for any injury, death, loss, damage or delay however caused resulting from the use of this manual can be accepted by Grant Engineering (Ireland) ULC, the author or others involved in its publication.

All goods sold are subject to our official Conditions of Sale, a copy of which may be obtained on application.

© Grant Engineering (Ireland) ULC No part of this manual may be reproduced by any means without prior written consent.

SERVICE

The heat pump should be serviced at least every twelve months and the details entered in the Service Log in the back of the manual.

PRODUCT CODES AND SERIAL NUMBERS COVERED

The serial numbers used on the product consist of a 15 digit numerical code with the central three digits being the product identifier.

For example:



This serial number can be found on a label attached to the unit on its rear left-side panel (viewed from the rear above the flow and return connections) and will be used when registering the heat pump with Grant.

These instructions cover the following product codes and serial numbers:

Product code	Serial number identifier
HPR290i40 - 4kW	612
HPR290i65 - 6.5kW	613
HPR290i90 - 9kW	614
HPR290i120 - 12kW	615
HPR290i160 - 16kW	616

The manufacturer serial is a 31 digit alpha-numeric code found on a label next to the serial number. This is used for manufacturing purposes only but should be left attached to the unit.



Grant Aerona HPR290i40	
Model	HPR290i40
Power Supply	230V 1PH 50Hz
Heating Capacity*	4.0 kW
COP*	3.15
Maximum Current (Heating)	19A
Refrigerant	R290
Mass of Refrigerant	610g
GWP	3
Equivalent CO ₂	0.002t
Rated Water Flow	0.69m ³ /h / 11.5 l/min
Net Weight	101kg
Height	803mm
Length	1155mm
Depth	422mm
Max System Pressure	3 bar
Max Pressure - Suction	0.3 MPa
Max Pressure - Discharge	3.5 MPa
Waterproof Level	IPX4
* Air 7°C / Water 55°C	
Grant Engineering www.grant.eu	

IMPORTANT NOTE FOR INSTALLERS

The data label gives you very important information about the installed heat pump. Do not remove this label from the heat pump under any circumstances.

CONTENTS

1	INTRODUCTION	4			
1.1	General	4	9.3	Settings	52
1.2	Main Components	4	9.4	Temperature Control	53
1.3	Planning Permission	4	9.5	Flow	53
1.4	DNO Application	5	9.6	Balancing the Primary Circuit	53
1.5	Customer Support Centre	5	10	SERVICING	54
1.6	Important Advice	5	10.1	Safety	54
1.7	Product Contents	5	10.2	Servicing & Maintenance Procedure	55
1.8	Remote Controller Kits	6	10.3	Condensate Disposal	56
1.9	Installation Packs & Accessories	6	10.4	Heating System Connections	56
1.10	Heat Pump Components	7	10.5	Heat Pump Controls	56
1.11	Hydraulic Module	10	10.6	Refrigerant	56
			10.7	Heat Pump Monitoring	56
			10.8	Maintenance and Service	56
2	TECHNICAL DATA	12	10.9	Hydraulic PCB Dip Switches	56
2.1	Heat Pump Technical Data	12	11	FAULT FINDING	58
2.2	Heat Pump Dimensions	13	12	SPARE PARTS	62
3	INSTALLATION INFORMATION	15	12.1	Spare Parts 4kW, 6.5kW, 9kW, 12kW, 16kW	62
3.1	Before Installation	15	13	DECLARATION OF CONFORMITY	71
3.2	Introduction	17	13.1	Safety Declaration of Conformity	71
3.3	Regulations	18	14	PRODUCT FICHE	72
3.4	Heat Pump Location	18	14.1	HPR290i40 Fiche	72
3.5	Preparation for Installation	19	14.2	HPR290i65 Fiche	74
3.6	Protective Zones	19	14.3	HPR290i90 Fiche	74
3.7	Installing the Heat Pump	23	14.4	HPR290i120 Fiche	75
3.8	System Volume Requirements	24	14.5	HPR290i160 Fiche	76
3.9	Hydraulic Diagrams	25	15	HEALTH & SAFETY INFORMATION	77
3.10	Aerona Smart Controller	25	15.1	General	77
3.11	Before you Commission	25	14.2	Refrigerant (R290)	77
3.12	Antifreeze Valves	25	16	DISPOSAL AND RECYCLING	78
3.13	Completion	26	17	GUARANTEE	79
3.14	Installation Checklist	26	18	USER INSTRUCTIONS	81
3.15	Aerona R290 Packaging	26	18.1	User Instructions	81
3.14	R290 Heat Pump Installatin Schematic	27	18.2	About your Heat Pump	81
4	SEALED SYSTEMS	31	18.3	Aerona Smart Controller	81
4.1	Introduction	31	18.4	Powering Heat Pump On/Off	81
4.2	Filling the Sealed System	31	18.5	Aerona Smart Controller Display	82
4.5	Draining the Water Circuit	32	18.6	Heating System Controls	82
4.3	Pressure Relief (Safety) Valve Operation	32	18.7	Anti-Legionella Protection	83
4.4	Water Circuit Connection	32	18.8	Frost Protection	83
5	DOMESTIC HOT WATER	33	18.9	Looking after your Heat Pump	83
5.1	Temperature Control	33	18.10	Troubleshooting	83
5.2	Grant Cylinders	33	APPENDIX A CIRCULATION PUMP GPA25-9HW	84	
5.3	Legionella	33	A.1	Circulation pump GPA25-9HW PWM Pump	84
6	ELECTRICAL	34	A.2	Pump Interface	85
6.1	Power Supply	34	ONLINE RESOURCES	85	
6.2	Tightening Torques	37		Aerona Smart Controller - How to Playlist	85
6.3	Connection of Controller	37	SERVICE LOG	86	
6.4	Internal Electric Heaters	37			
6.5	Wiring Centre Layout	38			
6.6		39			
6.7	System Wiring Diagrams	40			
7	SMART CONTROLLER (SEE SMART CONTROLLER MANUAL)	50			
7.1	Grant Aerona Smart Controller	50			
7.2	Installation Requirements	50			
7.3	Connecting Smart Controller the to Heat Pump	50			
7.4	Smart Controller Operation	50			
8	OPERATION	51			
9	COMMISSIONING	52			
9.1	System Setup	52			
9.2	System Configuration	52			

1 INTRODUCTION

1.1 GENERAL

The Grant Aerona R290 Air to Water Air Source Heat Pump range consists of five models. These are all MCS approved, air-to-water, inverter driven, single-phase air source heat pumps working with R290 refrigerant.

The Grant Aerona R290 extracts heat from the outdoor air and it is transferred through the refrigerant piping to the plate heat exchanger in the hydraulic system. The heated water in the hydraulic system circulates to the heat emitters to provide space heating. This water is also used to heat the domestic hot water cylinder. The 4-way valve in the Grant Aerona R290 can reverse the refrigerant cycle to prevent ice formation in the plate heat exchanger.

The heating capacity of the unit decreases with ambient temperature. The nominal outputs e.g. 4 kW is the heating capacity at an ambient temperature of -5°C with a flow 55°C.

It is important that these instructions are followed to ensure correct installation and operation of the heat pump. Failure to do so may result in poor performance of the installed unit or system.

These instructions do not replace the installation or users manuals for any additional components used in the design of your system e.g. cylinders, motorised valves, programmers, solar thermal devices, buffers, etc.

The Grant Aerona R290 heat pump is to be used only with the Grant Aerona Smart heat pump system controller which is obtained either as a stand alone kit (purchased from Grant) or supplied factory-fitted and pre-wired to a Grant Smart Pre-Plumbed cylinder. Refer to Section 1.7 for further information.

These units are used for heating applications and domestic hot water cylinders. They can be combined with fan convector units, underfloor heating, low temperature high efficiency radiators, domestic hot water cylinders and solar thermal systems.

These instructions must be left with the product for future reference.

1.2 MAIN COMPONENTS

Each model incorporates the following main components:

- **DC inverter** - This responds rapidly to changing conditions to provide the necessary output to meet heating demands by varying the speed and output of the compressor, fan and indirectly the circulating pump. This reduces the on/off times of the compressor, keeping the water temperature constant during operation reducing the electricity consumption.
- **Compressor** - a high-efficiency DC twin-rotary compressor to provide smooth performance and quiet operation.
- **Plate heat exchanger (condenser)** - The high efficiency plate heat exchanger is used to transfer heat to the heating system primary circuit.
- **Fan** - a high-efficiency DC fan motor is used for smooth and quiet operation. A single fan (3 blade) is fitted to the HPR290i40, HPR290i65 & HPR290i90, and two fans (3 blade) are fitted to the HPR290i120 and HPR290i160 units.
- **Circulating pump** - high-efficiency PWM pump speed controlled from the ASHP Hydraulic PCB.
- **Base tray heater** - factory fitted electric heater to melt any frozen condensate collected in the base of the heat pump. When the ambient temperature reaches -5°C, the base tray heater turns on and will remain on for either 60 minutes or when the ambient temperature reaches -2°C (ΔT of 3K). These temperatures are factory set and cannot be adjusted by the user.
- **Electronic expansion valve (EEV)** - Controls refrigerant flow and reduces refrigerant pressure.
- **4-way valve** - Controls refrigerant flow direction. Closed in cooling mode and open in heating mode. When closed, the air side heat exchanger functions as a condenser and water side heat exchanger functions as an evaporator, when open, the air side heat exchanger functions as an evaporator and water side heat exchanger functions as a condenser.

- **High pressure switch** - Monitors refrigerant system pressure. When refrigerant system pressure rises above the upper limit, the high pressure switches will open and then turn off heat pump.
- **High pressure sensor** - Monitors refrigerant system pressure. When refrigerant system pressure rises above the upper limit, the high pressure sensor will open and then reduce compressor operating frequency.
- **Low pressure sensor** - Monitors refrigerant system pressure. When refrigerant system pressure falls below the lower limit, low pressure sensor detects the limit value and then turns off heat pump.
- **Pressure relief valve** - A 3 bar pressure relief valve is factory fitted in the heating primary circuit of the heat pump.
- **Air purge valve (automatic air vent)** - Factory fitted to assist in the removal of air from the heating primary circuit of the heat pump.
- **Water flow switch** - Detects water flow rate to protect compressor and water pump in the event of insufficient water flow.
- **Built-in electric heater** - Provides anti-freeze protection for the plate heat exchanger and adjacent pipework in the heat pump. This will not provide antifreeze protection to the entire system.

1.3 PLANNING PERMISSION

In Northern Ireland, the installation of a The Grant Aerona R290 Air to Water Air Source Heat Pump Range on domestic premises may be considered to be permitted development, not needing an application for planning permission, provided ALL the limits and conditions listed on the Planning Portal website are met.

1.4 DNO APPLICATION

In Northern Ireland, Grant recommend using the ENA "Connect Direct" to make sure you can connect the heat pump to the customers electrical connection. It is a simple process that requires the installer to set up an account, either as an individual or as a company.

Connect Direct is a national platform created by the seven UK Distribution Network Operators (DNOs) and the Energy Networks Association (ENA). It is used for getting approval to retrofit low-carbon technology (LCT) devices - both generation and demand - to existing residential properties. It streamlines and standardises the application process for all DNOs across GB and NI. Connect Direct is also used by LCT manufactures, like Grant. They use it to register their inverters, EV charger, and Heat pumps, thereby making them available to installers to select when submitting an application.

The "Connect Direct" system has been designed to simplify the application process for installers. It uses a data-driven decision engine to assess applications. The checks made are to ensure that:

- There are no safety concerns with the cut-out fuse, or other equipment.
- There is no uncertainty over the supply capacity or the adequacy of the supply.
- The property is not on a looped supply.
- The connection does not require an upgrade
- The max demand of the property is within the supply capacity and DNO-defined thresholds for approval.
- The equipment is compliant.
- The equipment is within DNO-defined thresholds.

If all checks pass, the application will be auto-approved in real-time for you. If not, the application will be escalated to the DNO for review. Any updates will be communicated to you via Connect Direct.

Each DNO configures the threshold levels within which they are happy to auto-approve applications. These may vary geographically.

To make an application, or to set up an account, follow the procedure set out by the Energy Networks Association (ENA).

Full details on application/notification process can be found by scanning the following QR code. Refer to Table 1-1 for details.

Table 1-1: Connect direct QR code

QR Code	Link
	https://connect-direct.energynetworks.org/

Table 1-2: Product Contents

Output	HPR290i40	HPR290i65	HPR290i90	HPR290i120	HPR290i160
4kW	1				
6.5kW		1			
9kW			1		
12kW				1	
16kW					1
Items					
Condensate drain elbow	3	3	3	3	3
Cable glands	3	3	3	3	3
Crimp ring Terminal fittings	6	6	6	6	6
ERP Label	1	1	1	1	1
R290 Installation & User instructions	1	1	1	1	1

1.5 CUSTOMER SUPPORT CENTRE

Grant provides an online support centre for Heating Professionals and Homeowners to access post-installation care, advice and maintenance support for Grant products. Follow the QR codes below to access your relevant Customer Support Centre.



Homeowner



Professional

1.6 IMPORTANT ADVICE

1. It is essential that the full layout of the system is understood before the installation of any component is undertaken. If you are in any doubt, please stop and seek advice from a qualified heating engineer or from Grant. Please note that Grant will not be able to offer specific advice about your system unless we designed it. In this case, we will always refer you to seek the advice of a qualified system designer.
2. The heat pump must be installed and commissioned in accordance with these installation and operating instructions. Deviations of any kind will invalidate the guarantee and may cause an unsafe situation to occur. Please seek advice from Grant if any of these user, installation and servicing instructions cannot be followed for whatever reason.
3. The heat pump contains high pressures and high temperatures during normal working conditions. Care must be taken when accessing the internal workings of the heat pump.
4. The heat pump contains an electrically driven fan which rotates at high speed. Disconnect the heat pump from the electrical supply before removing the top cover.

1.7 PRODUCT CONTENTS

The Aerona R290 comes supplied on a single pallet. The items that are included are indicated in Table 1-2.

1.8 REMOTE CONTROLLER KITS

1.8.1 GRANT AERONA SMART CONTROLLER

The Grant Aerona R290 is designed to work exclusively with the Grant Aerona Smart heat pump system controller.

If you are using a Grant Smart Pre-plumbed cylinder with the Aerona R290, you will receive the installation instructions manual with the cylinder, which will contain all the information related to Smart Controller.

Table 1-3: Smart controller kits

Product code	Description
HP290SMART	Smart controller kit for Aerona R290 with a standard cylinder containing: <ul style="list-style-type: none">• Smart Controller Wiring Centre• Smart Controller Touchscreen display• Wi-Fi Hub• Outdoor Weather Sensor• 1 x Water Temperature Sensor• 2 x Flexible Hoses• 2 x Isolation Valves
HP290SMARTPP	Smart controller kit for Aerona R290 with a Grant Smart Pre-plumbed cylinder containing: <ul style="list-style-type: none">• Wi-Fi Hub• Outdoor Weather Sensor• 2 x Water Temperature Sensors• 2 x Flexible Hoses• 2 x Isolation Valves

1.9 INSTALLATION PACKS & ACCESSORIES

The following are available from Grant:

Table 1-4: Installation packs and accessories

Product code	Description
HPIDVOL50	50 litre Internal volumiser available as an optional component where there is insufficient system volume.

! NOTE !

The Grant Aerona R290 is designed exclusively for domestic or semi-domestic purposes. This means that even users without prior experience should be able to operate the Grant Aerona R290 safely.

! NOTE !

Improper installation of equipment or accessories can result in electric shock, short circuit, leakage, fire, or other damage to the equipment. It is important to use only accessories that are made by the supplier and are specifically designed for the equipment.

1.10 HEAT PUMP COMPONENTS

1.10.1 HPR290i40

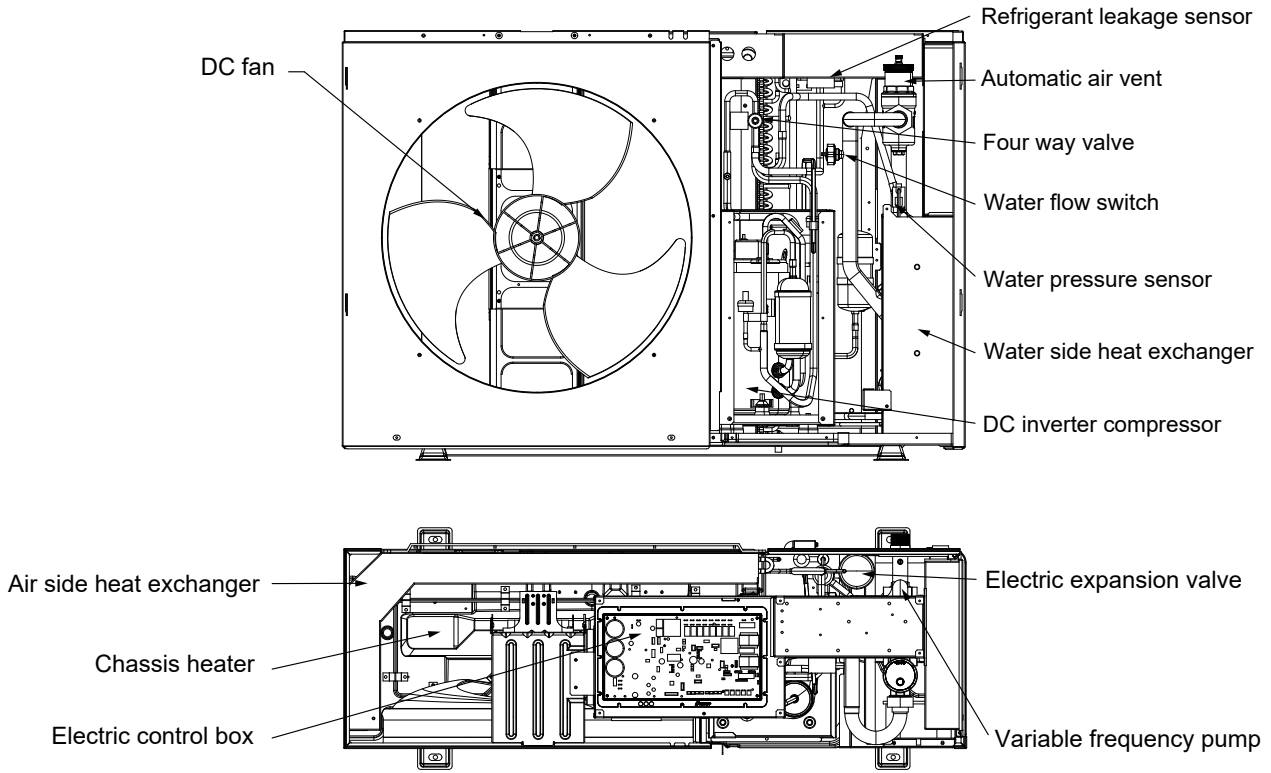

Figure 1-1: Main components - HPR290i40

1.10.2 HPR290i65 & HPR290i90

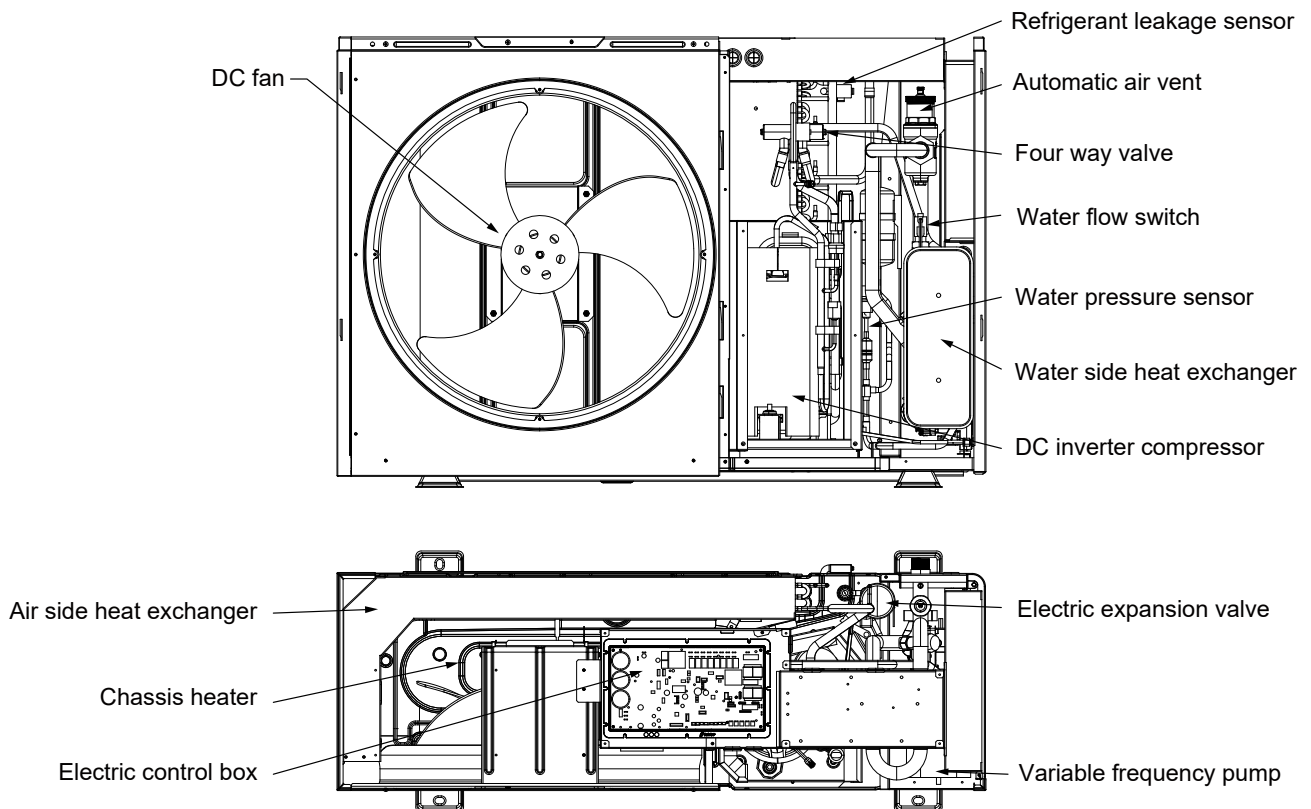

Figure 1-2: Main components - HPR290i65 & HPR290i90

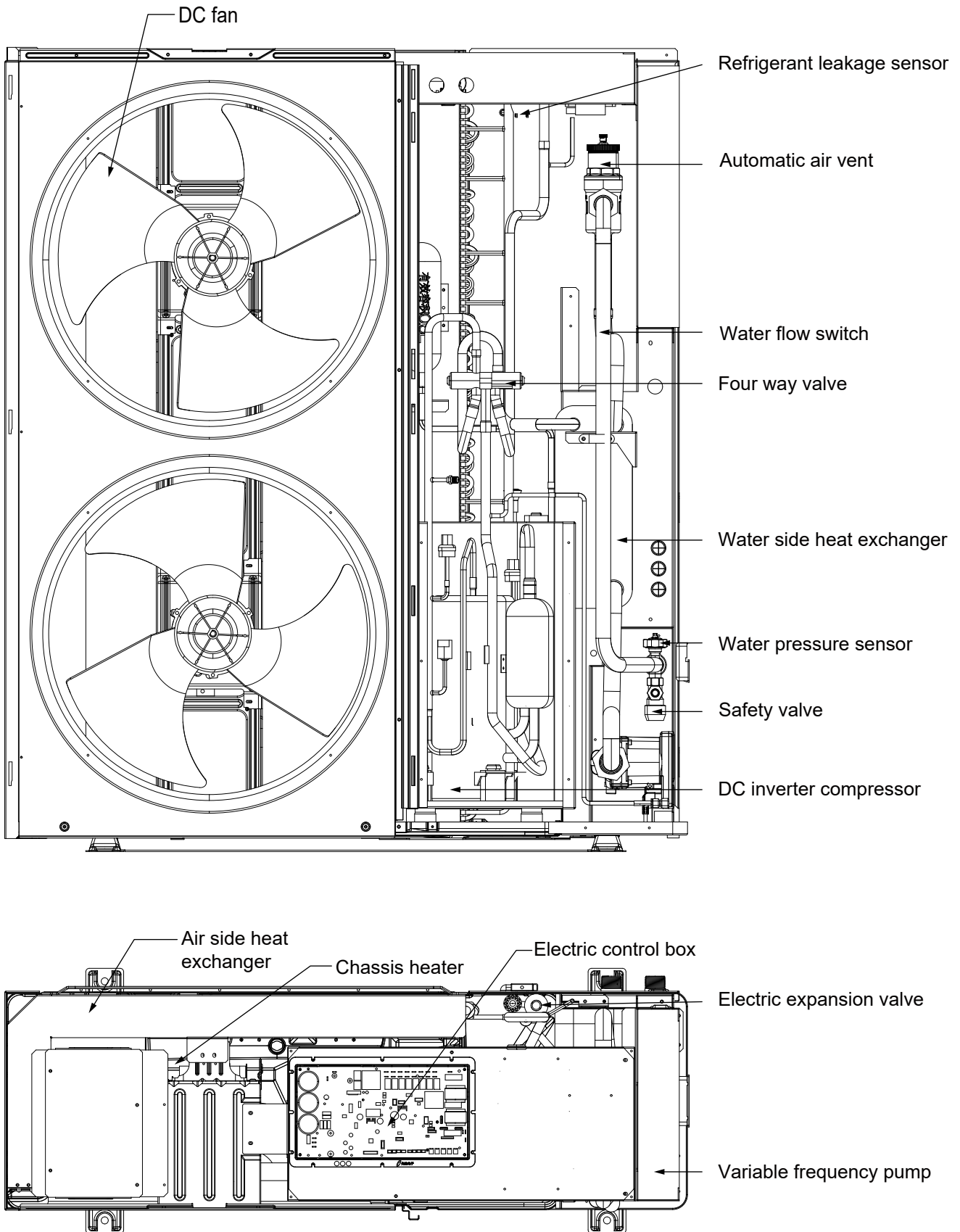

Figure 1-3: Main components - HPR290i120

1.10.4 HPR290i160

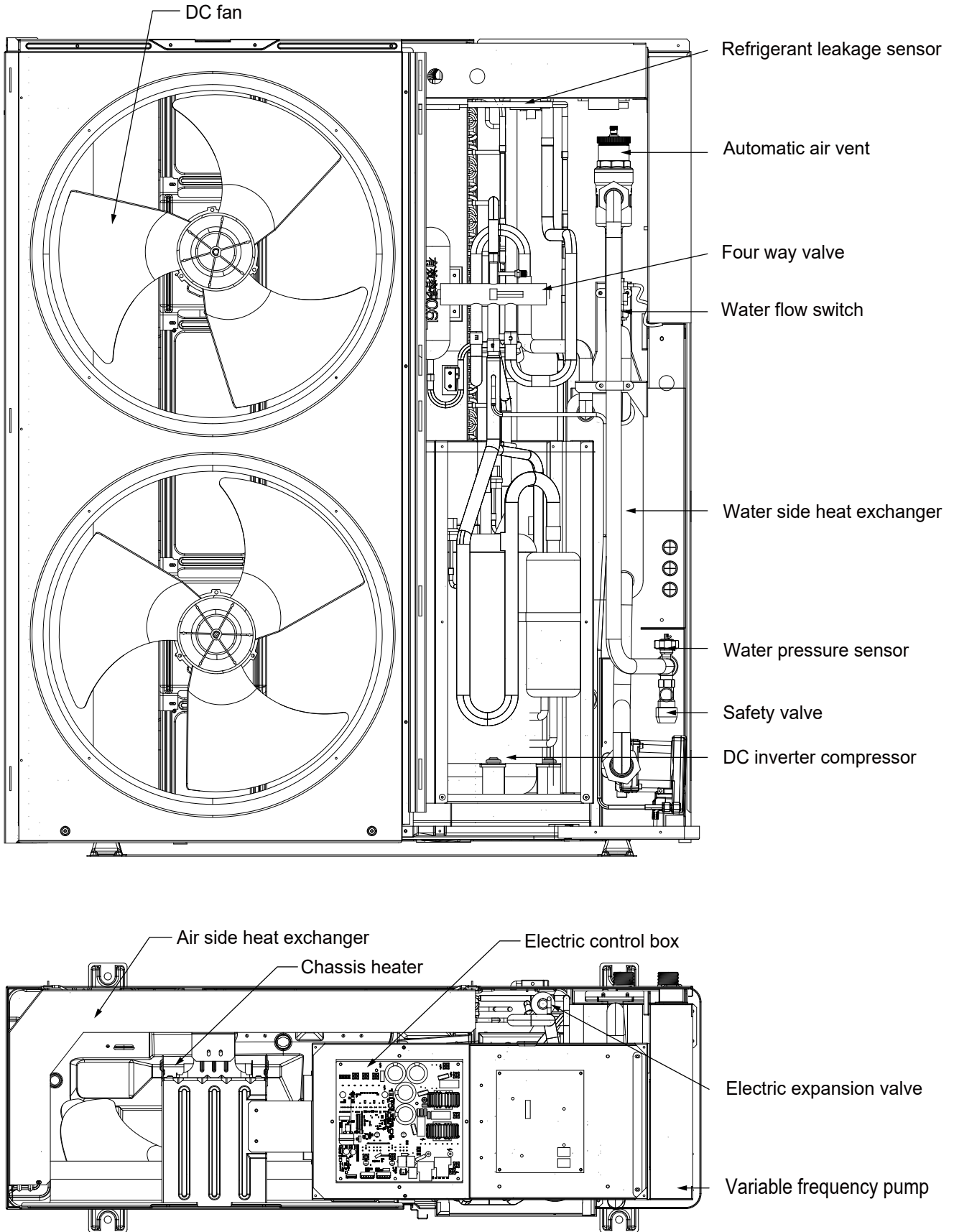

Figure 1-4: Main components - HPR290i160

1.11 HYDRAULIC MODULE

Components of the hydraulic module of each unit model:

1.11.1 HPR290140

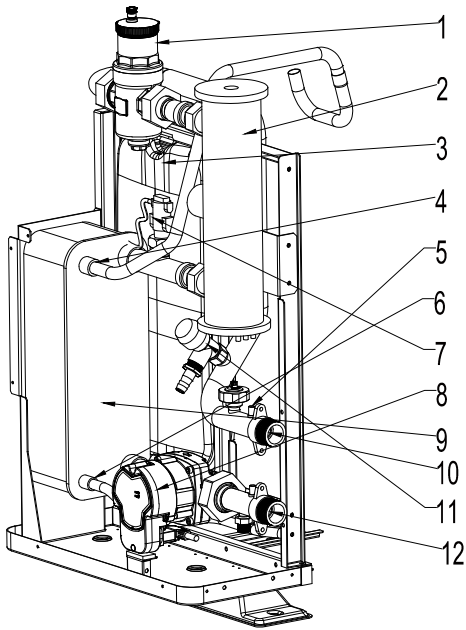

Figure 1-5: Hydraulic module - 4kW

1.11.3 HPR290190

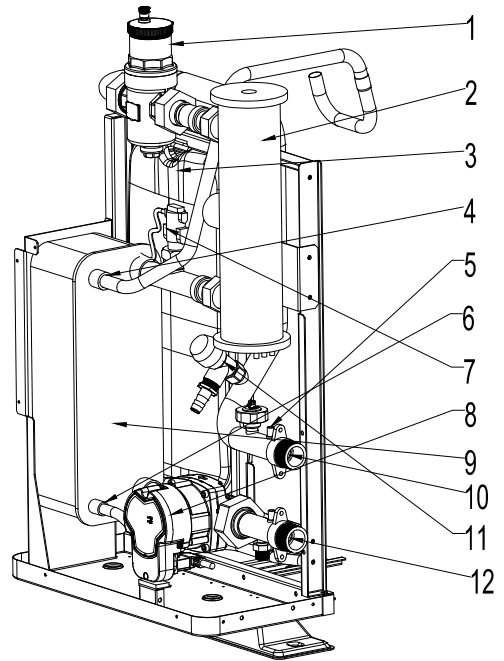

Figure 1-7: Hydraulic module - 9kW

1.11.2 HPR290165

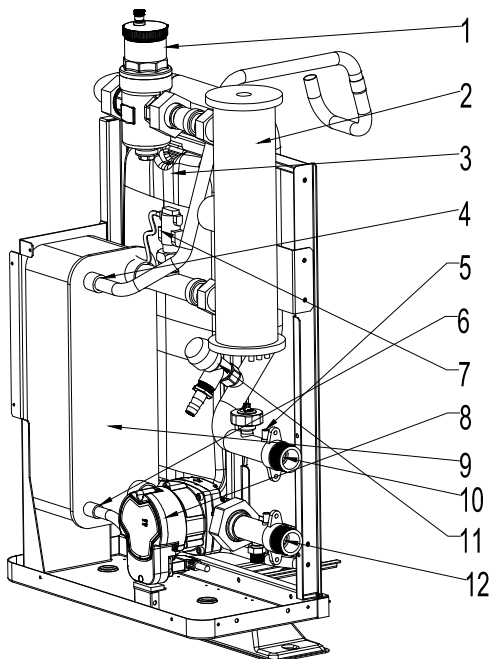

Figure 1-6: Hydraulic module - 6.5kW

1.11.4 HPR2901120 & HPR2901160

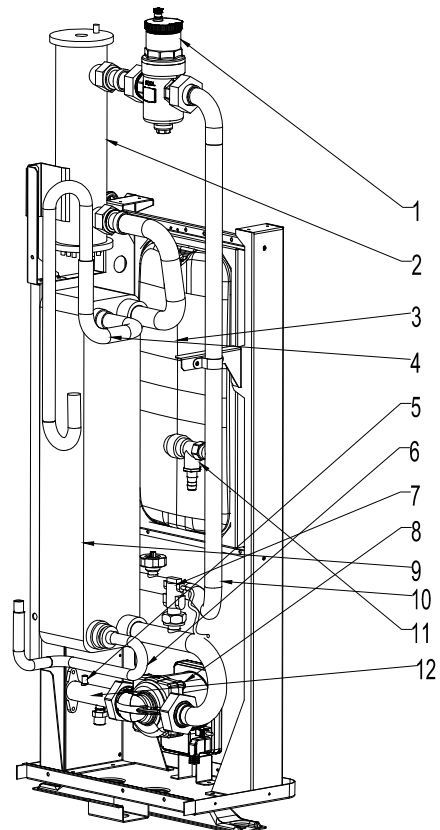

Figure 1-8: Hydraulic module - 12kW & 16kW

Table 1-5: Key items for Figures 1-5 to 1-8

Code	Assembly unit	Explanation
1	Automatic air purge valve	Remaining air in the water circuit will be automatically removed from the water circuit
2	Immersion	Provides additional heating capacity due to very low outdoor temperatures and also protects external water pipes from freezing
3	N/A	N/A
4	Refrigerant gas pipe	Conducts refrigerant in liquid state
5	Temperature sensor	Temperature sensor determine the water and refrigerant temperature at various points in the water circuit
6	Refrigerant liquid pipe	Conducts refrigerant in liquid state
7	Flow switch	Detects water flow rate to protect compressor and water pump in the event of insufficient water flow
8	Pump	Circulates water in the water circuit
9	Plate heat exchanger	Transfer heat from the refrigerant to the water
10	Water return inlet	Water return from the property to the heat pump
11	Pressure relief valve	Prevent excessive water pressure by opening at 3 bar and discharging water from the water circuit.
12	Water flow outlet	Water flow from the heat pump to the property

! NOTE !

This appliance is designed exclusively for domestic or semi-domestic purposes. This means that even users without prior instruction should be able to operate the appliance safely.

2 TECHNICAL DATA

2.1 HEAT PUMP TECHNICAL DATA

Table 2-1: Technical Data

	Unit	Model				
		HPR290i40	HPR290i65	HPR290i90	HPR290i120	HPR290i160
Heating capacity (BS EN 14511 - air: 7°C / water: 35°C)	kW	4.09	7.62	9.38	12.18	16.16
COP (BS EN 14511 - air: 7°C / water 35°C)	-	4.99	4.95	4.93	4.81	4.72
Heating capacity (BS EN 14511 - air: -5°C / water: 55°C)	kW	4.10	6.76	9.21	12.00	15.57
COP (BS EN 14511 - air: -5°C / water 55°C)	-	2.48	2.27	2.31	2.25	1.90
SCOP average climate conditions (BS EN 14825 at 35°C)	-	4.67	4.88	4.57	4.68	4.50
Heating capacity (BS EN 14511 - air: 7°C / water: 55°C)	kW	4.36	7.23	9.30	12.21	16.33
COP (BS EN 14511 - air: 7°C / water 55°C)	-	3.19	3.00	3.11	3.22	2.87
SCOP average climate conditions (BS EN 14825 at 55°C)	-	3.48	3.53	3.63	3.70	3.29
ErP rating (low temperature: 35°C / 55°C) - heating	-	A+++ / A++				
Minimum Modulation	kW	1.25	2.40	2.51	3.20	4.63
Turn-down (from Nominal Output)	%	30.49	35.50	28.34	26.67	29.74
Maximum Flow rate required	litres/min	11.77	19.41	26.44	34.45	44.70
Rated Air Flow	m³/h	2300	2650	3350	4050	4050
Total Fan Input Power	W	100	170	170	200	200
Refrigerant system pressure (minimum/maximum)	MPa	0.3 to 3.5				
Water Pressure drop	kPa	25	39	38	38	40
Refrigerant	-	R290				
GWP	-	3				
Mass of R290 Refrigerant	kg	0.61	0.83	1.00	1.20	1.65
Equivalent CO ₂	ton	0.002	0.002	0.003	0.004	0.005
Circulating pump	m head	9	9	9	9	9
Water connections	BSPF	1"	1"	1"	1"	1"
Maximum inlet water pressure	bar	3				
Maximum inlet water temperature	°C	75				
Waterside heat Exchanger	-	Plate heat exchanger				
Operating temperature range (space heating)	°C	-25 to 35				
Operating temperature range (DHW)	°C	-25 to 43				
Water pressure (system)	MPa	0.1 to 0.3				
Water drain	-	Hose nipple				
Pressure relief valve water circuit	bar	3				
Water flow rate	litres/min	10 to 20	10 to 35	10 to 35	10 to 50	10 to 50
Operating flow temperature (space heating)	°C	25 to 75				
Operating flow temperature (DHW)	°C	20 to 70				
Sound power level (BS EN12102-1)	dB	48.00	51.70	53.60	52.00	52.90
Sound Pressure level (Q=2)	1m db	40.02	43.71	45.61	44.01	44.91
Sound Pressure level (Q=2)	3m db	30.47	34.17	36.07	34.47	35.37
QuietMark	-	Yes	Yes	Yes	Yes	Yes
Height	mm	803	854	854	1365	1365
Width	mm	1155	1223	1223	1155	1155
Depth	mm	422	461	461	425	425
Weight (empty)	kg	99	115	131	153	180
Weight (full)	kg	102	117	133	157	184
Water content	litres	1.60	1.90	2.10	4.0	4.0
Heat pump casing volume	m³	0.391	0.482	0.482	0.706	0.706

2.2 HEAT PUMP DIMENSIONS

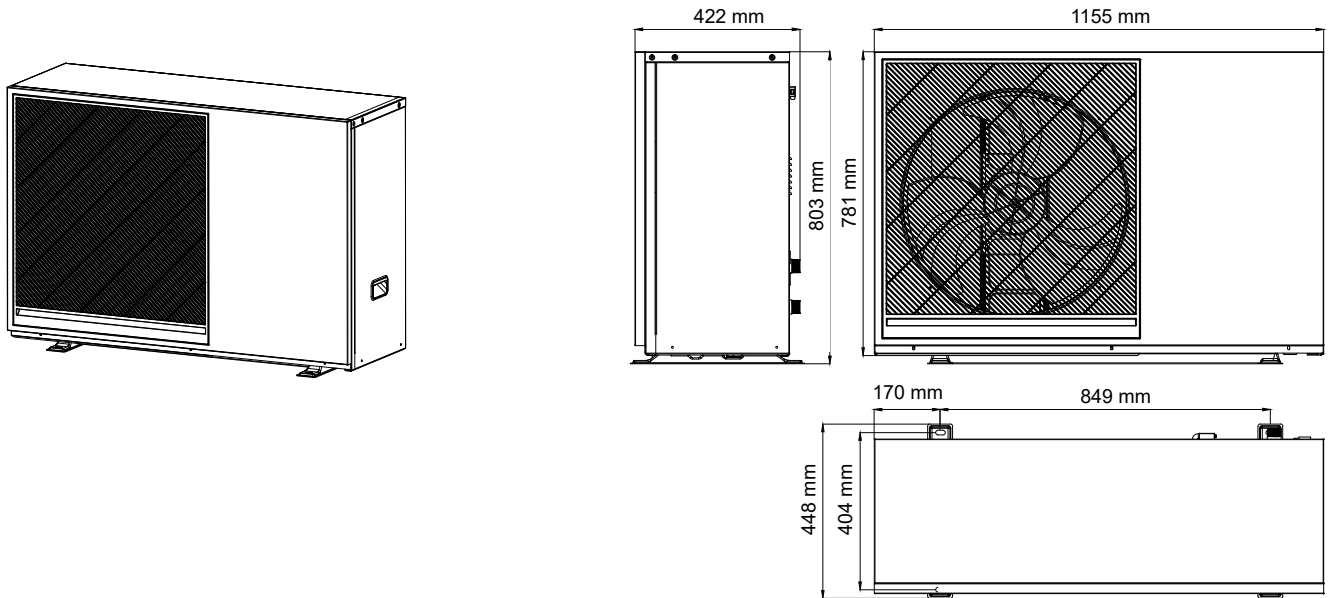

Figure 2-1: HPR290i40 heat pump dimensions

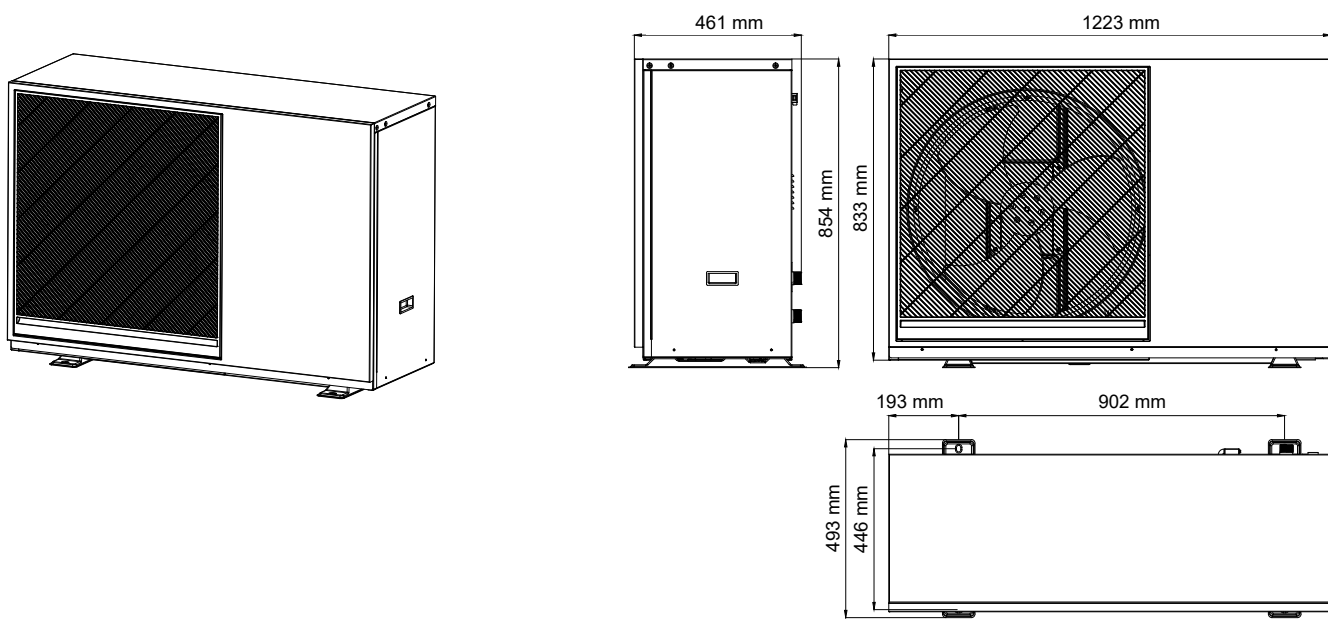

Figure 2-2: HPR290i65 & HPR290i90 heat pump dimensions

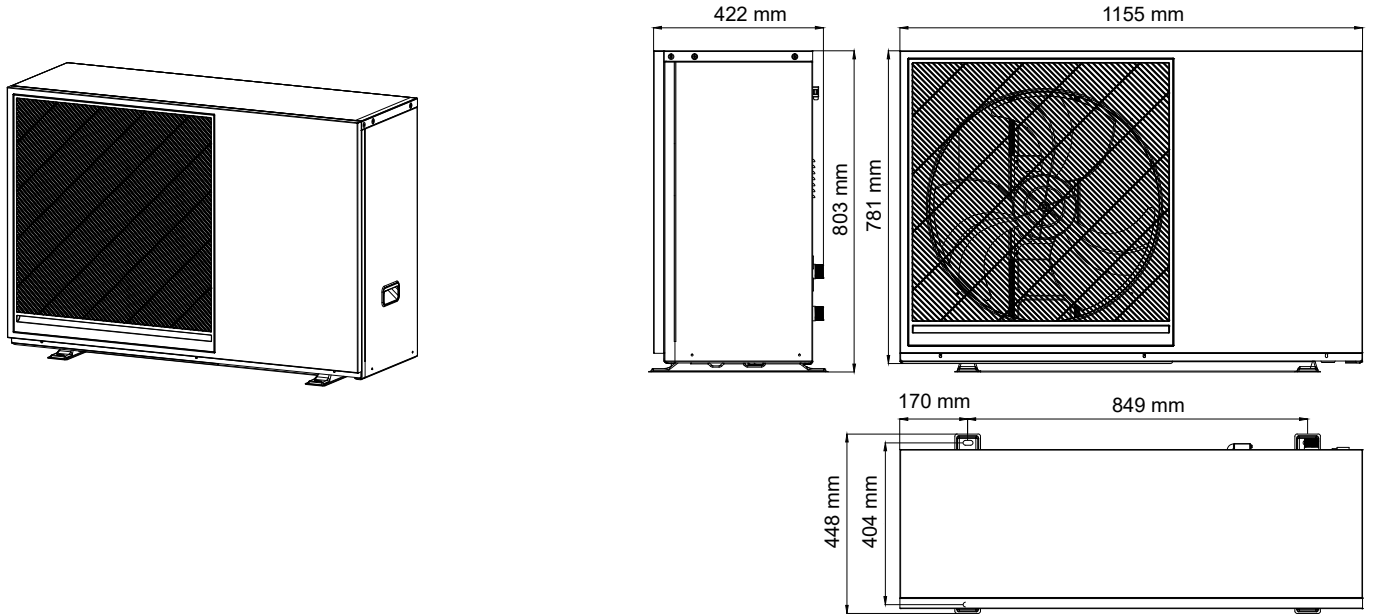

Figure 2-3: HPR290i120 & HPR290i160 heat pump dimensions

3 INSTALLATION INFORMATION

3.1 BEFORE INSTALLATION

Installation and maintenance access

1. Remove highlighted screws
2. Pull down firmly on handle shown below

4kW, 6.5kW & 9kW

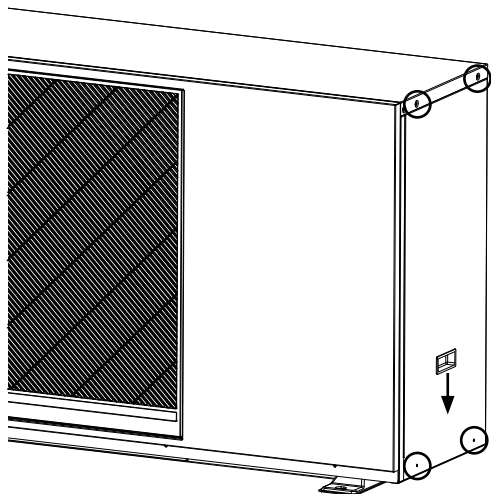

12kW & 16kW

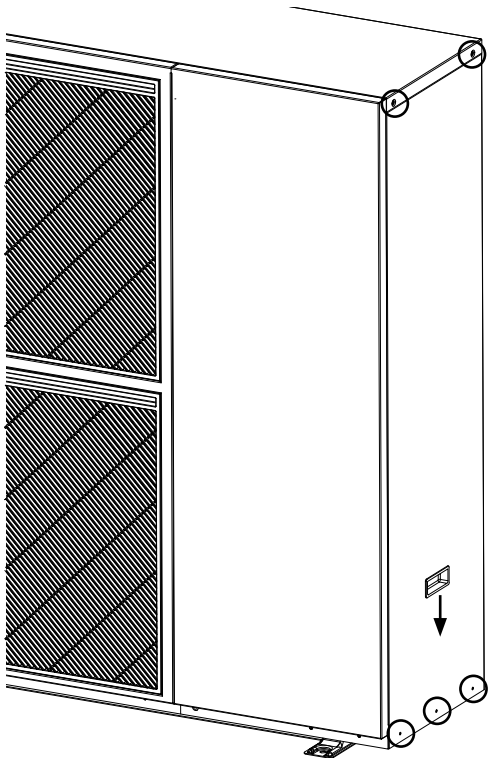

! NOTE !

Read and follow all instructions before installation of the unit

! NOTE !

Please reference unit weight on supplied data labels or boxes before moving

! CAUTION !

Due to the flammable nature of R290 ensure adequate ventilation when installing heat pump

! CAUTION !

Use appropriate measures to move heat pump into position

Before installation be sure to confirm the model name and the serial number of the unit.

When handling the unit:

Due to relatively large dimensions and heavy weight, the unit should only be handled using **lifting tools with slings**. The slings can be fitted into foreseen sleeves at the base frame that are made specifically for this purpose. Refer to Figure 3-1.

! CAUTION !
 To avoid injury, do not touch the air inlet or aluminium fins of the unit.

! CAUTION !
 Do not grip the unit by the fan grilles when lifting to avoid damage.

! CAUTION !
 The unit is top heavy! Keep the unit upright to prevent it from falling over during handling.

! NOTE !
 When units are delivered, check whether any damage occurred during shipment. If there is damage to the surface or the outside of the unit, submit a written report to the shipping company.

! NOTE !
 Check that the model, specifications and quantity of units have been delivered.

! NOTE !
 Check that all accessories ordered have been included. Retain the owner's manual for future reference.

! NOTE !
 Do not remove any packaging before hoisting. If unit is not packaged or if the packaging is damaged, use suitable board or packing material to protect the unit.

! NOTE !
 Hoist one unit at a time using two ropes or suitable lifting straps to ensure stability.

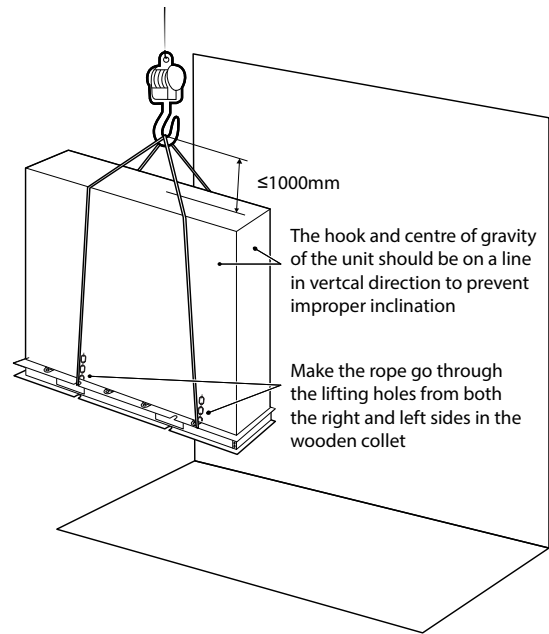

Figure 3-1: Lifting the unit

Centre of gravity of the R290

The position of the centre of gravity for different units can be seen in Table 3-1 & Figures 3-2, 3-3 & 3-4.

Table 3-1: The centre of gravity location - dimensions (mm)

Model	A	B	C
Aerona R290 4 kW	450	400	190
Aerona R290 6.5 & 9 kW	500	440	200
Aerona R290 12 & 16 kW	700	400	230

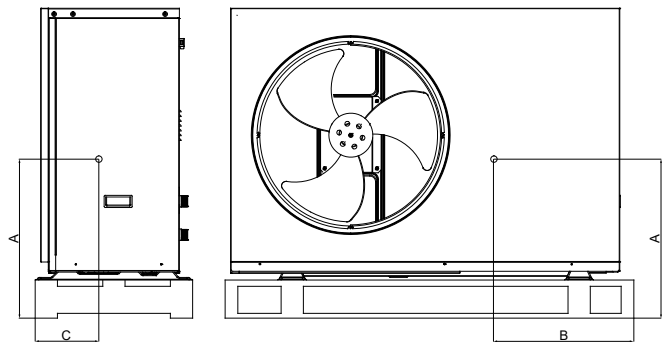

Figure 3-2: Centre of gravity for 4kW output

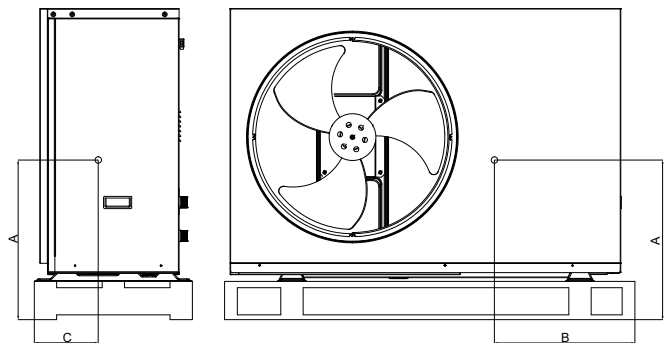

Figure 3-3: Centre of gravity for 6.5kW & 9kW output

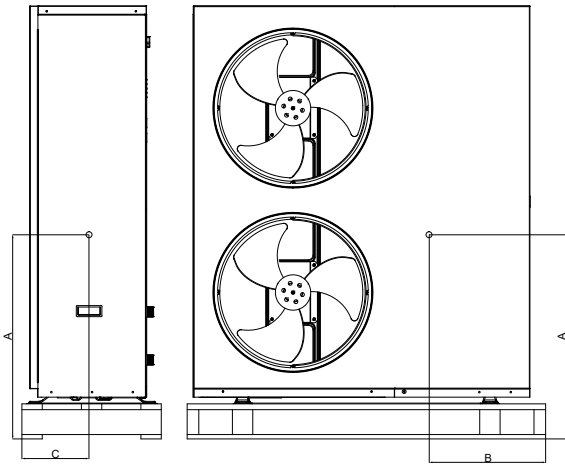

Figure 3-4: Centre of gravity for 12kW & 16 kW output

3.2 INTRODUCTION

For the heat pump to operate satisfactorily, install it as outlined in this installation manual.

- The Grant R290 heat pump should only be installed by a competent person.
- Before installing the heat pump, please read the following installation information carefully and install the heat pump as instructed.
- Be sure to follow the safety notices given.
- After completing the installation, check the product operates correctly. Then, explain to the user about the operation and maintenance requirements as shown in this manual.
- Be sure to install the heat pump in a suitable location that can support the heat pump when filled. Installation in an unsuitable location may cause injury to persons and damage to the heat pump.
- Do not install in a position where there is any possibility of flammable gas leakage such as from LPG cylinder around the heat pump. Leaked flammable gas around the heat pump may cause a fire.
- After completing the installation, check for refrigerant leakage.
- Never directly touch any leaking refrigerant as it could cause severe frostbite.
- Do not touch the refrigerant pipes during and immediately after operation as the refrigerant pipes may be hot or cold, depending on the condition of the refrigerant flowing through the refrigerant piping, compressor and other refrigerant cycle parts. Burns or frostbite are possible if you touch the refrigerant pipes. To avoid injury, give the pipes time to return to normal temperature or, if you must touch them, be sure to wear protective gloves.
- Connect the heat pump with the flexible hoses and valves supplied, as described in this installation manual.
- Do not use an extension cable.
- Do not run on a generator
- Do not turn on the power until all installation work is complete.
- Only use correct Grant parts and accessories to avoid accidents such as electric shock, fire and leakage of water.
- Never touch electrical components immediately after the power supply has been turned off as electrical shock may occur. After turning off the power, always wait five or more minutes before touching electrical components.
- Be sure to connect the power supply cable correctly to the terminal block as overheating can cause a fire.
- Ensure all covers are fitted following installation to avoid the risk of electric shock from electrical terminals or components.
- Always connect the earth wire to the heat pump.
- Install a correctly rated circuit breaker.
- After installation, the heat pump and heating system must be commissioned. Hand over all documentation to the end-user and explain the operating functions and maintenance according to these instructions.

3.2.1 HEATING SYSTEM DESIGN CRITERIA

Before continuing with the installation of the R290 heat pump, please spend a few minutes confirming the suitability of the heat pump to your system. Failure to do so may result in poor performance and wasted time:

- Has a room-by-room heat loss calculation been carried out?
- Has cavity wall insulation been installed?
- Has loft insulation of 400mm been fitted?
- If monovalent, what is the total heating capacity?
- Are the existing controls being upgraded?
- Will a volumiser be used?
- If yes, what is the capacity of the volumiser?
- Have all system pipes been correctly sized and insulated?

3.2.2 SYSTEM DESIGN CRITERIA

A typical condensing oil or gas fired boiler operates with a flow of 70°C and a return of 50°C, i.e. with a ΔT of 20°C. The Grant Aerona R290 heat pump is designed to operate with a flow of between 24°C and 55°C (in space heating mode) or 55°C (in domestic hot water) with a ΔT of 5K.

The design of any system in ROI or NI is typically based on the following parameters:

1. The outside design air temperature - This can fall to -3°C or lower.
2. The internal design air temperature - This can be between 18-22°C depending on the room concerned.
3. The heat pump flow temperature - This operates at lower water temperatures than an oil or gas fired appliance.

Designing a new system for use with a heat pump is straight forward, assuming the insulation and air tightness properties of the dwelling meets or exceed current Building Regulations and the lower flow/return temperatures are taken into account in the selection of the type and size of the heat emitters used.

While underfloor heating is the preferred heat emitter, a combination of underfloor heating and radiators, or radiators only, works also. It is necessary, however, to calculate the size of radiator required accurately – if this is not done, the house will fail to reach the target temperature and will be costly to rectify after the installation is complete. Its also vital the pipe diameter is correct.

When tested to BS EN 14511, the heat output for a heat pump is declared at the test conditions of 7°C outside air temperature and 35°C or 55°C water flow temperature.

The nominal output for the Aerona R290 heat pump range is based on -5°C outside air temperature and 55°C water flow temperature.

At all other values of outside air temperature and water flow temperature the actual heat pump output will vary, e.g. the heat output will:

- Decrease with lower outside air temperatures and increase with higher outside air temperatures at any given water flow temperature, and
- Decrease with higher water flow temperatures and increase with lower water flow temperatures at any given outside air temperature.

Provided that the heat pump is sized correctly for the system, the internal backup heater will only compensate for any short fall in meeting the heat load for the property below the minimum design air temperatures.

3.2.3 HEAT EMITTER SIZING

For guidance on sizing heat emitters, e.g. radiators and/or underfloor heating, refer to the Domestic Heating Design Guide, the Underfloor Heating Design Guide and SR50-4 for the Republic of Ireland.

3.3 REGULATIONS

Installation of a Grant Aerona R290 heat pump must be in accordance with the following recommendations:

- National Building Regulations, e.g. Approved Documents L & G Documents and SR50-4.
- Local Bylaws (Check with the Local Authority for the area).
- Water Supply (Water Fittings) Regulations 1999.
- MCS Installers Standards (when required, e.g. for installations for the Boiler Upgrade Scheme).
- MIS 3005 - I. The Heat Pump Standard - Installation.
- MIS 3005 - D. The heat pump Standard - Design.
- MCS 020. MCS Planning Standard.

The installation should also be in accordance with the latest edition of the following standards and codes of practice:

- BS 7671 and Amendments. Requirements for Electrical Installations. IET Wiring Regulations, for ROI, IS-10101 NREI edition 5 National Rules for Electrical Installations.
- BS EN 12831. Energy performance of buildings. Method for calculation of the design heat load. Space heating load.
- BS 7593. Code of practice for the preparation, commissioning and maintenance of domestic central heating and cooling water systems.

! WARNING !

There is flammable refrigerant in the unit and it should be installed in a well-ventilated site. If the unit is installed in indoor spaces, an additional refrigerant detection device and ventilation equipment must be added in accordance with the standard BS EN 378.

! WARNING !

Be sure to adopt adequate measures to prevent the unit from being used as a shelter by small animals.

Small animals making contact with electrical parts can cause malfunction, smoke or fire. Please instruct the user to keep the area around the unit clean and unobstructed.

3.4 HEAT PUMP LOCATION

When assessing a location to install the Grant Aerona R290 heat pump, many factors will need to be considered. Discuss with the homeowner to choose the most suitable and practical position

- Consider a place where the noise and the air discharged will not affect neighbours.
Take opening windows and doors into account. It is not essential for the heat pump to be positioned next to a wall of the house. Behind an out-building may be more suitable so discuss the options with the homeowner. Refer to Section 2 for heat pump sound levels.
- Install the heat pump in a place where it will be free from adverse weather conditions as much as possible.
- Consider a position protected from the wind. Do not install the heat pump where strong wind blows directly onto the heat pump or where it is very dusty
- When installing the heat pump where it may be exposed to strong wind, brace it securely.
- For installation of the unit in a place where the wind direction can be foreseen, set the heat pump outlet side at a right angle to the direction of the wind. Refer to Figure 3-5.

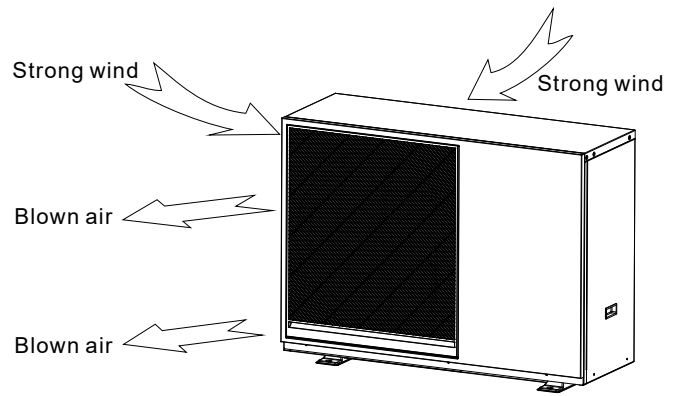

Figure 3-5: Wind installation

- Consider an area that provides the minimum space required for airflow, servicing and maintenance. Refer to section 3.6.9 for clearances.
- Ensure that sufficient precautions are taken in case of refrigerant leakage. Refer to Section 3.6 for details of protective zones.
- Do not install the heat pump where people pass frequently.
- Take preventive measures so that young children cannot reach the unit.
- Do not install the unit in places often used as a work space.
- The surfaces of the floor (or the wall for wall mounted heat pumps - refer to section 3.6.12) must be solid enough to support the weight of the heat pump and minimise the transmission of noise and vibration. Refer to section 2.1 for the weights of the units.
- Install the heat pump in a place where it will be level or not inclined more than 5°.
- Install the heat pump in a place where the flow condensate water produced during operation will not be obstructed.
- The equipment is not intended for use in a potentially explosive atmosphere.
- Places where water leaking from the unit cannot cause damage to the location, e.g. in case of a blocked drain pipe.
- Places when rain can be avoided as much as possible.
- The Grant Aerona R290 heat pumps are usually suitable for installation in coastal areas without any special treatment, but we do recommend the evaporator is sprayed with ACF50 and this must be repeated on each service.
- Do not discharge a tumble dryer behind the heat pump.

In case of any construction work, e.g. grinding, sanding, cutting, etc, where a lot of dust is created, the unit should be switched off and covered until the work is finished.

- Do not place any object or equipment on the top of the unit.
- Do not climb, sit or stand on the top of the unit.

Do not install the unit in the following places:

- Where there is mist of mineral oil, oil spray or vapours. Plastic parts may deteriorate and cause them to come loose or water to leak.
- Where corrosive gases (such as sulphurous acid gas or chlorine gas[swimming pools]) are produced. Where corrosion of copper pipes or soldered parts may cause refrigerant to leak.
- Where there is machinery which emits electromagnetic waves. Electromagnetic waves can disturb the control system and cause equipment malfunction.
- Where flammable gases may leak, where carbon fibre or ignitable dust is suspended in the air or where volatile flammables such as paint thinner or gasoline are handled. These types of gases might cause a fire.
- In vehicles or vessels.
- Where acidic or alkaline vapours are present.

3.5 PREPARATION FOR INSTALLATION

! NOTE !

Grant R290 heat pumps should be stored and transported in an upright position. If not, then the heat pump **MUST** be positioned in an upright position for at least four hours before being operated.

3.5.1 R290 REFRIGERANT

The Grant Aerona R290 heat pump contains R290 refrigerant gas. The density of this gas is greater than that of air, so in the event of leakage it tends to disperse and stratify, accumulating in niches, depressions in the ground or underground regions.

It is mandatory to comply with the protective zones given in this manual, when installing the units. The protective zones have been designed in accordance with EN 60079-10-1, estimating an appropriate refrigerant loss in order to guarantee the safety of the units in the installation area.

The protective zone is defined as an area around the heat pump in which, in the event of a leakage of refrigerant gas, a flammable atmosphere could be formed for a short time, within which it is necessary to implement all the precautions described in the manual.

In the absence of specific standards or regulations, when using the unit in an industrial or working environment, it is advisable to carry out the classification of places with explosion hazards considering the ATEX Directive 1999/92 (Directive 89/391).

No sources of ignition should be present in the protective zone, including:

- Flammable gases and sprays, self-igniting powders;
- Electrical equipment that is not suitable for use in potentially explosive areas (zone 2 according to Directive 89/391);
- Naked flames, heated surfaces (maximum surfaces temperature of 360°C and processing by heat; smoking is prohibited, even for electronic cigarettes).
- Sparks, electrostatic charges, direct and indirect lightning effects, eddy currents and cathodic protection.
- Ignition sources due to remote processes (ionising and non-ionising radiation).
- Permanent electrical sources (switches, lamps, etc.) or other possible triggers.

In addition, protective zones must NOT:

- Include potentially dangerous areas or features such as wells, manholes, openings to the sewage system and other openings to underground places and premises (e.g. garages), river drains, power lines, flammable deposits, electrical installations, etc.
- Include doors, windows or glass panes, to prevent the possible return of the gas inside the building.
- Extend towards neighbouring residential properties, parking areas, public access sites, roads or railways.

Beyond the protective zone in the event of a refrigerant leak, the concentration of refrigerant gas in the air is typically below the critical levels for the formation of flammable or hazardous atmospheres. You must take reasonable care to:

- Prevent accumulation and stagnation in underground spaces, drains, manholes, cellars, etc.
- not place close to building vents.
- to not use naked flames and other direct heat sources.

Ensure to comply with national and local regulations for the installation of machinery (as applicable) in order to prevent the formation of fire hazards and to prevent gases from seeping underground into openings to the ground or floors below. No structural modifications may be made in the protective zone that would alter their extent or change the behaviour of the air-refrigerant mixture.

It is also strictly forbidden to tamper with, alter, remove or compromise, even partially, the functionality of the devices, guards and warnings provided for the safety of property and persons.

! WARNING !

Do not pierce the evaporator or refrigerant circuit or expose the heat pump to fire.

3.6 PROTECTIVE ZONES

3.6.1 GROUND INSTALLATIONS

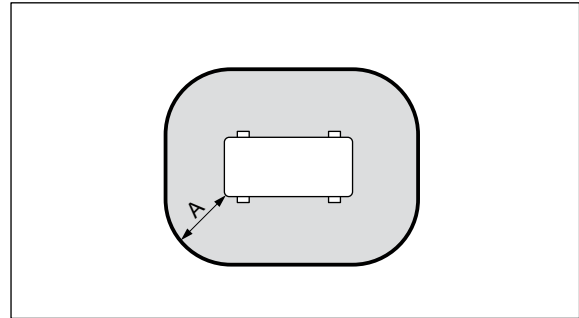

Figure 3-6: Ground installation

Table 3-2: Ground installation protective zone

Dimension	Distance (mm)
A	1000

3.6.2 GROUND INSTALLATIONS IN FRONT OF A BUILDING WALL

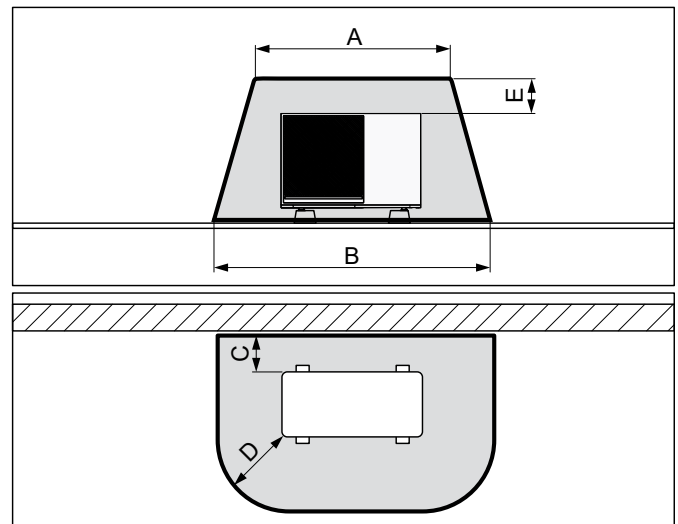

Figure 3-7: Ground installation in front of a building

Table 3-3: Ground installation in front of a building protective zone

Dimension	Distance (mm)
A	2100
B	3155 (for 4kW, 12kW & 16kW) 3223 (for 6.5kW & 9kW)
C	250
D	1000
E	500

3.6.3 GROUND INSTALLATION IN A BUILDING CORNER

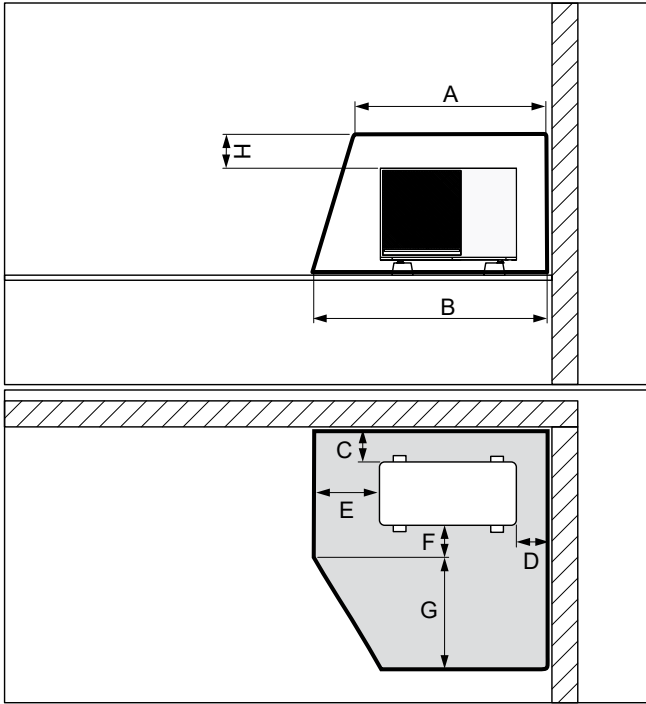

Figure 3-8: Ground installation in a corner

Table 3-4: Ground installation in a corner protective zone

Item	Distance (mm)
A	2100
B	2655 (for 4kW, 12kW & 16kW) 2723 (for 6.5kW & 9kW)
C	250
D	500
E	1000
F	500
G	1800
H	500

3.6.4 WALL INSTALLATION IN A LOW POSITION

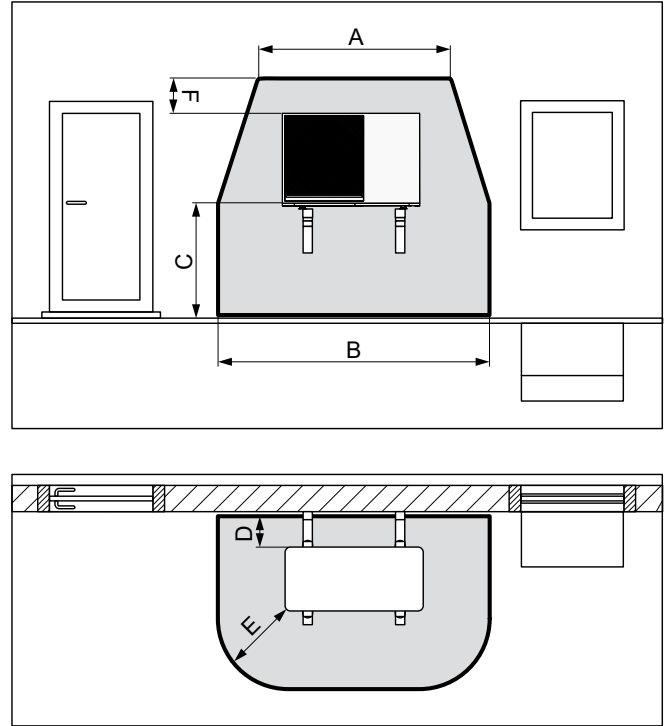

Figure 3-9: Wall installation in a low position

Table 3-5: Wall installation in a low position protective zone

Dimension	Distance (mm)
A	2100
B	3155 (for 4kW, 12kW & 16kW) 3223 (for 6.5kW & 9kW)
C	<1000
D	200
E	1000
F	500

3.6.5 WALL INSTALLATION IN A RAISED POSITION

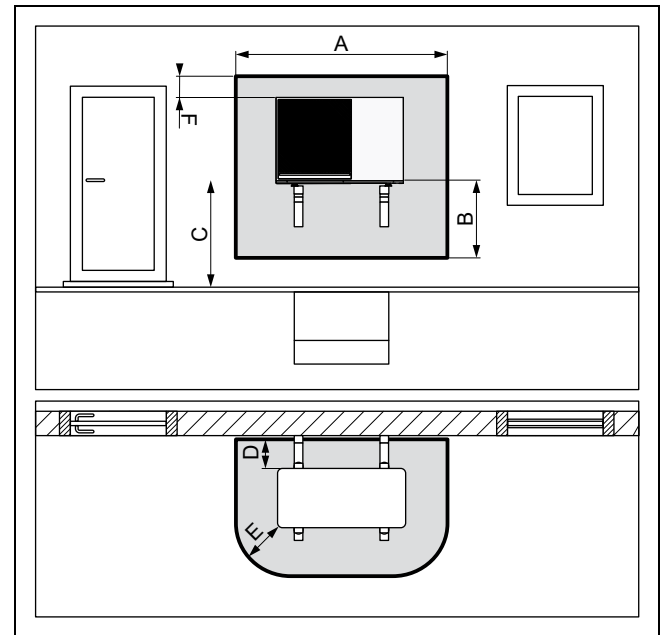

Figure 3-10: Raised wall installation

Table 3-6: Raised wall installation protective zone

Dimension	Distance (mm)
A	2100
B	1000
C	>1000
D	200
E	500
F	500

3.6.6 RAISED WALL INSTALLATION IN A LEFT-HAND CORNER

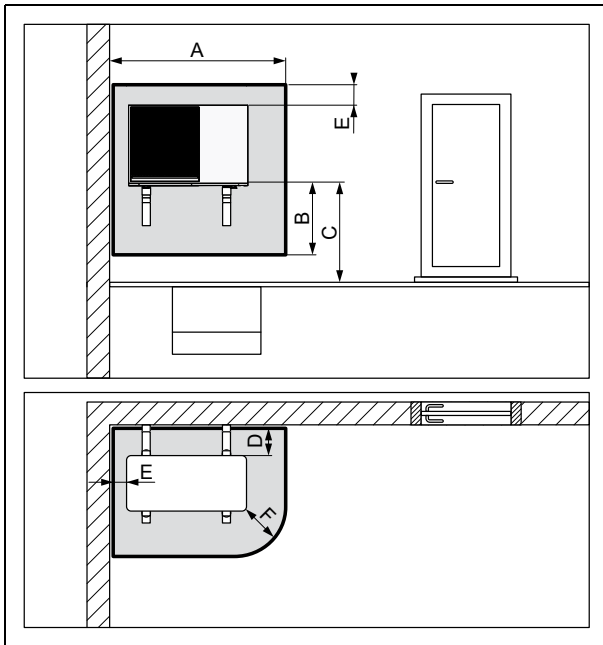

Figure 3-11: Raised Wall installation in a left-hand corner

Table 3-7: Raised wall installation in a left corner protective zone

Dimension	Distance (mm)
A	1700
B	1000
C	>1000
D	200
E	500

3.6.7 RAISED WALL INSTALLATION IN A RIGHT-HAND CORNER

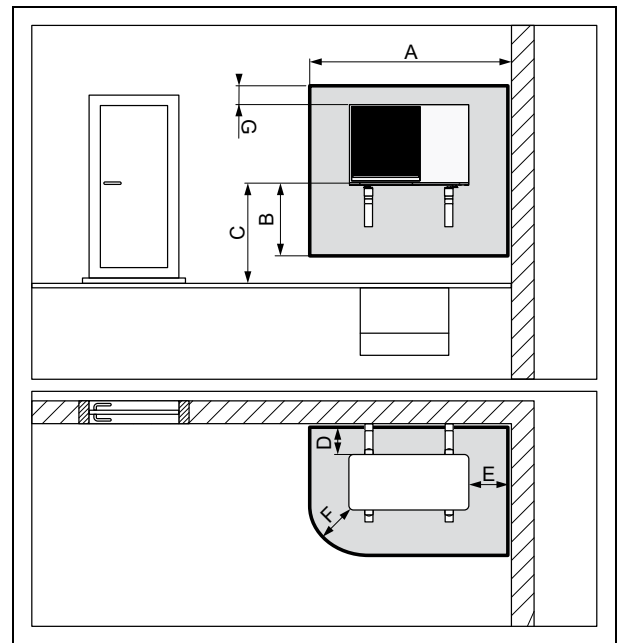

Figure 3-12: Raised Wall installation in a right-hand corner

Table 3-8: Raised wall installation in a right corner protective zone

Dimension	Distance (mm)
A	2100
B	1000
C	>1000
D	200
E	500
F	500
G	500

3.6.8 BASE

Unless the heat pump is to be wall mounted (refer to Section 3.6.12 for further information), it should be installed on a firm flat level surface capable of supporting the weight of the heat pump and minimising the transmission of noise and vibration, for example:

- A flat trowelled concrete base approximately 150mm thick.
- Paving slabs on compacted hard core of a sufficient depth for the ground condition.
- The surface should extend at least 150mm beyond the heat pump on three sides

Alternatively, two separate smaller concrete bases can be used, each one being sized and positioned to align with the anti-vibration mounts of the heat pump model being installed.

In all the above cases a trench can be dug around the base(s) and filled with chippings or gravel to provide a means of condensate disposal. Refer to Section 3.6.10.

If the surface of the base(s) is level with or above the damp course for the building, leave a gap of approximately 150mm between the edge of the base and the wall of the house to avoid bridging the DPC.

The heat pump should NOT be installed on loose or uneven surfaces such as grass, soil, shingle or gravel.

The heat pump must be raised up from the surface of the base by approximately 100mm on suitable anti-vibration mounts.

To ensure correct drainage of water from the heat pump base tray, the heat pump must be level across both the width and depth when installed.

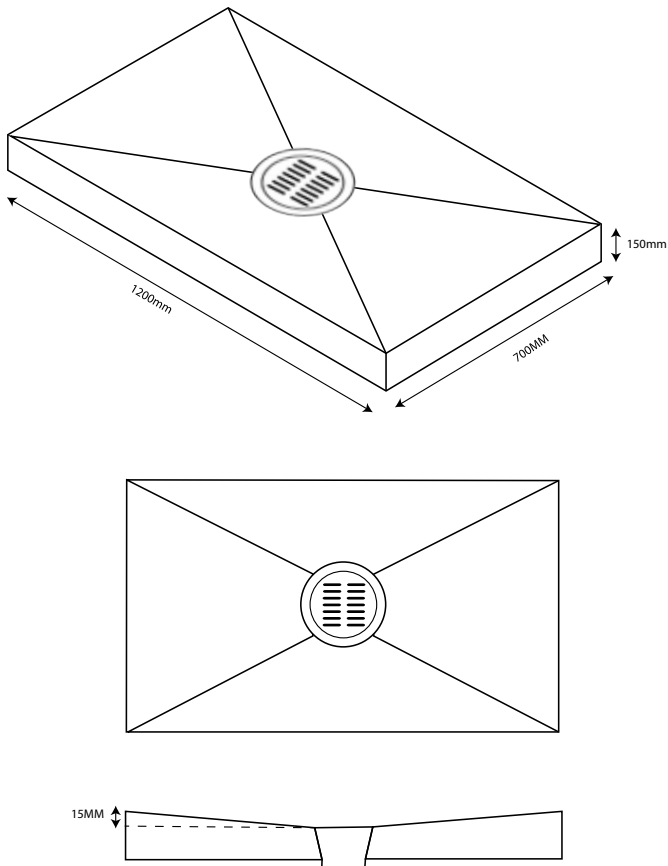

Figure 3-13: Recommended heat pump base

3.6.9 CLEARANCES

The following **minimum** clearances must be used to enable the product to be easily commissioned, serviced and maintained and allow adequate air flow in and out of the heat pump.

For ground installation clearances, refer to Table 3-9 and Figure 3-14.

For wall mounted installation clearances, refer to Table 3-10 and Figure 3-15.

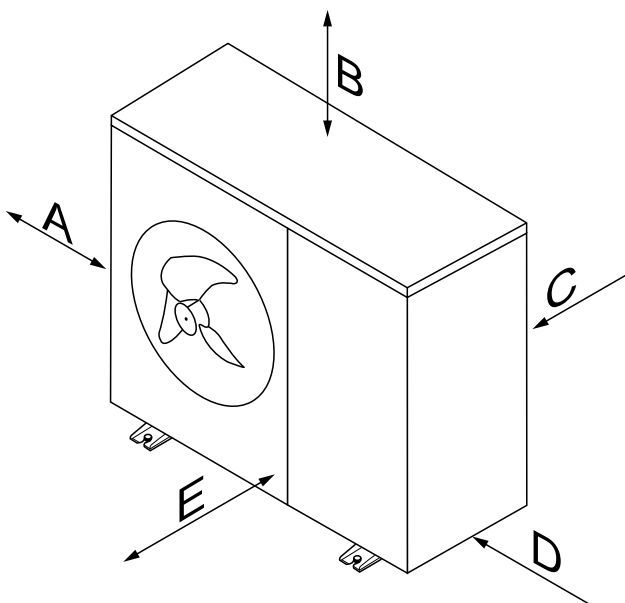

Figure 3-14: Ground installation clearances

! WARNING !

Failure to adhere to these clearances may result in non-commissioning of the heat pump and may invalidate the warranty

Table 3-9: Ground installation clearances

Item	Minimum clearance required (mm)
A	100
B	1000
C	300
D	500
E	1000

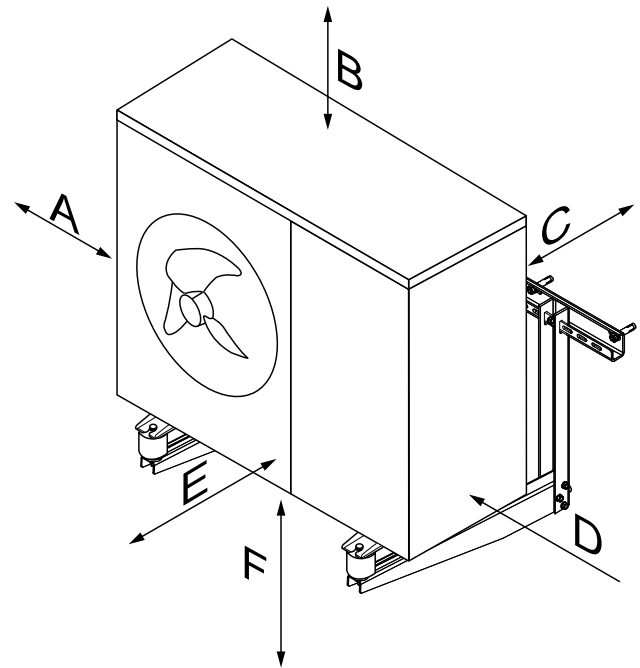

Figure 3-15: Wall mounted installation clearances

Table 3-10: Wall mounted installation clearances

Aspect	Minimum clearance required (mm)
A	100
B	1000
C	250
D	500
E	1000
F	300

- Ensure there is sufficient clearance around the heat pump to carry out the installation. Ideally set the outlet side of the heat pump at a right angle to the direction of the prevailing wind.
- Prepare a water drainage channel around the foundation to drain waste water from around the unit.

3.6.10 CONDENSE DISPOSAL

The underside of the heat pump has three condensate drain holes (Refer to Figures 3-16 to 3-18). These allow any condensate to drain from the heat pump.

Provision must be made to safely dispose of this condensate.

The supplied condensate drain elbows can be inserted into the drain holes and flexible pipes fitted to direct condensate to safe drainage spots.

For example, use 40 mm waste pipe to form a condensate disposal system into which the condensate flows from the flexible pipes from the drain holes in the bottom of the heat pump casing running to a suitable gully or soakaway.

Another option would be to dig a trench filled with chippings or gravel around the base on which the heat pump is located. This will allow the condensate flowing from the drain holes in the base of the heat pump to safely disperse and not form a pool around the heat pump that will freeze in winter months.

As well as the condensate drain holes, there are also overflow holes located in the base tray of the unit. If the drain holes cannot meet the drainage requirements, when the water level reaches a certain height, it will automatically use the overflow holes to drain. Refer to Figures 3-17 to 3-19.

! WARNING !

It is essential that the condensate is able to drain away and not allowed to run onto any adjacent paths or driveways where, in winter, this will result in icing and a potential hazard for anyone walking near the heat pump. The top of the concrete base must be either level with, or above, the surrounding ground level.

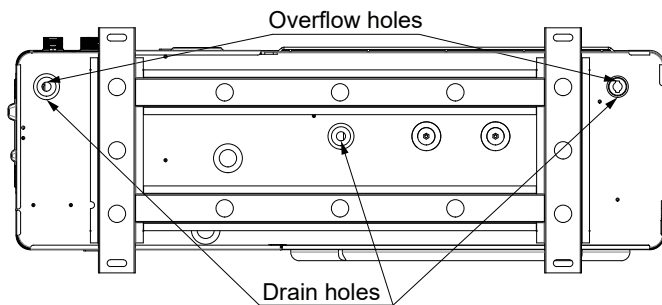

Figure 3-16: Drain and overflow holes - 4kW

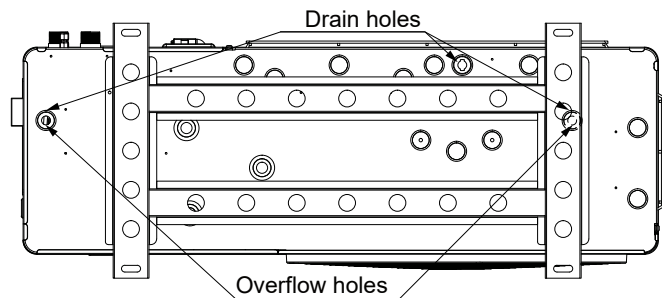

Figure 3-17: Drain and overflow holes - 6.5kW & 9kW

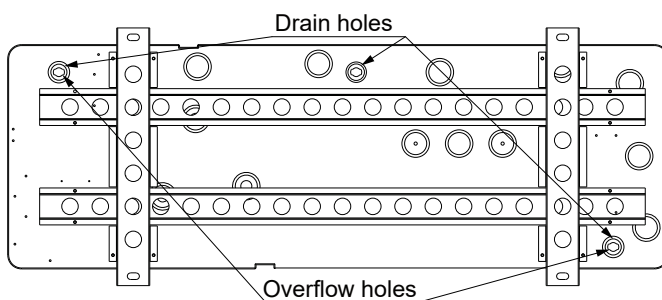

Figure 3-18: Drain and overflow holes - 12kW & 16kW

3.6.11 VIBRATION

To avoid any vibration from the heat pump causing a nuisance, install the heat pump on anti-vibration mounts, available from Grant Engineering (product code: HPIDFOOT/KIT2). These anti-vibration mounts are also supplied in the Installation packs. Refer to Section 1.9.

Securely fix the heat pump to these anti-vibration mounts using the mounting feet at the bottom of the heat pump.

These anti-vibration mounts are not suitable for units that are to be wall mounted.

3.6.12 WALL MOUNTED INSTALLATIONS

All five sizes of Grant Aerona R290 heat pump can be wall mounted at a safe height, with the top of the unit no more than 2m above ground level, where no specialist access equipment (such as mobile tower or scaffolding) is required to provide a safe working place to carry out servicing or repairs.

Grant can supply a suitable mounting bracket (product code: HPCBR2) for all Grant Aerona R290 models with a maximum Safe Working Load of 250kg. Refer to section 2 for details on weights.

If any other method of wall mounting is used, it is the responsibility of the installer to select a suitable mounting method (Refer to Section 2 for weights). Grant cannot take any responsibility for any mounting brackets other than the one supplied.

When assembling the mounting brackets, please follow the manufacturers installation instructions

In all cases, care should be taken to determine that the condition of the wall is suitable to carry the load imposed by the heat pump and ensure that the mounting bracket is firmly secured to the wall, using suitable fixings for the wall construction concerned.

If installed in a position where specialist access equipment, such as a mobile tower or scaffolding, is required to provide a safe place of work to carry out servicing or repairs, then the cost and provision of this equipment is the responsibility of the property owner/user irrespective of whether the heat pump is deemed to be at fault or not.

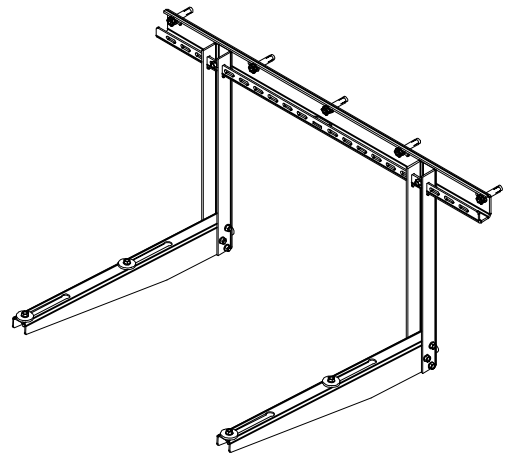

Figure 3-19: Wall mounting brackets

3.7 INSTALLING THE HEAT PUMP

3.7.1 INSULATION

It is essential that the complete water circuit, including all internal and external water pipework, valves, and pipework passing through external walls, must be insulated to reduce heat loss and a reduction in heating output and heat pump efficiency, and also to prevent freezing of external pipework during winter months.

The insulation material should have a B1 fire resistance rating and comply with all applicable legislation.

Any external insulation should be UV resistant and all joints should be sealed to prevent water ingress.

The level of insulation used should comply with the requirements of the Building Regulations Approved Document L and Part L 2019.

The thickness of the pipe insulation will depend on the pipe diameter and the thermal conductivity of the insulation. For more details, refer to the Domestic Heat Design Guide.

Example:

For a 28mm diameter pipe, and insulation with a thermal conductivity of 0.04W/mK, the thickness of the insulation material should be at least 25mm.

! WARNING !

Safely dispose of packing materials such as nails and other metal or wood parts that could cause injuries.

3.7.2 CONNECTING THE HEATING SYSTEM TO THE HEAT PUMP

Water connections must be made in accordance with diagrams in this manual and the labels on the heat pump.

- Be careful not to deform the heat pump pipework by using excessive force when connecting.
- Pipework should be flushed before connecting the heat pump.
- Cover the pipe end when inserting it through a wall so that no dust and dirt can enter.
- **The heat pump is only to be used in a sealed heating system. It must not be used as part of an open-vented system.**

Before continuing the installation of the heat pump, check the following points:

- The maximum system water pressure is 3 bar.
- Before continuing the installation of the heat pump, check the maximum system water pressure is 3 bar.

Please note, whilst these temperatures are possible, the flow temperatures should be avoided as it greatly reduces the efficiency.

- Always use material that are compatible with the water used in the system and with the materials used in the unit.
- Make sure the hose is connected to the pressure relief valve to avoid any water coming into contact with electrical parts.
- Air vents must be provided at all high points of the system. The vents should be located at points which are easily accessible for servicing. An automatic air purge valve is provided inside the heat pump. An automatic air purge valve is provided inside the heat pump, and always remains open.
- Take care that the components installed in the pipework can withstand the water pressure and temperature.
- Always ensure that the materials used in the system are compatible with the water being used and the materials used in the unit.

! WARNING !

Never leave the unit unattended during installation or servicing when the service panel is removed.

3.7.3 SLEEVING FOR PIPES AND CABLES

All pipes passing through external walls should be individually sleeved, using either copper or plastic pipe for the sleeve.

The inside diameter of this sleeving should be large enough to accommodate the insulation on heating system pipes, usually at least 6mm larger than the outside diameter of the insulation.

It is important that the sleeve is correctly built into the wall structure using a cement mortar or suitable filler.

The annular gap between the pipe/insulation and the sleeve should be even all round with at least one end sealed with a mastic sealant, to prevent the ingress of water or vermin whilst allowing the pipe to move and maintain the fire-resistant properties of the structure.

Whilst not essential, it is also recommended as good practise to sleeve any cables passing through external walls, following the basic requirements as given above. This will make it easier to remove/replace any cables in future, should it be necessary.

! WARNING !

Be sure to use only specified accessories and parts for installation works. Failure to use specified parts may result in water leakage, electric shocks, fire, or the unit falling from its mount.

3.7.4 SYSTEM CONNECTIONS

The system connections of the heat pump must be carried out using the flexible hoses, valves and fittings supplied with the heat pump controller kit.

The hydraulic circuit must be completed following the recommendations below:

1. The frost valve MUST be fitted on the return, between the

heat pump and the isolation valve, in the correct orientation, and the body insulated correctly. A second frost valve can be fitted on the flow pipe, in similar fashion to the return valve.

2. The system must have drain valves at the lowest points.
3. Air vents must be included at the highest points of the system.
4. A system pressure gauge must be installed internally, in proximity to the filling loop, in an easy to view location.
5. All pipework must be adequately insulated and supported.
6. The presence of solid particles in the water can obstruct the heat exchanger. Therefore, protect the heat exchanger using a magnetic filter such as a Grant Mag-One Duo magnetic filter.
7. After system assembly flush and clean the whole system, paying particular attention to the state of the filter.
8. A new installation must be thoroughly flushed and cleaned before filling and adding biocide/inhibitor.

! WARNING !

Do not touch water pipes during and immediately after operation as the pipes may be hot and could burn your hands.

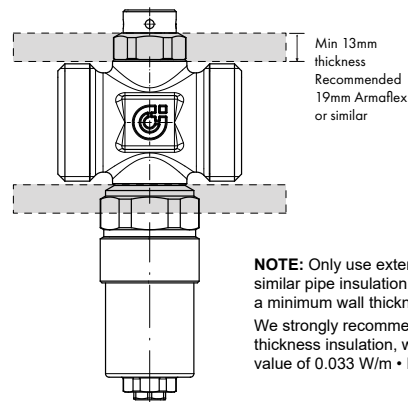

Figure 3-20: Insulated Frost Valve

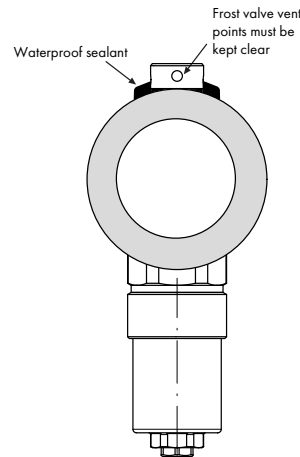

Figure 3-21: Insulated Frost Valve end view

3.8 SYSTEM VOLUME REQUIREMENTS

Grant Aerona R290 heat pumps requires a minimum heating system volume of 5 litres per useful kW. Refer to table 3-11 below

Table 3-11: System volume requirements

Model	Output (kW)	Minimum volume (L)
HPR290i40	4.0	20
HPR290i65	6.5	32.5
HPR290i90	9.0	45
HPR290i120	12.0	60
HPR290i160	15.5	77.5

This volume is to ensure the system always has sufficient

thermal capacity for the heat pump, allowing the heat output to be dissipated during normal operation, and also to assist in the defrost operation as and when that occurs.

This system volume can be achieved in one of several ways, as follows, depending on the system design and type:

- a. Using an Open-loop (or partial open loop) system, where the volume of the system pipework always open to the heat pump will usually exceed the required minimum volume (as given in Table 3-11).
It will be necessary to determine the actual system pipework volume to confirm that this exceeds the required minimum volume for the size of heat pump used.
- b. Using an S-plan system, or where other controls can isolate sections of the system pipework, e.g. UFH actuators, and the required minimum volume cannot be guaranteed at all times, a volumiser tank will be needed to achieve the required volume.

A 'Volumiser' tank is simply an insulated vessel used to increase the volume of the system to meet minimum volume requirements.

It will generally only have two connections, one inlet and one outlet.

Grant offer an insulated 50 litre Internal volumiser to be installed on the return to the heat pump. This is designed to provide both the necessary volume and, when required, assistance for defrost functions in cold ambient temperatures.

For further information on the Grant 50 litre Internal Volumiser (product code: HPIDVOL50), please refer to Grant IRLDOC0033.

3.9 HYDRAULIC DIAGRAMS

For information relating to the hydraulic concept drawings of the Grant Aerona Smart controller, refer to:

- DOC 0034 - smart heat pump system controller

! WARNING !

Do not use the heat pump to treat industrial process water, swimming pool water or domestic drinking water. Install an intermediate heat exchanger for all of the above cases.

3.10 AERONA SMART CONTROLLER

For information relating to the installation requirements of the Grant Aerona Smart controller, refer to your supplied manual:

- DOC 0034 - smart heat pump system controller

3.11 BEFORE YOU COMMISSION

3.11.1 FLUSHING AND CORROSION PROTECTION

To avoid the danger of dirt and foreign matter entering the heat pump the complete heating system should be thoroughly flushed out – both before the heat pump is operated and then again after the system has been heated and is still hot.

This is especially important where the heat pump is installed as a replacement for a boiler on an existing system. In this case the system should be first flushed hot, before the old boiler is removed and replaced by the heat pump.

For optimum performance after installation, this heat pump and the central heating system must be flushed in accordance with the guidelines given in BS 7593 'Treatment of water in domestic hot water central heating systems'.

This must involve the use of a proprietary cleaner.

After flushing, a suitable inhibitor and biocide should be used, such as Fernox F1 and F7 or alternatively Sentinel X100 and X700, specifically designed for use in air source heat pump installations. This provides long term protection against corrosion and scale and biological growth.

! NOTE !

When using water treatments additives, ensure that the volume of any volumisers, buffers and thermal stores are taken into account, in addition to the heating system pipework, when determining how much is required to correctly dose the system.

Grant Engineering strongly recommends that a Grant Mag

One Duo in-line magnetic filters (or equivalent*) is fitted in the heating system pipework. This should be installed and regularly serviced in accordance with the filter manufacturer's instructions.

* As measured by gauss. The Mag One Duo magnetic filter has a gauss measurement of 12000.

! WARNING !

Failure to fit a frost valve on the return pipe will invalidate warranty

3.11.2 ANTI-FREEZE FUNCTION SETTING

Ice formation can cause damage to the system water circuit, should the outdoor unit and pipework be exposed to sub-zero temperatures. It is essential that the complete water circuit, including all internal and external water pipework, valves, and pipework passing through external walls, must be insulated to reduce heat loss and a reduction in heating output and heat pump efficiency, and also to prevent freezing of external pipework during winter months. Refer to section 3.7.1.

The Grant Aerona R290 software includes special functions that use the heat pump to protect the entire system against freezing. This Frost protection is always active as long as the heat pump is powered on and cannot be de-activated or modified.

Mechanical anti-freeze valve(s) must be used to protect the system in the event of a power cut during freezing conditions. Refer to Section 3.13.

These antifreeze valve(s) must be installed as specified in the installation instructions provided by the manufacturer or supplier.

If the outdoor air temperature (measured by the heat pump outdoor temperature sensor T4) is below 7°C and the return (TA) or flow (TB) water temperature is below 6°C for a continuous 60 seconds period, the water pump will be activated.

After the water pump has run for 5 minutes:

- If TA or TB are 6°C or above, the water pump will run for additional 5 minutes and then stop.
- If TA or TB are below 6°C the compressor will run in silent mode until TA or TB are 15°. Refer to Section 8.5.6.

Under low ambient air conditions the water pump may operate repeatedly to provide frost protection when the heat pump is not operating, e.g. possibly through the night, until the heat pump starts the following morning. The cost to protect the heat pump from freezing in this way is small due to the low water pump power consumption.

If the water flow temperature in the system drops below 4°C and the ambient air temperature is below 4°C the unit will activate the plate heat exchanger heater. Refer to Section 8.5.8.

This anti-freeze protection function will only turn off when the ambient air or water temperature reaches 6°C. Refer to table 3-12.

Table 3-12: Anti-freeze ON/OFF conditions

Plate Heat Exchanger Heater Status	Heat Pump Status	Ambient Temp (°C)	Inlet/Outlet Water Temp (°C)
ON	Stand-by/OFF	< 4	< 4
OFF	ON	> 6	> 6

All conditions must be met to turn **ON** the plate heat exchange heater. Only **one** of the conditions are required to turn **OFF** the plate heat exchanger.

3.12 ANTIFREEZE VALVES

GLYCOL ANTI-FREEZE CANNOT BE USED WITH THE AERONA R290.

If the electrical power supply fails, mechanical anti-freeze valves are used to protect the system in the event of a power cut during freezing conditions.

These antifreeze valves must be installed as specified in the installation instructions provided by the manufacturer of the valves or the supplier. Grant expect the user to take adequate precautions to protect their home and contents in the event of a power cut; this includes the heat pump and heating system components.

! WARNING !

When using antifreeze valves, it is essential that any discharge of system water can drain away and not be allowed to run onto any adjacent paths or driveways where, in winter, this will result in icing and a potential hazard for anyone walking near the heat pump.

! NOTE !

The use of antifreeze valves does not avoid the need for biocide and inhibitor.

3.13 COMPLETION

Please ensure that the heat pump is commissioned and that it is signed by the householder/user.

This is required to activate the heat pump warranty.

Ensure that these and all other supplied installation and servicing instructions and the user instructions are handed over to the householder.

! WARNING !

Never leave the unit unattended during installation or servicing when the service panel is removed.

3.14 INSTALLATION CHECKLIST

Location and positioning

- The anti-vibration mounts are fitted (if required).
- The heat pump is fixed to the surface or mountings that it rests on.
- Maintenance clearances comply with those given in this manual.
- The position of the remote controller complies with the guidance given in the corresponding manual for the Grant Aerona Smart Controller.
- All safety requirements have been complied with.

! WARNING !

Ensure all installation work is completed with full consideration of extreme weather conditions, e.g. strong winds, heavy rain fall. For wall mounted installations, improper installation work may result in accidents due to equipment falling.

Water circuit pipework and appliances

- Water connections have been carried out as per the information in this manual.
- All water connections are tight with no leaks.
- The magnetic in-line filter is installed on the primary circuit return as close to the heat pump as possible but still within the building and in a position that is easy to access for maintenance.
- The pressure gauge and filling loop is installed on the sealed system pipework or expansion vessel manifold.
- The connection pipes are suitably supported so that these do not weigh on the appliance.
- The expansion vessel installed on the heating circuit is suitably sized.
- Any volumiser tank required is connected to the heat pump (refer to Section 3.9).
- The water circuit has been thoroughly flushed.
- The air vent valves are installed at the highest points on the system.
- There is no air in the system (vent if necessary).

- The isolation valves are installed on the inlet/outlet of system circuit.
- The drain valves are installed at the lowest points in the system.
- The flexible hoses are installed on the inlet/outlet of system circuit.
- The system water content complies with that specified in this manual.
- Frost valve (s) fitted as required
- The DHW immersion heater has been installed in DHW cylinder for Legionella prevention.
- Suitable water flow rate for operation of the entire heat pump is achieved as specified in this manual.
- All pipes are insulated with suitable vapour barrier material to prevent formation of condensation and heat loss, with control and shut-off devices protruding from the insulation.

! WARNING !

Do not touch water pipes during and immediately after operation as these may be hot and could burn your hands.

Electrical connections

- All electrical connections are secure.
- Electrical connections have been carried out correctly.
- Voltage is within a tolerance of 10% of the rated voltage for the heat pump (230V).
- Electrical power supply complies with the data on the rating plate and as specified in this manual.
- The earth wires are connected securely.

! WARNING !

Make sure all wiring is secure. Use the specified wires and ensure that terminal connections or wires are protected from water and any adverse external forces. Incomplete or loose connections may cause a fire.

3.15 AERONA R290 PACKAGING

Grant is making positive steps in achieving more sustainable business operations. As part of Grant Project Zero, our company wide carbon reduction programme, we are reviewing the way our products are packaged to ensure we reduce waste wherever possible.

Through eliminating the use of unnecessary packaging and utilising recycled, recyclable, and compostable materials, we can help lessen the environmental impact of our products.

The packaging for your Aerona R290 air source heat pump should be handled as follows:

Table 3-13: Handling packaging

Packaging	Material	Handling
Outer Carton	Cardboard	Please recycle
Packing Tape	Paper-based	Please recycle
Pallet strapping	Polyester PET	Please recycle
Pallet	Wood	Please recycle
Protective Bag	Low Density Polyethylene	Please recycle
Accessory Carton	Paper-based	Please recycle
Packaging label	Paper-based	Please recycle
Manual Bag	Cornstarch Blend	Compostable

3.14 R290 HEAT PUMP INSTALLATION SCHEMATIC

3.14.1 PREPLUMBED CYLINDER

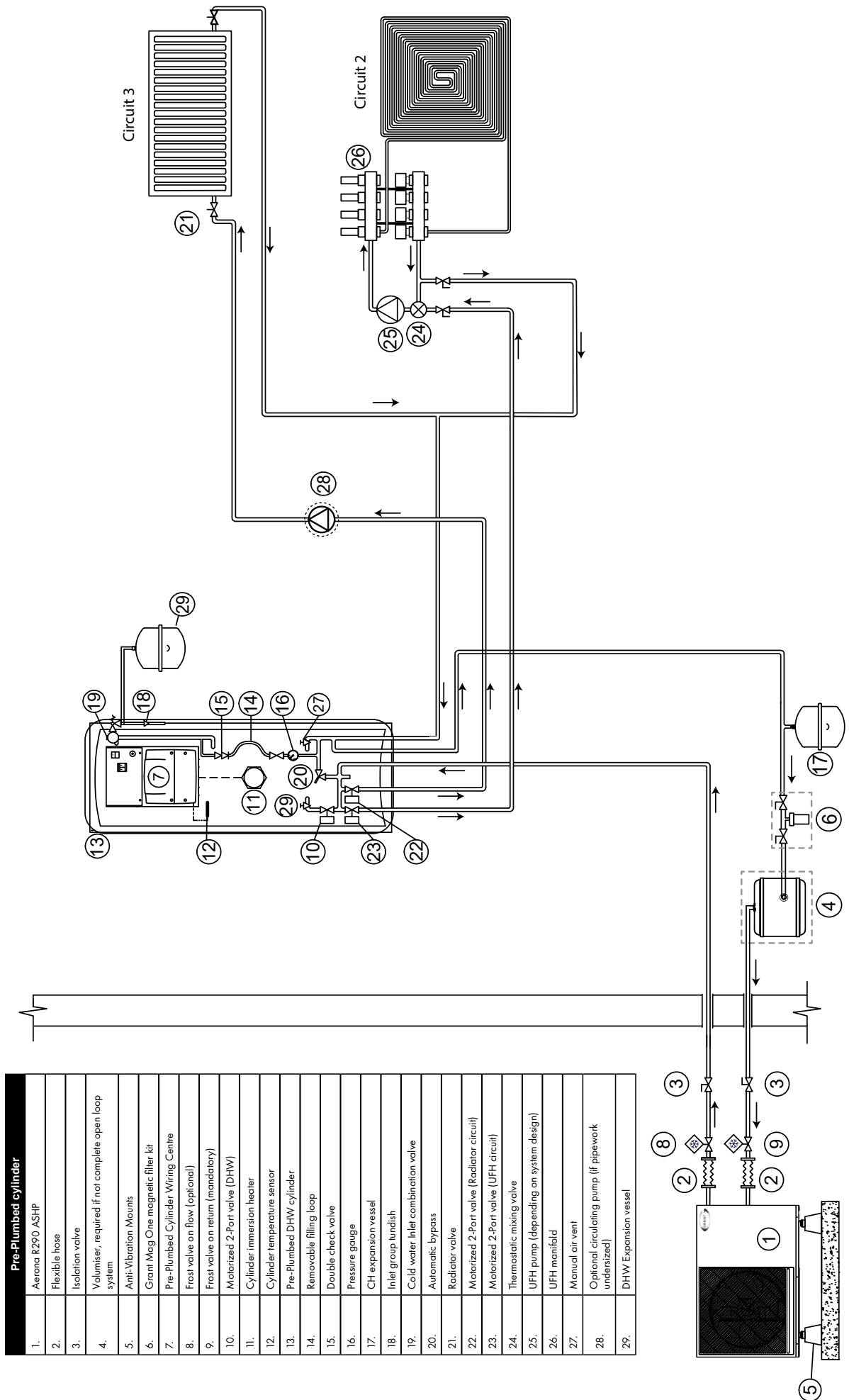

3.14.2 AWAVE CYLINDER

Awave	
1.	Aerona R290 ASHP
2.	Flexible hose
3.	Isolation valve
4.	Volumiser, required if not complete open loop system
5.	Anti-Vibration Mounts
6.	Grant Mag One magnetic filter kit
7.	Awave Wiring Centre (In Awave casing)
8.	Frost valve on flow (optional)
9.	Frost valve on return (mandatory)
10.	Motorized 2-Port valve (DHW) (In Awave casing)
11.	Cylinder immersion heater (In Awave casing)
12.	Cylinder temperature sensor (In Awave casing)
13.	DHW cylinder (In Awave casing)
14.	Removable filling loop (In Awave casing)
15.	Double check valve (In Awave casing)
16.	Pressure gauge (In Awave casing)
17.	CH and DHW expansion vessels (In Awave casing)
18.	Tundish (In Awave casing)
19.	Cold Water Inlet combination valve (In Awave casing)
20.	Automatic bypass (In Awave casing)
21.	Radiator valve
22.	Motorized 2-Port valve (Radiator circuit) (In Awave casing)
23.	Motorized 2-Port valve (UFH circuit) (In Awave casing)
24.	Thermostatic mixing valve
25.	UFH pump (Optional depending on system design)
26.	UFH manifold
27.	Manual air vent (In Awave casing)
28.	Tundish (In Awave casing)
29.	Optional circulating pump (If pipework undersized)

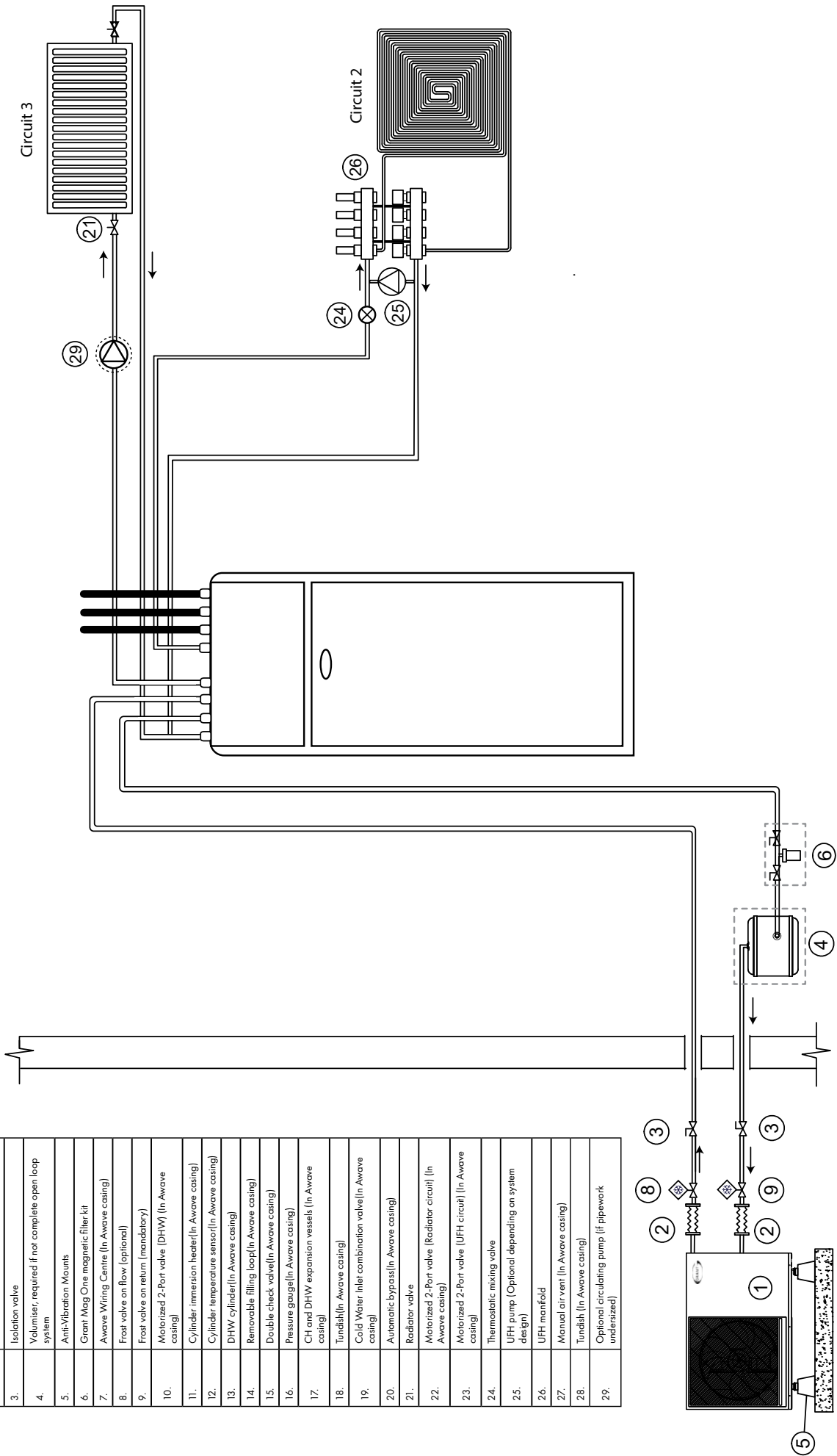

3.14. STANDARD CYLINDER WITH 2-PORT VALVES

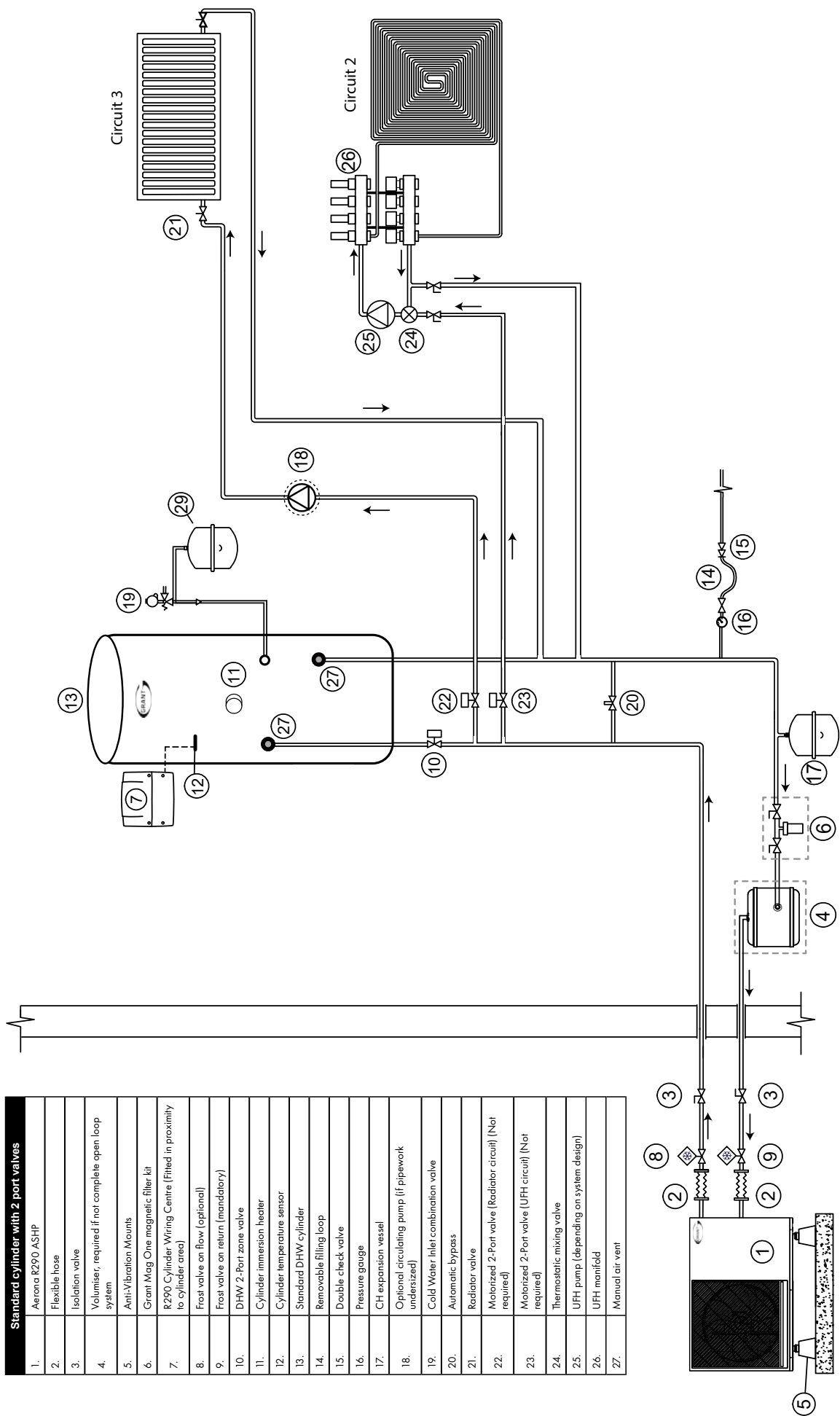

Standard cylinder with 2 port valves	
1.	Aeraon R290 ASHP
2.	Flexible hose
3.	Isolation valve
4.	Volumiser, required if not complete open loop system
5.	Anti-Vibration Mounts
6.	Grant Mag One magnetic filter kit
7.	R290 Cylinder Wiring Centre (Fitted in proximity to cylinder area)
8.	Frost valve on flow (optional)
9.	Frost valve on return (mandatory)
10.	DHW 2-Port zone valve
11.	Cylinder immersion heater
12.	Cylinder temperature sensor
13.	Standard DHW cylinder
14.	Removable filling loop
15.	Double check valve
16.	Pressure gauge
17.	CH expansion vessel
18.	Optional circulating pump (if pipework undersized)
19.	Cold Water Inlet combination valve
20.	Automatic bypass
21.	Radiator valve
22.	Motorized 2-Port valve (Radiator circuit) (Not required)
23.	Motorized 2-Port valve (UFH circuit) (Not required)
24.	Thermostatic mixing valve
25.	UFH pump (depending on system design)
26.	UFH manifold
27.	Manual air vent

3.14.4 STANDARD CYLINDER WITH 3-PORT VALVE

Standard cylinder with 3 port valve	
1.	Aerona R290 ASHP
2.	Flexible hose
3.	Isolation valve
4.	Volumiser, required if not complete open loop system
5.	Anti-Vibration Mounts
6.	Grant Mag One magnetic filter kit
7.	R290 Cylinder Wiring Centre (Fitted in proximity to cylinder area)
8.	Frost valve on flow (optional)
9.	Frost valve on return (mandatory)
10.	3-Port valve (Powered or spring loaded)
11.	Cylinder immersion heater
12.	Cylinder temperature sensor
13.	Pre-Plumbed DHW cylinder
14.	Removable filling loop
15.	Double check valve
16.	Pressure gauge
17.	CH expansion vessel
18.	Optional circulating pump (if pipework undersized)
19.	Cold Water Inlet combination valve
20.	Automatic bypass (Not required)
21.	Radiator valve
22.	Thermostatic mixing valve
23.	UFH pump (Optional depending on system design)
24.	UFH manifold
25.	Air vent
26.	DHW Expansion vessel

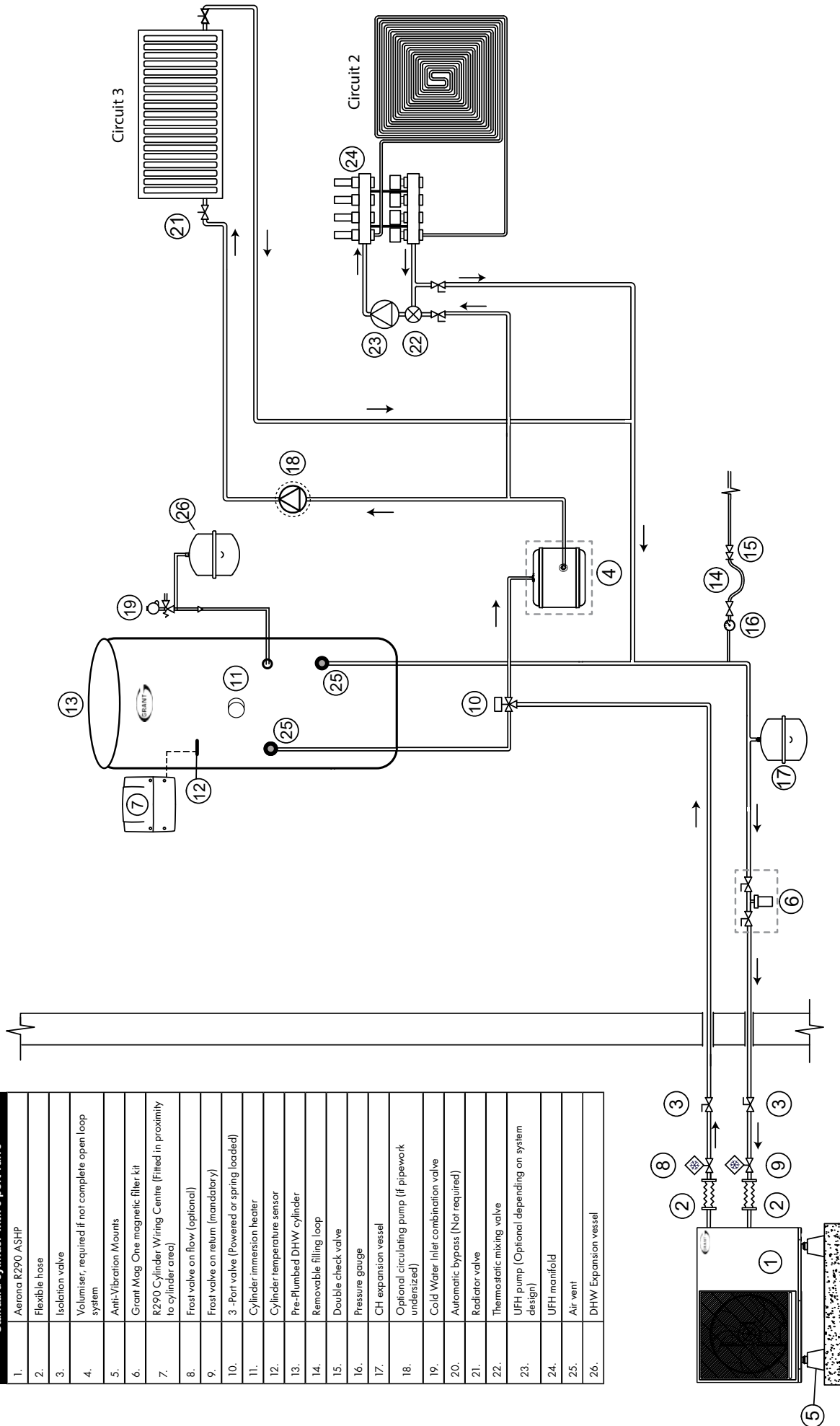

4 SEALED SYSTEMS

4.1 INTRODUCTION

All Grant Aeron R290 heat pumps must be used with sealed systems complying with the requirements of BS EN 12828, BS EN 12831 and BS EN 14336.

The system must be provided with the following items:

- Diaphragm expansion vessel complying with BS EN 13831
- Pressure gauge
- Pressure relief (safety) valve
- Approved method for filling the system

The minimum system water volume required is 5 litres per kW of heat pump output. Refer to section 3.9.

EXPANSION VESSEL

The expansion vessel can be fitted in either the return or flow pipework. To reduce the operating temperature of the expansion vessel, position it below the pipe to which it is connected.

The expansion vessel may be positioned away from the system, providing the connecting pipe is not less than 13mm diameter. If the expansion vessel is connected via a flexible hose, care must be taken to ensure that the hose is not twisted.

The unit comes equipped with a Return and Flow for connection to water circuit. It is important that the circuit is installed by a trained and qualified technician and complies with local laws and regulations.

It should be noted that the unit is designed to be used in a sealed heating systems only. Any attempt to use the unit in an open vented system circuit can lead to excessive corrosion of the water piping.

! NOTE !

Ensure that the expansion vessel used is of sufficient size for the system volume.

Refer to BS 7074:1:1989 or The Domestic Heating Design Guide for sizing the required vessel.

PRESSURE GAUGE

The pressure gauge must have an operating range of 0 to 4 bar. It must be located in an accessible place next to the filling loop for the system.

SAFETY VALVE

The safety valve (provided with the heat pump) is set to operate at 3 bar.

The safety valve is connected to a discharge pipe which will allow the discharge to be seen, but cannot cause injury to persons or damage to property.

FILLING LOOP

Provision should be made to replace water lost from the system. This can be done manually (where allowed by the local water undertaking) using an approved filling loop arrangement incorporating a double check valve assembly.

The filling loop must be isolated and disconnected after filling the system.

HEATING SYSTEM

75degC, but these high flow temperatures should be avoided to ensure efficiency.

An automatic air vent should be fitted to the highest point of the system.

If thermostatic radiator valves are fitted to all radiators, a system by-pass must be fitted. The by-pass must be an automatic type and correctly set when the system is commissioned.

All fittings used in the system must be able to withstand pressures up to 3 bar. Radiator valves must comply with the requirements of BS 2767:1991.

One or more drain taps (to BS 2879) must be used to allow the system to be completely drained.

4.2 FILLING THE SEALED SYSTEM

Filling of the system must be carried out in a manner approved by the local Water Undertaking.

! WARNING !

Only ever fill or add water to the system when it is cold and the heat pump is off. Do not overfill.

The procedure for filling the sealed system is as follows:

1. Check the air charge pressure in the expansion vessel BEFORE filling the system.
The expansion vessel charge pressure should always be approximately 0.2 bar lower than the maximum static head of the system, at the level of the vessel (1 bar = 10.2 metres of water).
The charge pressure must not be less than the actual static head at the point of connection.
2. Check that the small cap (or screw) on all automatic air vents is open at least one turn. The air vent within the heat pump remains open at all times.
3. The automatic air vent in the heat pump should be open with at least 2 turns from the factory. This should be checked. Remove the top panel and when necessary the right hand panel to access the automatic air vent. Refer to Figure 4-1 and section 1.10.
4. Ensure that the flexible filling loop is connected and that the double check isolation valve connecting it to the water supply is closed. A valve is open when the operating lever is in line with the valve, and closed when it is at right angles to it.
5. Open the fill point valve.
6. Gradually open the double check valve from the water supply until water is heard to flow.
7. When the needle of the pressure gauge is 2.0 bar approximately, close the valve.
8. Vent each radiator in turn, starting with the lowest one in the system, to remove air.
9. Continue to fill the system until the pressure gauge indicates between 0.5 and 1.0 bar. Close the fill point valve. The system fill pressure (cold) should be 0.2 - 0.3 bar greater than the vessel charge pressure – giving typical system fill pressures of approx 0.5 bar for a bungalow and 1.0 bar for a two storey house.
Refer to the Domestic Heating Design Guide for further information if required.
10. Repeat steps 8 and 9 as required until system is full of water at the correct pressure and vented.
11. Water may be released from the system by manually operating the safety valve until the system design pressure is obtained.
12. Close the fill point and double check valves either side of the filling loop and disconnect the loop.
13. Check the system for water soundness, rectifying where necessary.

The valve is supplied open from the factory and when installed, will automatically discharge the air from the heating system during commissioning and operation.

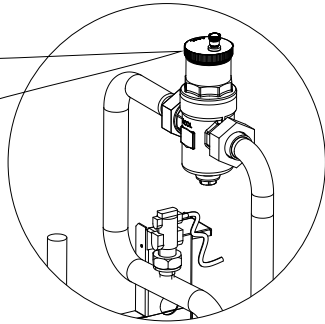

Figure 4-1: Automatic Air Vent

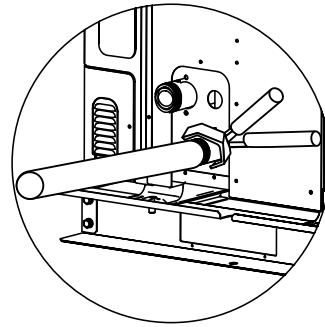

Figure 4-2: Water circuit connection

! NOTE !

The air charge pressure may be checked using a tyre pressure gauge on the expansion vessel Schraeder valve. The vessel may be re-pressurised, when necessary, using a suitable pump. When checking the air pressure, the water in the heating system must be cold and the system pressure reduced to zero.

! NOTE !

Never use Zinc-plated parts in the water circuit. Excessive corrosion of these parts may occur as copper piping is used in the heat pump internal water circuit.

! NOTE !

When using a 3-port diverter valve in the water circuit, preferably chose a ball type valve to guarantee full separation between the domestic hot water and space heating water circuit.

4.3 PRESSURE RELIEF (SAFETY) VALVE OPERATION

Check the operation of the pressure relief (safety) valve as follows:

1. Turning the head of the valve anticlockwise until it clicks. The click is the safety valve head lifting off its seat allowing water to escape from the system.
2. Check that the water is escaping from the system.
3. Top-up the system pressure, as necessary.

! NOTE !

The expansion vessel air pressure, system pressure and operation of the pressure relief valve must be checked on each service. Refer to Section 10

4.4 WATER CIRCUIT CONNECTION

Water connection must be made correctly in accordance with labels on the outdoor unit, with respect to the Return and Flow.

If air, moisture or dust gets in the water circuit, problems may occur. Therefore, always take the following into account when connecting the water circuit:

- Use only clean pipes
- Cover the pipe end when inserting it through a wall to prevent dust and dirt from entering
- Use a good thread sealant to seal the connections. The sealant must be able to withstand the pressures and temperatures of the system
- When using non-copper metallic piping, be sure to insulate the two different materials from each other to prevent galvanic corrosion
- Copper is a soft material, so use appropriate tools for connecting the water circuit. Inappropriate tools will cause damage to the pipes

4.5 DRAINING THE WATER CIRCUIT

If it is necessary for any reason to drain the water from the primary circuit, ensure that there is no water remaining in the flow switch. If any water is not drained out, may freeze under winter conditions and damage the flow switch.

To avoid this, the flow switch should be removed, dried, and reinstalled in the heat pump.

To do this:

1. Turn the body of the flow switch anti clockwise to disengage and remove it from the connection on the pipework.
2. Ensure there is no water remaining in the flow switch. Refer to Figure 4-3.
3. Re-fit the flow switch into the connection on the pipework and turn the body clockwise to secure it in position.

! NOTE !

To dry the flow switch completely, remove it turning the connection anti clockwise.

! CAUTION !

Be careful not to deform the unit's piping by using excessive force when connecting the piping. Deforming the piping can cause the unit to malfunction and invalidate the warranty.

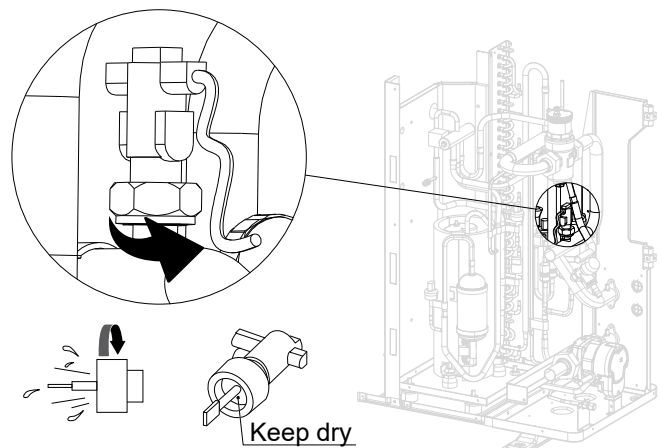

Figure 4-3: Flow switch in the heat pump

5 DOMESTIC HOT WATER

5.1 TEMPERATURE CONTROL

By default, the supplied Grant Aerona Smart Controller will prioritise any DHW demand that is made. The CH pump/valve terminals are de-energised as the DHW terminals are activated.

Once DHW is being provided, the flow temperature will adjust to the target temperature specified on the Aerona Smart controller for the DHW cylinder. The heat pump will stop when the cylinder temperatures reaches the desired target temperature, and should the temperature of the cylinder fall below the set level within the scheduled period the heat pump will re-engage.

A DHW demand should not exceed 60 minutes in a single period. This is to avoid excessive heat loss in the space heating circuit(s). The supplied Aerona Smart controller allows the user to configure the demand in 30 minute segments.

In addition, the end user can create a 'Boost' DHW cylinder demand via Grant Aerona Smart Controller, using the heat pump. This 'Boost' will heat the cylinder to the preset target temperature where it will then deactivate.

We recommend, if timing heating the DHW that up to 4 x 1 hour DHW demand periods to be scheduled in a day with at least a 1 hour gap between them.

The Grant Aerona smart controller can also be configured to aid the heat pump using the inbuilt immersion heater in the heat pump itself.

5.2 GRANT CYLINDERS

As the water temperature from the heat pump is lower than from a traditional system using a boiler, a much larger coil is required inside the cylinder to transfer the heat efficiently.

The Grant range of hot water cylinders are specifically designed for use with heat pumps.

To ensure that a 5 to 8K temperature difference is maintained between the cylinder flow and return, the correct Grant cylinder must be selected to match the heat pump output.

Failure to use the correct cylinder can result in a reduced heat transfer in the cylinder and a lower temperature differential.

5.2.1 CYLINDER CAPACITY

To calculate the minimum cylinder capacity for a dwelling, use the following formula:

- Minimum cylinder capacity to meet Total daily DHW demand = (Number of people x 45 litres) + 40 litres
- Where the Number of people (Np) = Number of bedrooms +1

Example:

To calculate the cylinder capacity for a 3-bedroom dwelling:

$$\begin{aligned}\text{Minimum cylinder capacity} &= (Np \times 45) + 40 \text{ litres} \\ &= (4 \times 45) + 40 \\ &= 220 \text{ litres}\end{aligned}$$

5.3 LEGIONELLA

For protection against Legionella the temperature can be periodically to 60°C using the supplied Grant Aerona Smart Controller.

It is possible to use the Aerona R290 heat pump to raise the DHW cylinder to around 50 to 55°C during the standard operating modes.

The Grant Aerona Smart Controller also allows the cylinder immersion element to be used to raise the temperature to 60°C for one hour weekly to sterilise the cylinder against Legionella.

Refer to your supplied Installation and Operating instructions for further information.

- DOC 0034 - smart heat pump system controller
- DOC 0033 - for systems with Grant Smart standard and pre-plumbed cylinder

6 ELECTRICAL

6.1 POWER SUPPLY

Use a dedicated power supply with a correctly sized circuit breaker.

The final power supply connection must be made from a weatherproof lockable isolator located outside the building.

The cable should be either armoured or run in a flexible conduit between the isolator and the heat pump. The power supply cable should be sized by a qualified electrician in accordance with current wiring regulations.

The DC residual current measured is less than 10A on all models, therefore a Type F Residual Current Device (RCD) can be used on all Aerona R290 heat pumps.

The isolator must be:

- Within 1 metre of the heatpump
- Not fixed into the heatpump itself
- Fitted level with the top of the heatpump

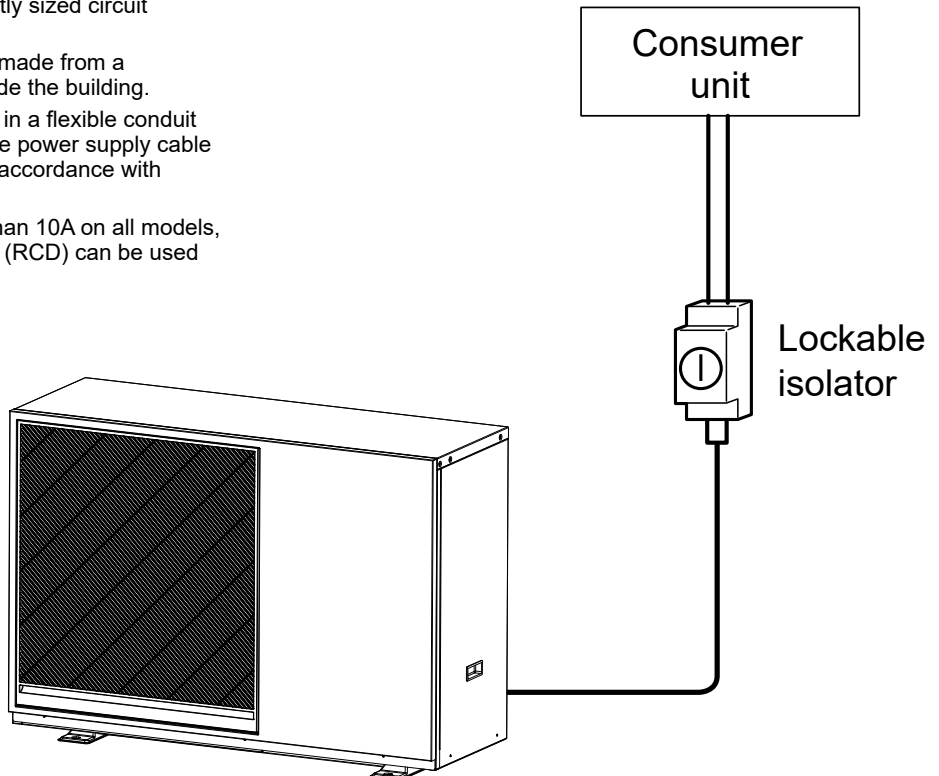

Figure 6-1: Heat pump, isolator and consumer unit

! NOTE !

A Type F Residual current device (RCD) can be used with all Aerona R290 heat pumps with DC residual current measuring under 10mA across all models.

Table 6-1: Electrical supply details

Model	Voltage (V)	Frequency (Hz)	Power cable* Min (mm ²)	MCB Size (A)	Max Running current (A)
HPR290i40	230	50	6.0*	25	21.3
HPR290i65	230	50	6.0*	32	25.8
HPR290i90	230	50	10.0*	32	29.8
HPR290i120	230	50	10.0*	40	37.8
HPR290i160	230	50	10.0*	50	42.3

* Indicative only, Final cable size to be determined by installer based on Amperage and distance. Power cable should be sized by a qualified electrician in accordance with current wiring regulations.

Select circuit breaker that has a contact separation in all poles not less than 2mm providing full disconnection through a double pole isolator where:

Table 6-2: Fan input power

Model	Fan Input power (W)	
	Single fan	Dual fan
HPR290i40	100	n/a
HPR290i65	170	n/a
HPR290i90	170	n/a
HPR290i120	100	200
HPR290i160	100	200

6.1.1 CONNECTING MAINS SUPPLY

1. Remove the side panel of the R290 heat pump (left side panel when viewing from the rear) and the Hydraulic PCB module panel. Refer to Figure 6-2.
2. Slot the power cable through the outer section of the supplied cable gland.
3. Remove the in situ hole cover.
4. Insert the power cable through the High voltage wire slot incorporated into the body of the heat pump (located close to the Flow and return. Refer to Figures 6-3, 6-4, 6-5 and Table 6-3).
5. Pass the power cable through the inner section of the supplied cable gland and unite with the outer section with a loose connection.

6. Guide the cable into the hydraulic PCB housing through the holes in the bottom.
7. Open the cable clamp and pass the power cable through, leaving sufficient cable length to connect to the power supply terminals.

! NOTE !

In the case of long cable runs, selection of correct cable must be done in accordance with BS 7671 (IET Wiring Regulations), or IS-10101 NREI edition 5 for ROI

HPR290i40

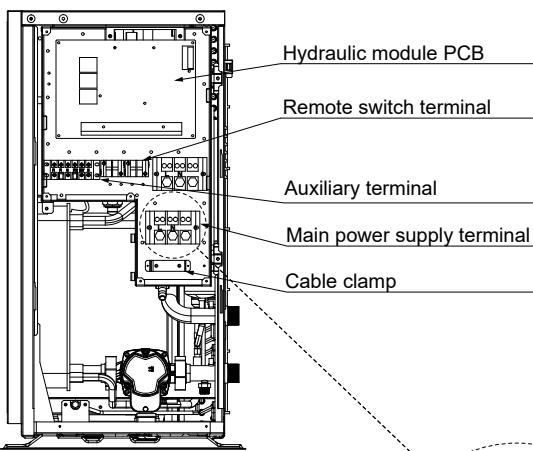

HPR290i65 & HPR290i90

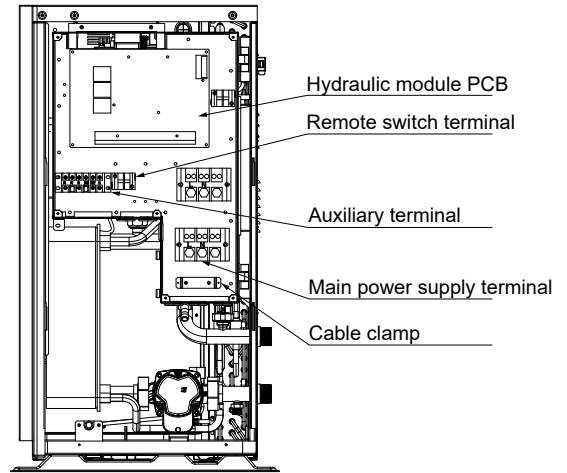

HPR290i120

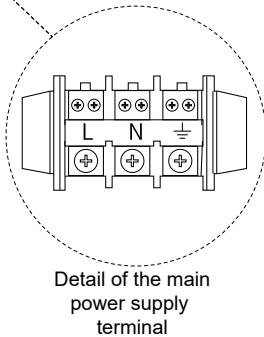
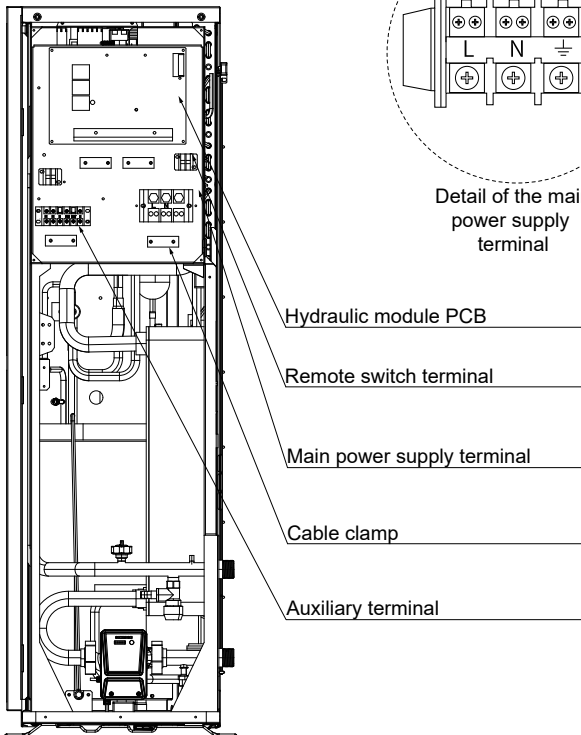

HPR290i160

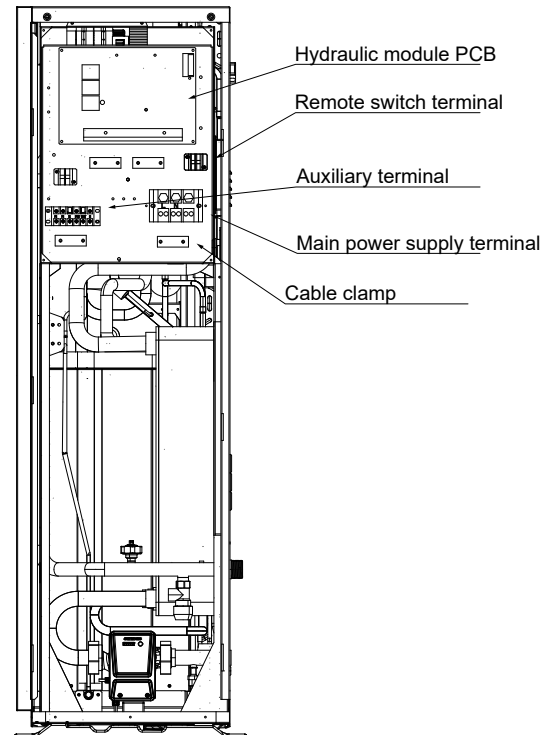

Figure 6-2: Side view for Mains and Hydraulic PCB connection

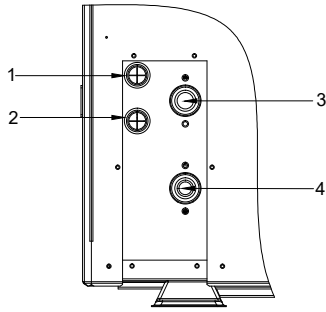

Figure 6-3: Wiring Holes for 4kW model

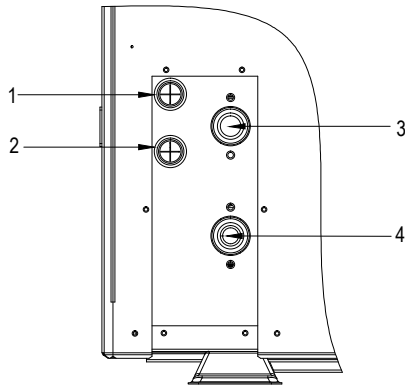

Figure 6-4: Wiring Holes for 6.5kW and 9kW models

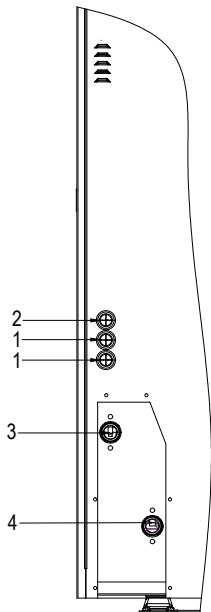

Figure 6-5: Wiring Holes for 12kW and 16kW models

Table 6-3: Wiring hole diagram key

Item	Description
1	High Voltage cable
2	Low voltage cable
3	Flow connection
4	Return connection

! NOTE !

Cable and circuit breakers should be to EN standards.

- Strip the ends of connecting cables in accordance with Figure 6-6.
- Crimp terminals with insulating sleeves can be used if required as illustrated in Figure 6-6 for connecting the wires to the terminal block. Stranded conductors shall not be soldered.
 - Use a circuit breaker with a 3 mm clearance of air gap between the contacts.
 - Be sure to FULLY insert the cable cores into the proper position of the terminal block.
 - Faulty wiring may cause not only abnormal operation but also damage to Hydraulic PCB board.
 - Fasten each terminal screw securely.
 - To check the connections are secure, pull the cable slightly.
 - Fix cables into the cable clamp.

! CAUTION !

It is important that the cable is stripped back 10mm. If shorter, it is possible to clamp down onto the insulation. If longer, a short circuit may occur.

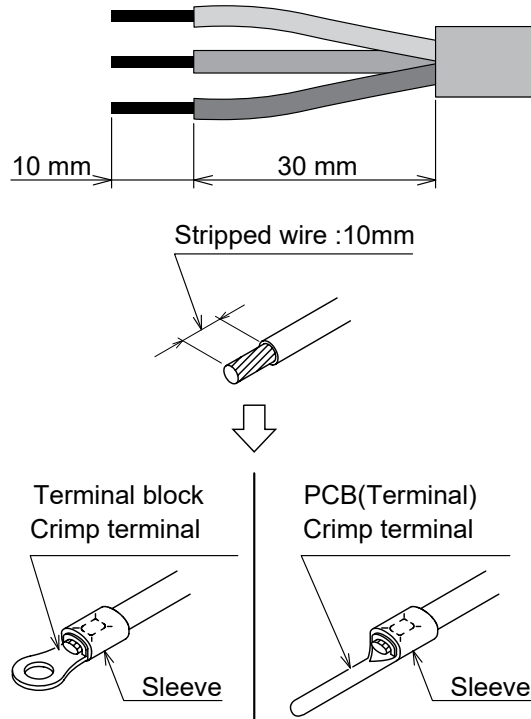

Figure 6-6: Circular wiring connection

! CAUTION !

If you do not use circular wiring terminals ensure you leave at least 30mm of exposed wire to wrap around the screw thread of the connection terminal.

- Connect wires to the corresponding terminals on the heat pump and screw the fastenings securely into place.
- Once this and any other connections are made to the Hydraulic PCB, refit the panel for the Hydraulic PCB enclosure with the screws previously removed.
- Refit the side panel for the heat pump with the screws previously removed.

6.2 TIGHTENING TORQUES

When tightening fixings:

- Use the correct screwdriver. Small screwdrivers can damage the screw head and prevent appropriate tightening.
- Over-tightening the terminal screws can cause damage.

! WARNING !

When using crimp type terminals, ensure the terminal screws are sufficiently tightened, otherwise overheating may occur and possibly cause extensive damage inside the heat pump. Do not over tighten.

6.3 CONNECTION OF CONTROLLER

For information relating to the connection of the Grant Aerona Smart Controller, refer to your supplied manual

- DOC 0034 - smart heat pump system controller

6.4 INTERNAL ELECTRIC HEATERS

The Grant Aerona R290 comes factory fitted with a number of electric heaters that aid various internal functions within the heat pump. Refer to table 6-4 for heaters and related electrical specifications.

- The base tray heater melts any frozen condensate collected in the base of the heat pump. Refer to Section 1.2.
- The compressor crankcase heater is used to prevent refrigerant from mixing with compressor oil when the compressors are stopped. Refer to Section 8.2.2 for more information.
- The plate heat exchanger heater is activated in frost protection cycles to stop ice from forming inside the plate heat exchanger. Refer to Section 8.5.8 for more information.
- Inline booster heater

Table 6-4: Base tray, Compressor crankcase and Plate Heat Exchanger heater specifications

Base tray heater specification					
Specification	Unit	Base Tray	Compressor Crankcase	Plate Heat Exchanger	Inline Immersion
Voltage	V	230	230	230	230
Power	W	43.70	27.30	21.90	3000
Maximum temperature	°C	180	180	180	65
Current	A	0.19	0.12	0.10	13
Resistive load					
Resistance at 20 °C	Ω	1210 ± 7%	1936 ± 7%	2420 ± 7%	18 ± 7%

Table 6-5: First Fixing Wiring

Description	Max Current (A)	Cable		MCB Size (A)
		Core	CSA mm ²	
Main Supply Grant Aerona 290 4kW – HPR290i40	21.3	3	6*	25
Main Supply Grant Aerona 290 6.5kW – HPR290i65	25.8	3	6*	32
Main Supply Grant Aerona 290 9kW – HPR290i90	29.8	3	10*	32
Main Supply Grant Aerona 290 12kW – HPR290i120	37.8	3	10*	40
Main Supply Grant Aerona 290 16kW – HPR290i160	42.3	3	10*	50
Signal Cable – Heat Pump to Heat Pump Wiring Centre	N/A	2	0.75 (over 30m to be shielded)	N/A
Fuseboard to pre plumb cylinder/Awave/Wiring Centre	18	3	2.5	20
Grant Wired Room Thermostat	N/A	4	Cat 6	N/A
Heat Enable Cable from 3rd Party UFH Controls	N/A	5	0.75	N/A

*Indicative only. Final cable size to be determined by installer based on Amperage and distance.

6.5 WIRING CENTRE LAYOUT

230V AC / 50Hz

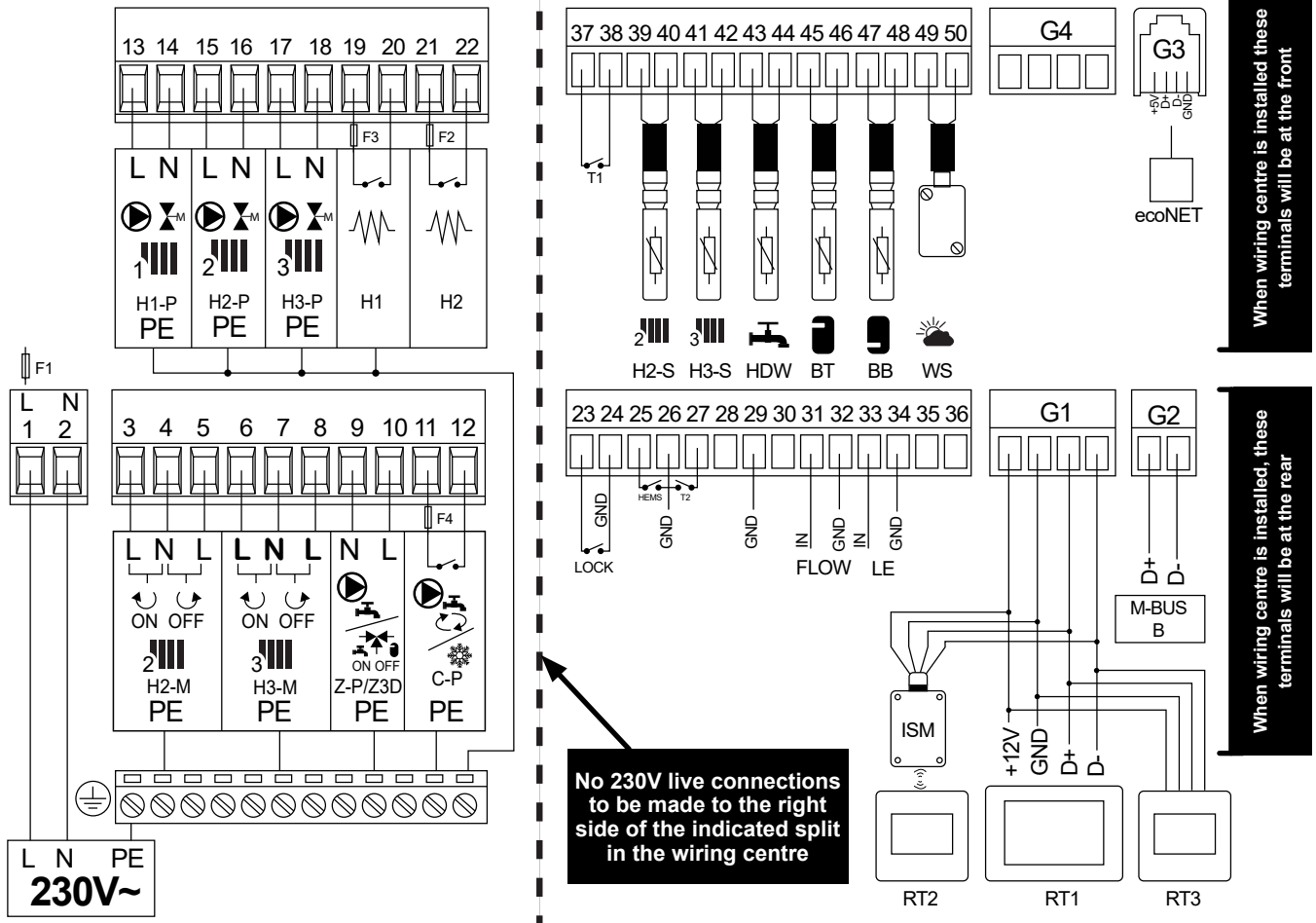

Figure 6-7: Wiring centre - Terminals

Table 6 -6: Wiring Centre Terminals

LABEL	TERMINAL NUMBERS	DESCRIPTION
230V ~	1 & 2	Mains Live and Neutral
H2-M	3, 4 & 5	Circuit 2 Mixing valve - 2 x 230V Lives (ON and OFF) and Neutral
H3-M	6, 7 & 8	Circuit 3 Mixing Valve - 2 x 230V Lives (ON and OFF) and Neutral
Z-P/Z3D	9 & 10	DHW Pump/3-Port Diverter Valve
C-P	11 & 12	Secondary Circulation Switched Relay (must be Externally fused 'F4')
Flow	31 & 32	Flow sensor I/O & Ground
LE	33 & 34	Electricity Meter
G1	Terminal Set	Touchscreen & Thermostat connection terminals (RT1, RT2, RT3)
G2	M-BUS	Modbus connection to the Aeraona Heat pump.
G3	G3 Socket	Connection port for ecoNET cable
G4	Terminal Set	+12V, Ground, D+, D-
H1-P	13 & 14	Circuit 1 230V Switched Live and Neutral
H2-P	15 & 16	Circuit 2 230V Switched Live and Neutral
H3-P	17 & 18	Circuit 3 230V Switched Live and Neutral
H1	19 & 20	Switch for Immersion Relay (Back-up heater - must be Externally fused 'F3')
H2	21 & 22	Switch for Immersion Relay (DHW Cylinder - must be Externally fused 'F2')
H2-S	39 & 40	Circuit 2 Water temperature sensor
H3-S	41 & 42	Circuit 3 Water temperature sensor
HDW	43 & 44	DHW Cylinder Water temperature sensor
BT	45 & 46	Buffer Upper Water temperature sensor
BB	47 & 48	Buffer Lower/Low Loss Header temperature sensor
WS	49 & 50	Outdoor Weather sensor
T1	37 & 38	External Volt-free switch for Circuit 1
T2	26 & 27	External Volt-free switch for Circuit 2 or 3
LOCK	23 & 24	Not used
HEMS	25	Not used

6.7 SYSTEM WIRING DIAGRAMS
6.7.1 PREPLUMBED, AWAVE & STANDARD CYLINDER 2-PORT

Wiring Centre
ISM - Wireless receiver
RT2 - Wireless room stats
RT1 - Touchscreen display
RT3 - 12VDC room stats
G1 - RT1, RT2, & RT3 inputs
G2 - Heat pump modbus
G3 - Wi-fi hub
G4 - N/A

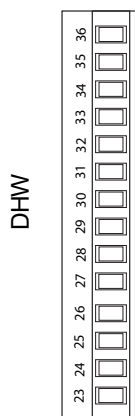
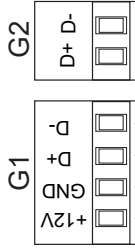
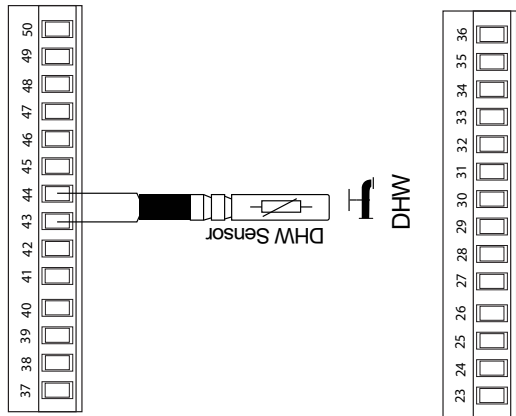
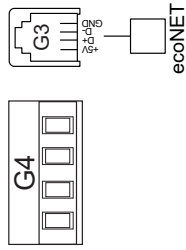

NOTE
 Drawing for Pre-plumbed, Awave and standard cylinder options, with 2 port zone valves on open loop heating systems.

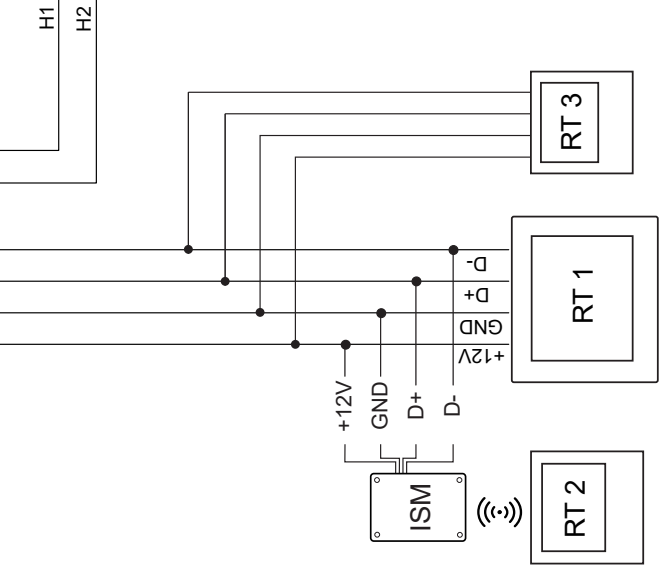

No 230V live connections to be made to the right side of the indicated split in the wiring centre

Low voltage side

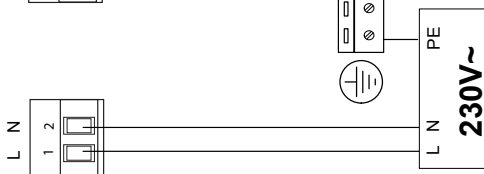
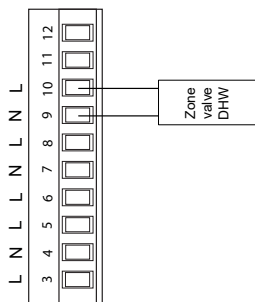
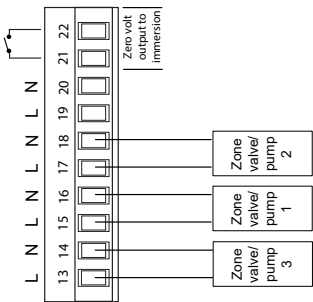

*Zone valve 3 (not supplied with Awave & Preplumbed cylinders)
 Must only be used for non mixed circuits (Radiators)

Mains voltage side - 230V AC

6.7.2 PREPLUMBED, AWAVE & STANDARD CYLINDER 2-PORT

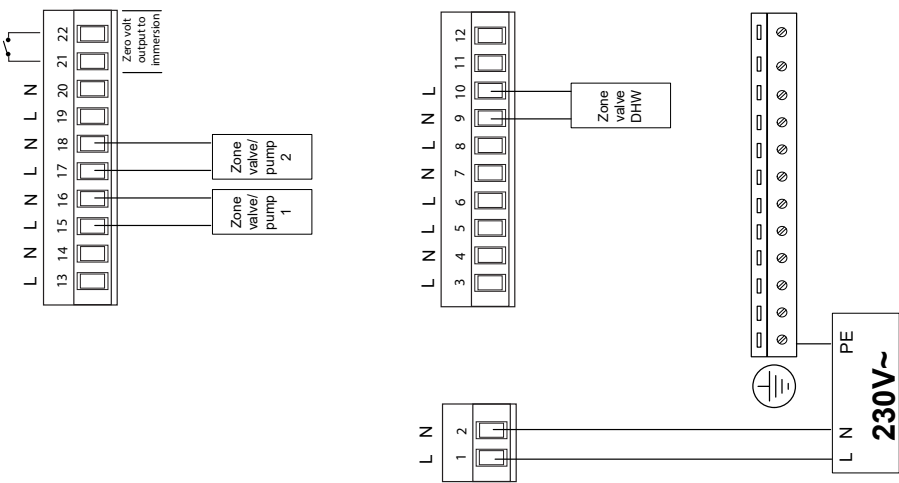

*Zone valve 3 (not supplied with Awake & Preplumbed cylinders)
Must only be used for non mixed circuits (Radiators)

Mains voltage side - 230V AC

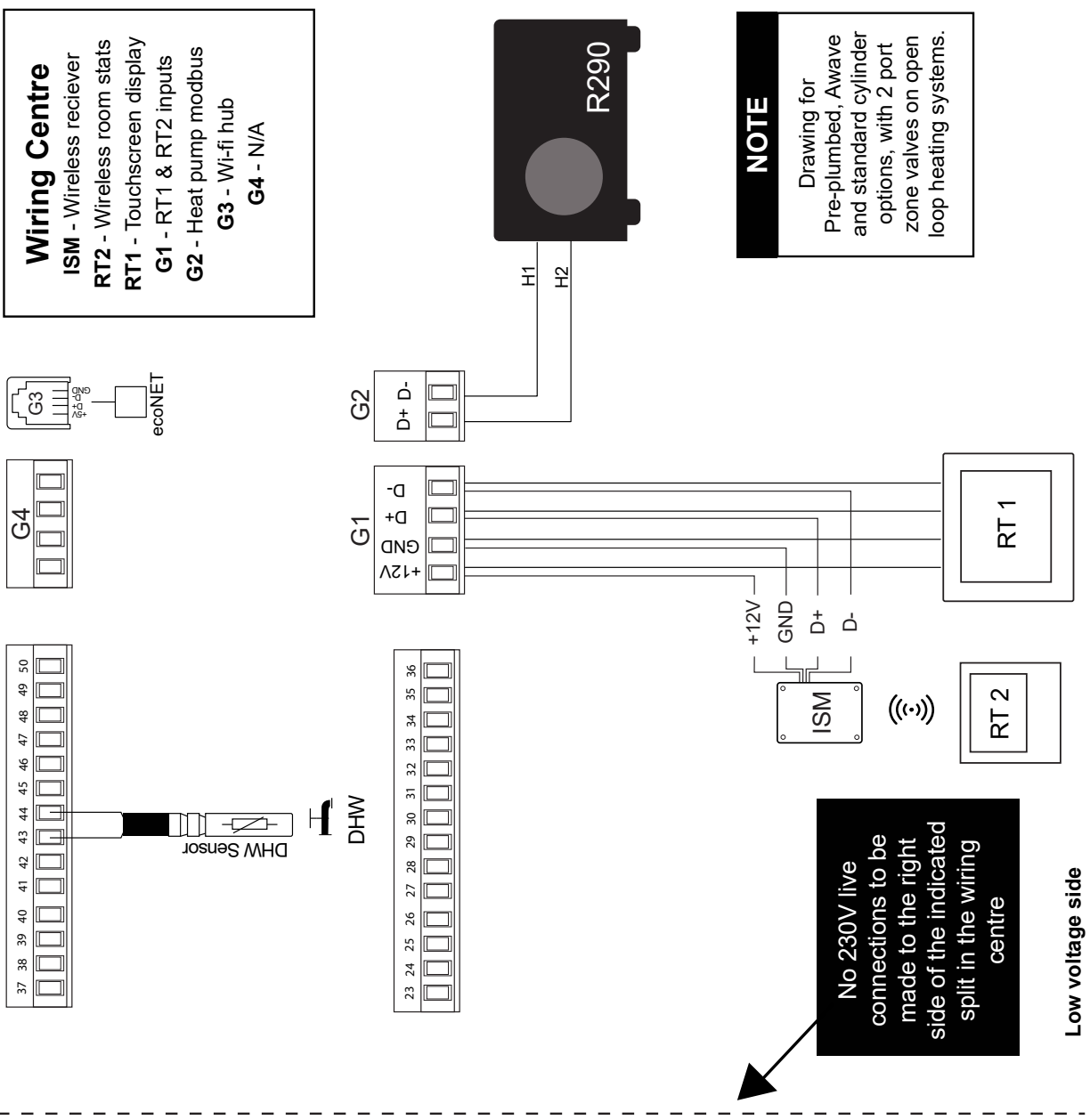

Low voltage side

6.76.3 PREPLUMBED, AWAVE & STANDARD CYLINDER 2-PORT

Wiring Centre
 RT1 - Touchscreen display
 RT3 - 12VDC room stats
 G1 - RT1 & RT3 inputs
 G2 - Heat pump modbus
 G3 - Wi-fi hub
 G4 - N/A

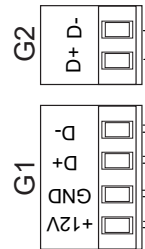
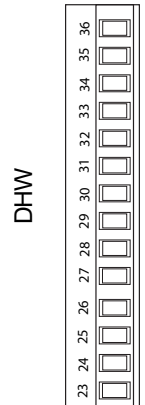
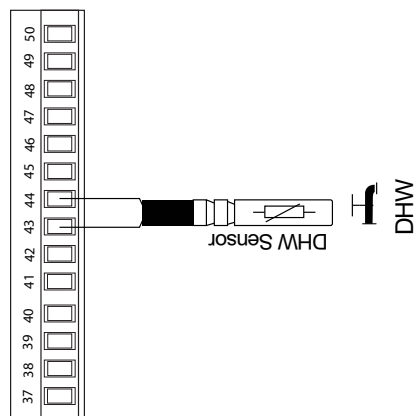
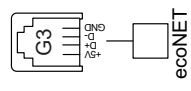

NOTE
 Drawing for Pre-plumbed, Awake and standard cylinder options, with 2 port zone valves on open loop heating systems.

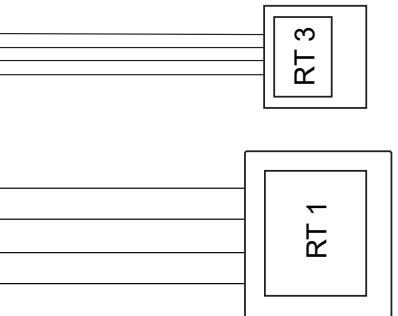

No 230V live connections to be made to the right side of the indicated split in the wiring centre

Low voltage side

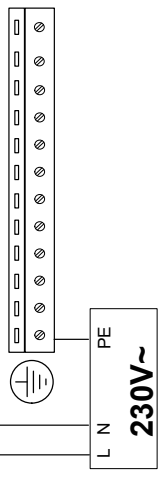
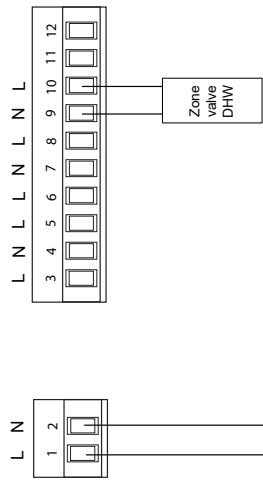
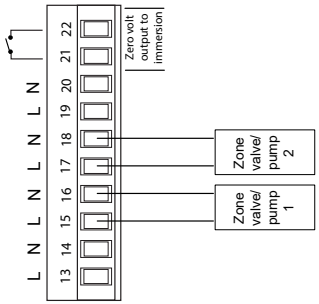

*Zone valve 3 (not supplied with Awake & Preplumbed cylinders)
 Must only be used for non mixed circuits (Radiators)

Mains voltage side - 230V AC

6.7.4 STANDARD CYLINDER SPRING 3-PORT

Wiring Centre
ISM - Wireless receiver
RT2 - Wireless room stats
RT1 - Touchscreen display
RT3 - 12VDC room stats
G1 - RT1, RT2, & RT3 inputs
G2 - Heat pump modbus
G3 - Wi-fi hub
G4 - N/A

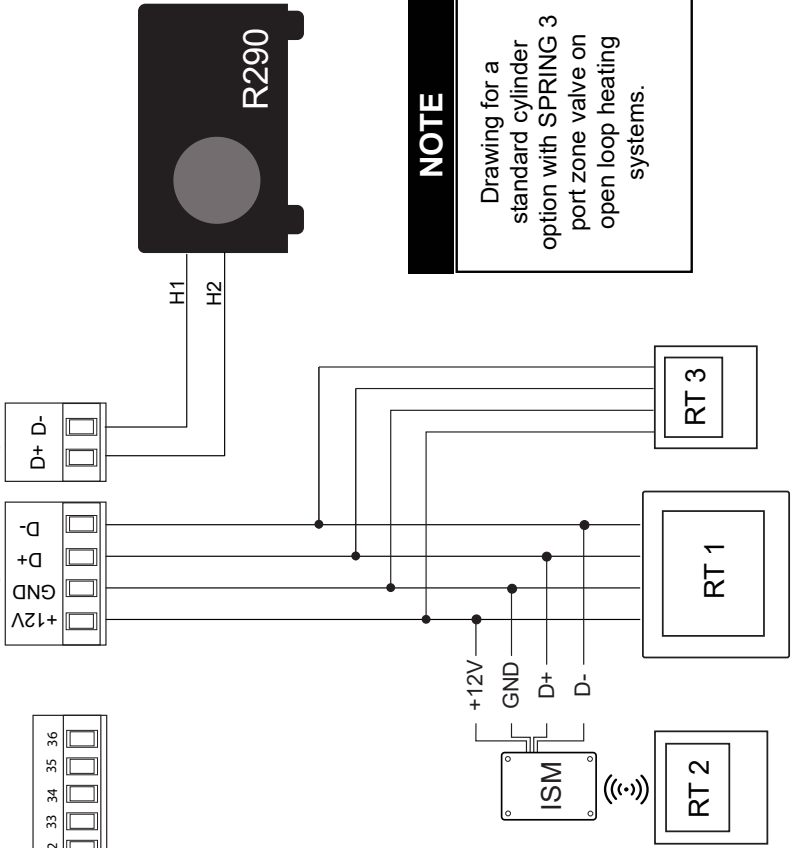
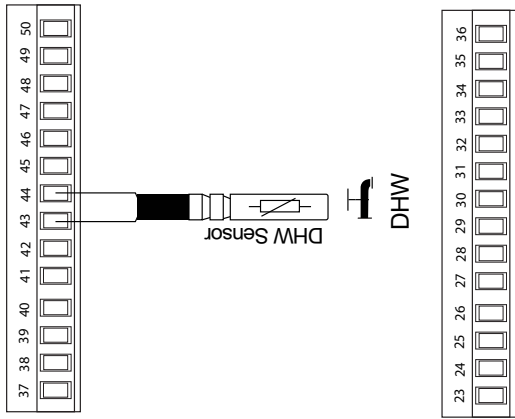
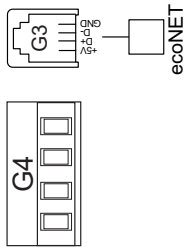

NOTE
 Drawing for a standard cylinder option with SPRING 3 port zone valve on open loop heating systems.

No 230V live connections to be made to the right side of the indicated split in the wiring centre

Low voltage side

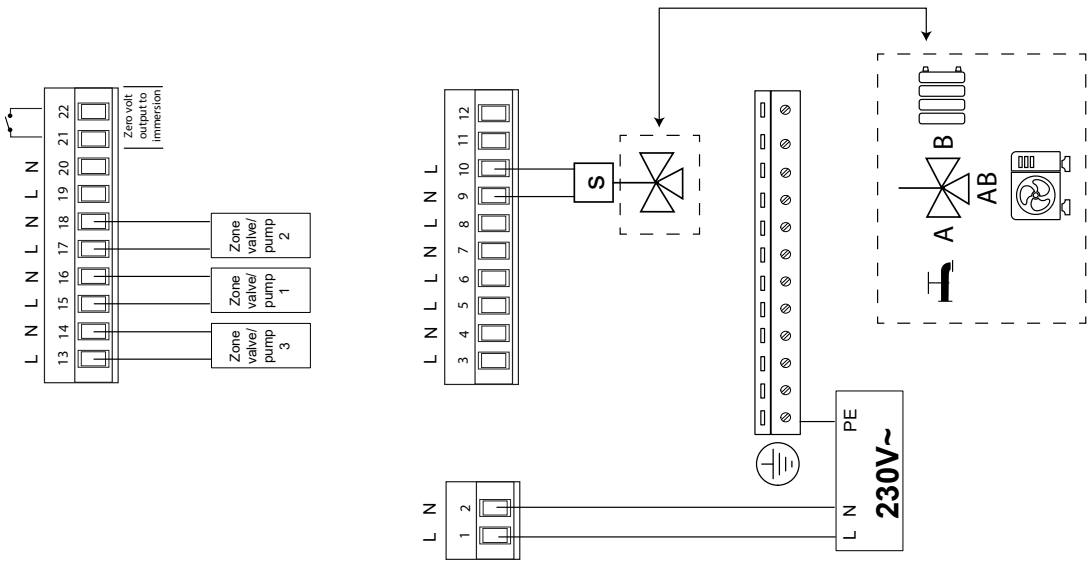

Mains voltage side - 230V AC

6.7.5 STANDARD CYLINDER SPRING 3-PORT

Wiring Centre
 RT1 - Touchscreen display
 RT3 - 12VDC room stats
 G1 - RT1 & RT3 inputs
 G2 - Heat pump modbus
 G3 - Wi-fi hub
 G4 - N/A

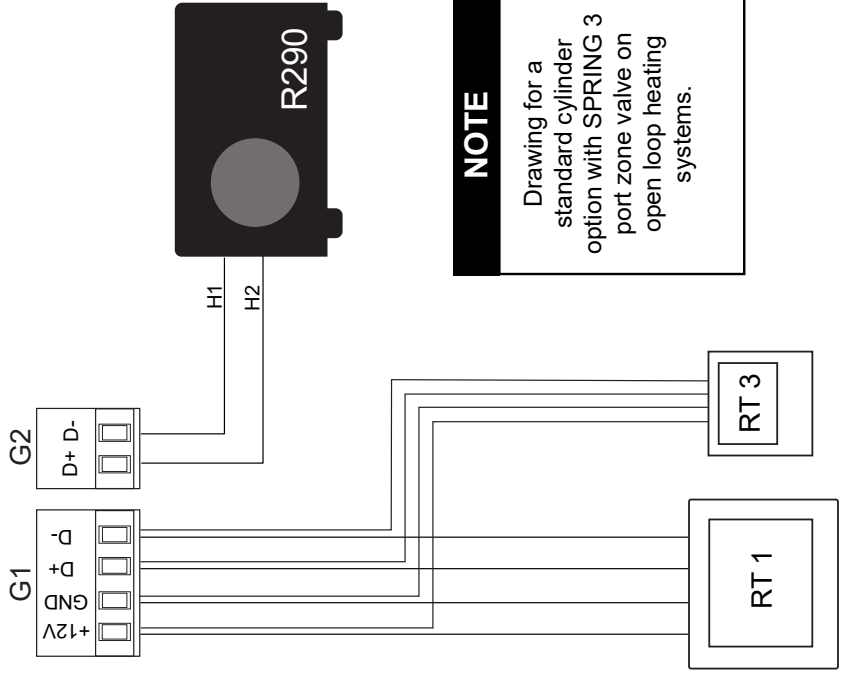
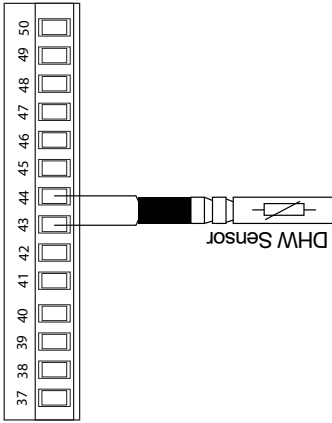
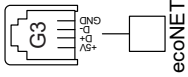

NOTE
 Drawing for a standard cylinder option with SPRING 3 port zone valve on open loop heating systems.

No 230V live connections to be made to the right side of the indicated split in the wiring centre

Low voltage side

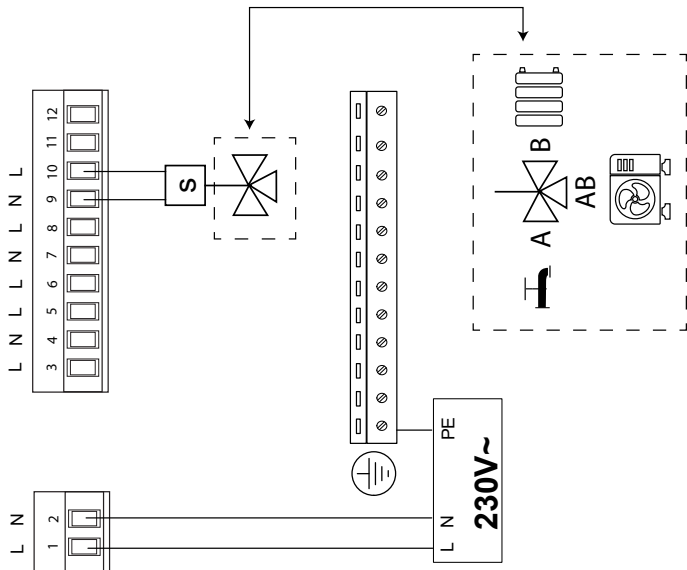
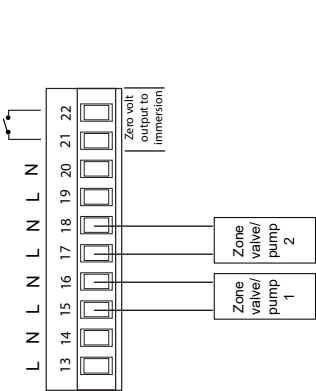

Mains voltage side - 230V AC

6.7.6 STANDARD CYLINDER SPRING 3-PORT

Wiring Centre
ISM - Wireless receiver
RT2 - Wireless room stats
RT1 - Touchscreen display
G1 - RT1 & RT2 inputs
G2 - Heat pump modbus
G3 - Wi-fi hub
G4 - N/A

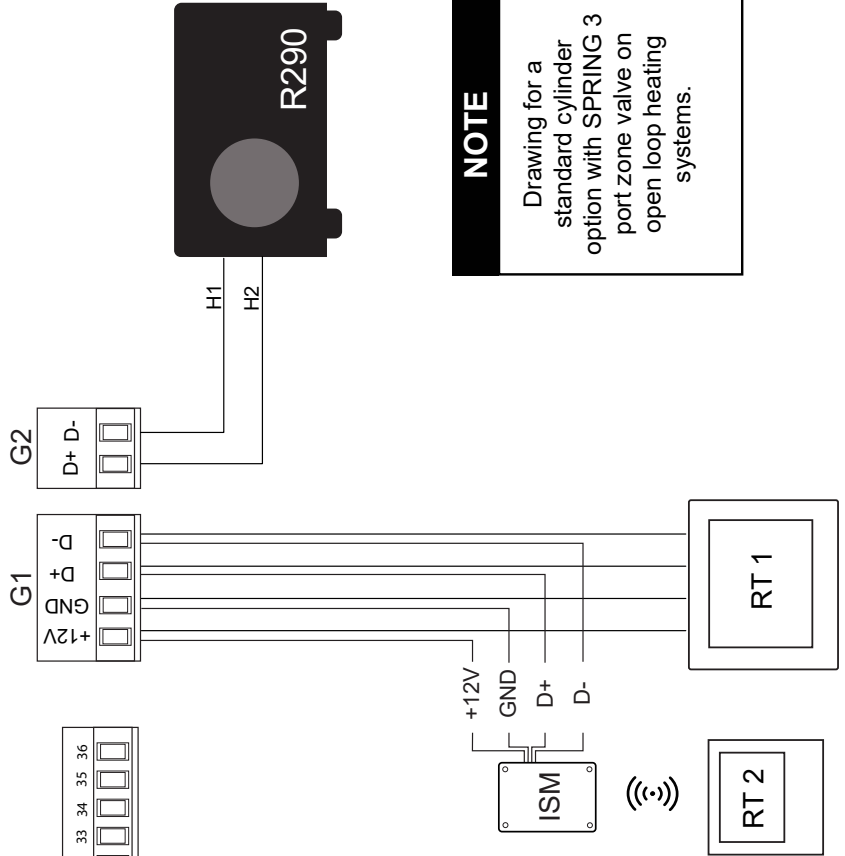
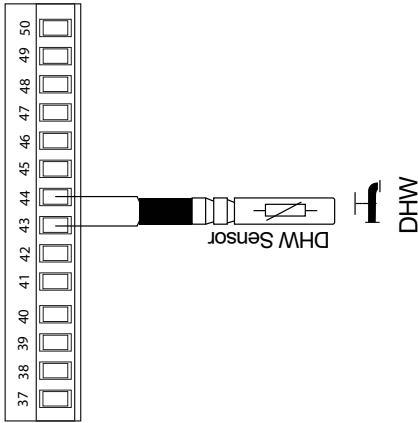
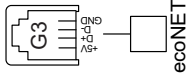

NOTE
 Drawing for a standard cylinder option with SPRING 3 port zone valve on open loop heating systems.

No 230V live connections to be made to the right side of the indicated split in the wiring centre

Low voltage side

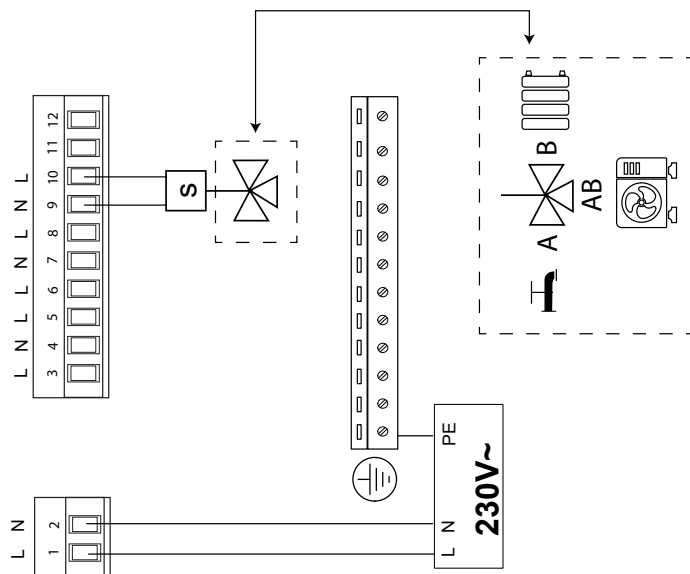
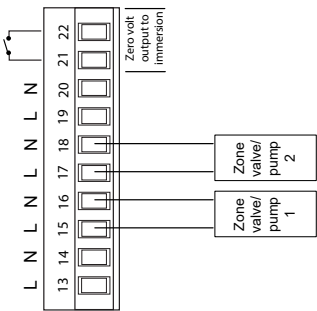

Mains voltage side - 230V AC

6.7.7 STANDARD CYLINDER DRIVEN 3-PORT

Wiring Centre
ISM - Wireless receiver
RT2 - Wireless room stats
RT1 - Touchscreen display
RT3 - 12VDC room stats
G1 - RT1, RT2, & RT3 inputs
G2 - Heat pump modbus
G3 - Wi-fi hub
G4 - N/A

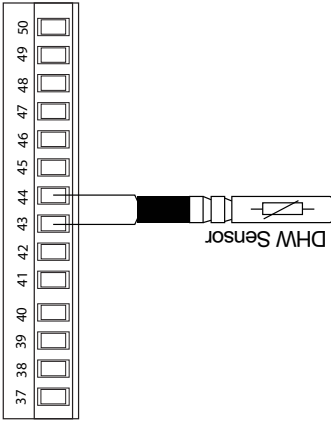
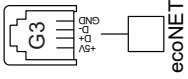

DHW

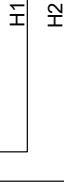
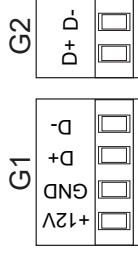
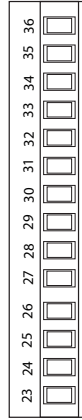

NOTE
 Drawing for a standard cylinder option with DRIVEN 3 port zone valve on open loop heating systems, P/L from 1 to valve actuator

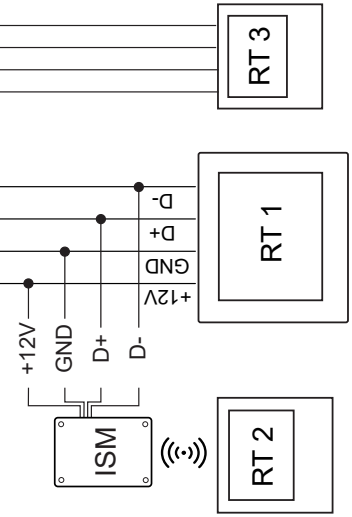

No 230V live connections to be made to the right side of the indicated split in the wiring centre

Low voltage side

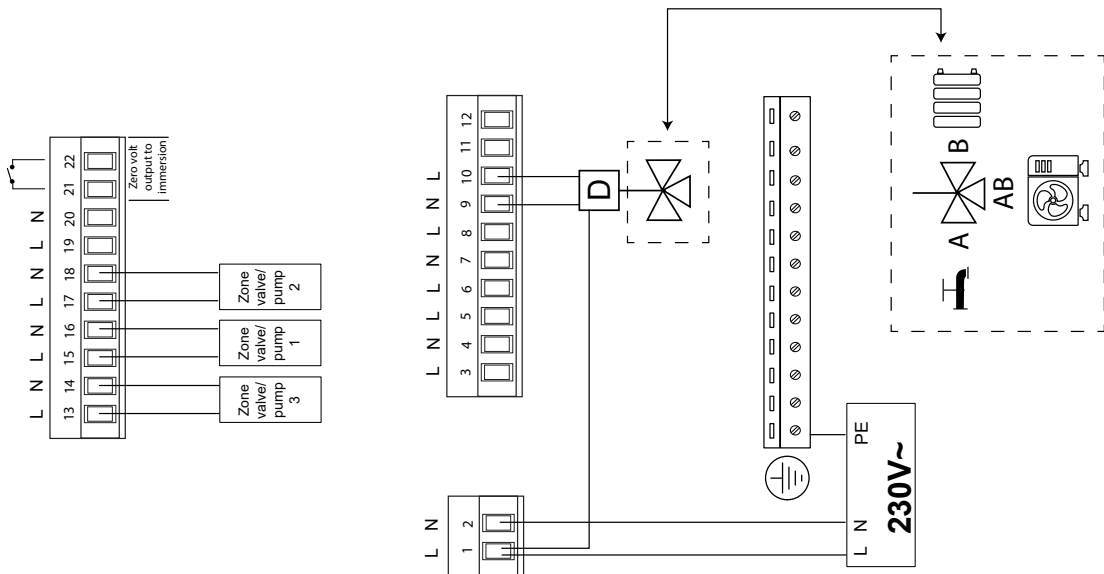

Mains voltage side - 230V AC

6.7.8 STANDARD CYLINDER DRIVEN 3-PORT

Wiring Centre
 RT1 - Touchscreen display
 RT3 - 12VDC room stats
 G1 - RT1 & RT3 inputs
 G2 - Heat pump modbus
 G3 - Wi-fi hub
 G4 - N/A

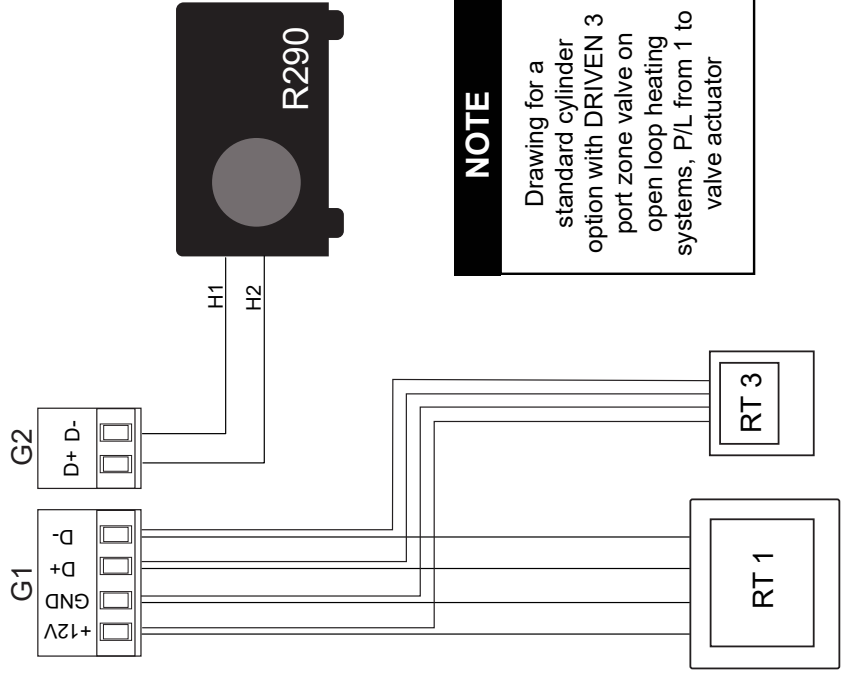
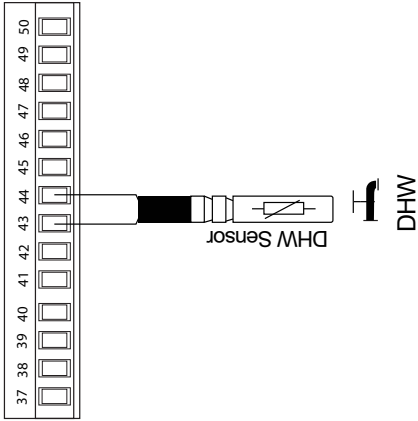
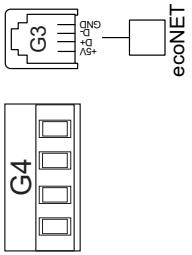

NOTE
 Drawing for a standard cylinder option with DRIVEN 3 port zone valve on open loop heating systems, P/L from 1 to valve actuator

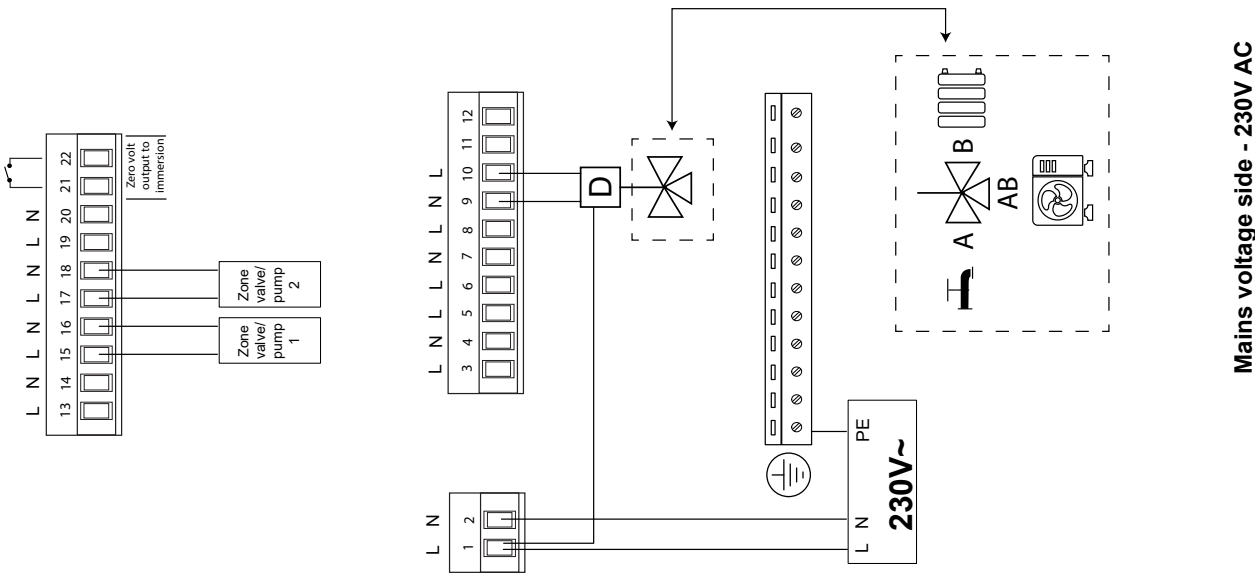

No 230V live connections to be made to the right side of the indicated split in the wiring centre

Low voltage side

Mains voltage side - 230V AC

6.7.9 STANDARD CYLINDER DRIVEN 3-PORT

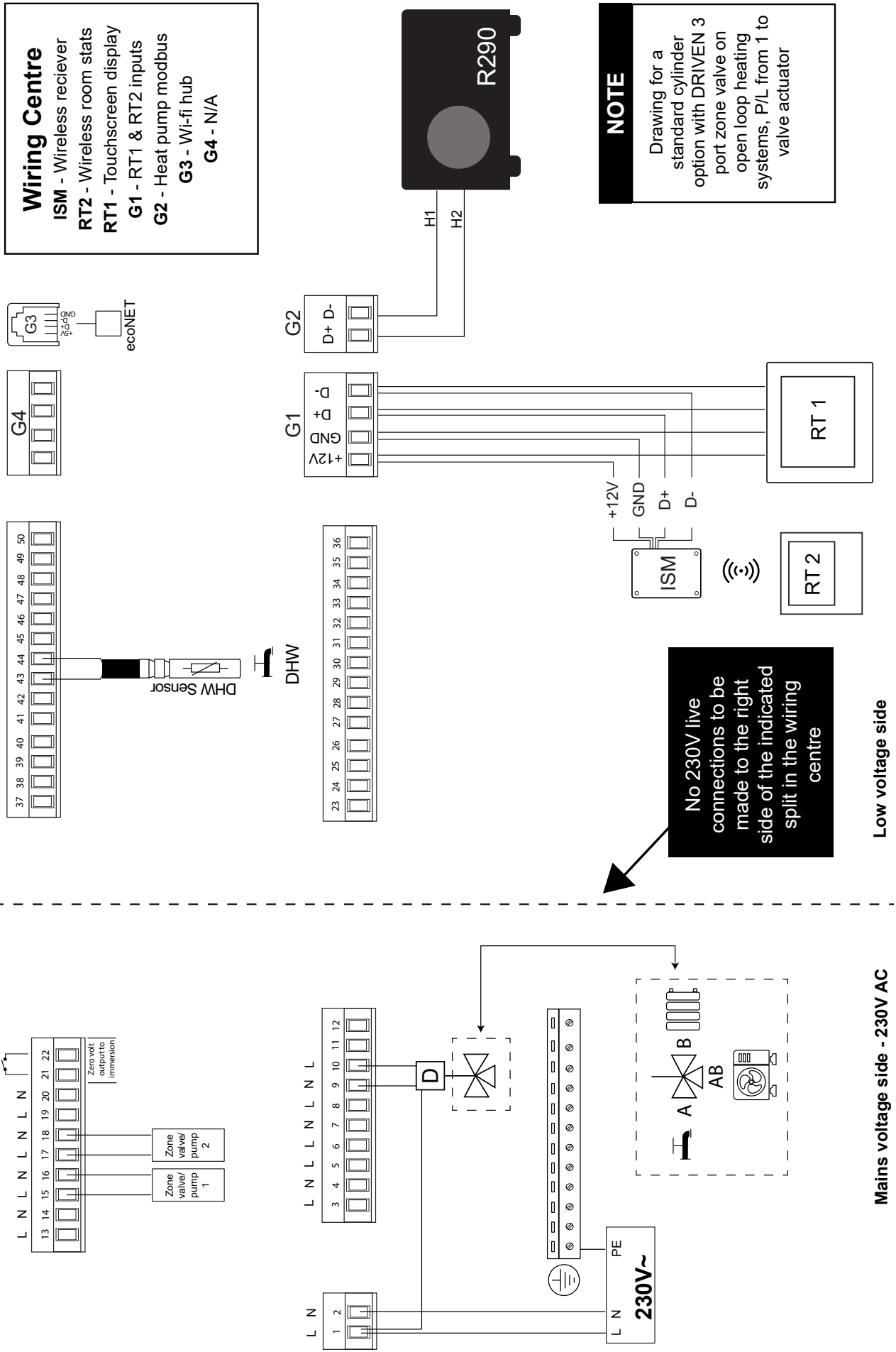

Wiring Centre
 ISM - Wireless receiver
 RT2 - Wireless room stats
 RT1 - Touchscreen display
 G1 - RT1 & RT2 inputs
 G2 - Heat pump modbus
 G3 - Wi-fi hub
 G4 - N/A

NOTE
 Drawing for a standard cylinder option with DRIVEN 3 port zone valve on open loop heating systems, P/L from 1 to valve actuator

No 230V live connections to be made to the right side of the indicated split in the wiring centre

Low voltage side

Mains voltage side - 230V AC

6.7.10 NON GRANT UFH CONTROLS

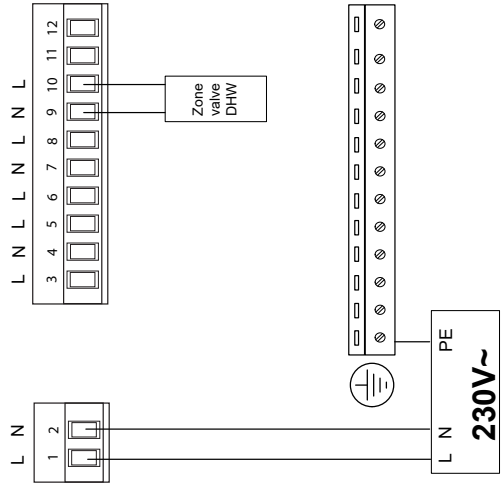

Mains voltage side - 230V AC

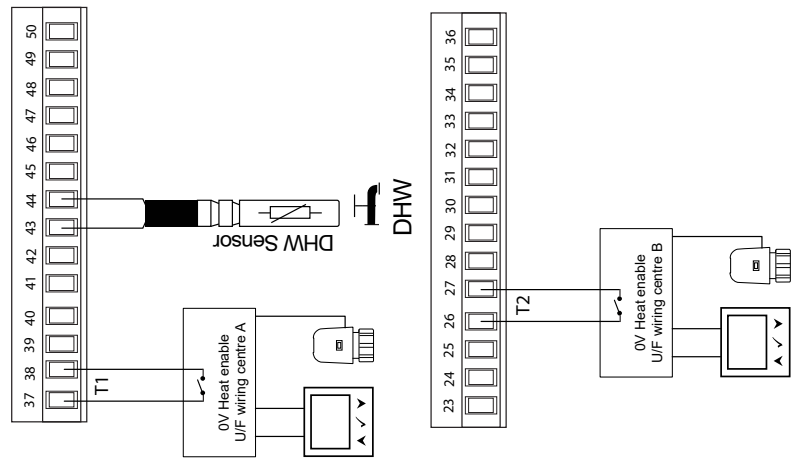

No 230V live connections to be made to the right side of the indicated split in the wiring centre

Low voltage side

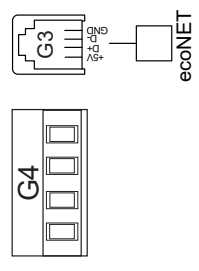

Wiring Centre
 RT1 - Touchscreen display
 G1 - RT1 input
 G2 - Heat pump modbus
 G3 - Wi-fi hub
 G4 - N/A

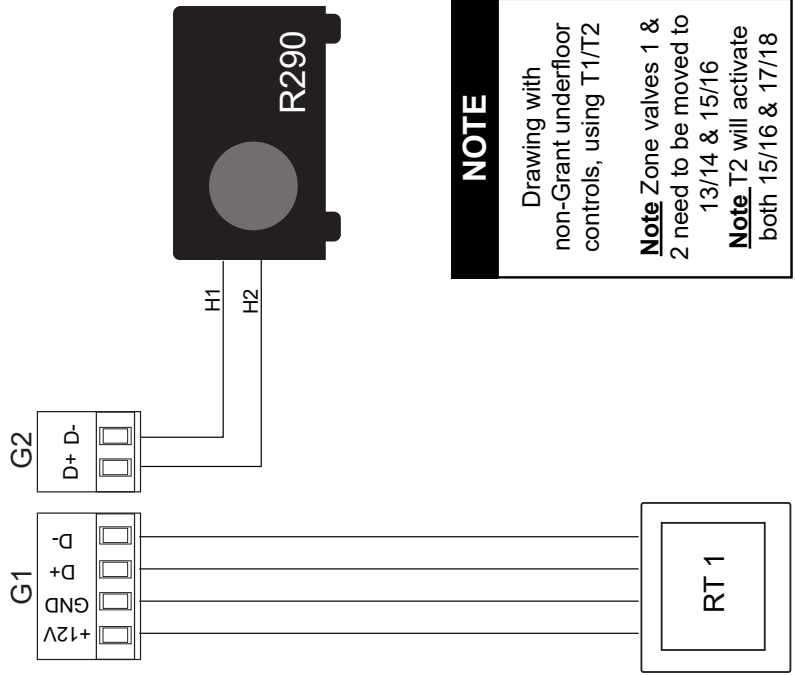

NOTE
 Drawing with non-Grant underfloor controls, using T1/T2
Note Zone valves 1 & 2 need to be moved to 13/14 & 15/16
Note T2 will activate both 15/16 & 17/18

7 SMART CONTROLLER (SEE SMART CONTROLLER MANUAL)

7.1 GRANT AERONA SMART CONTROLLER

The Grant Aerona Smart Controller is used to:

- Switch the heat pump on and off.
- Display selected circuit actual & target temperatures.
- Display outdoor temperature.
- Perform heat curve adjustments to flow temperatures based on ambient external air temperatures
- Manage space heating, DHW and Heat pump schedules.
- Manage Legionella protection scheduling.
- Access and check/adjust controller parameters.
- Access and check/adjust the heat pump control parameters
- Provide web based monitoring and control functionality.

The Grant Aerona Smart Controller will also display any fault error codes should there be a fault condition on both the supplied touchscreen display and any installed additional thermostats.

It can also be used to view the heat pump operating conditions at any point in time using the both the touchscreen display and the web based portal, if connected via ecoNET24 external services.

For more information refer to your supplied manual:

- DOC 0034 - smart heat pump system controller
- DOC 0033 - for systems with Grant Smart standard and pre-plumbed cylinder.

7.2 INSTALLATION REQUIREMENTS

For information relating to the installation requirements of the Grant Aerona Smart controller, refer to your supplied manual:

- DOC 0034 - smart heat pump system controller
- DOC 0033 - for systems with Grant Smart standard and pre-plumbed cylinder

7.3 CONNECTING THE SMART CONTROLLER TO THE HEAT PUMP

1. Isolate the mains power supply for the heat pump from the power source.
Do not connect the Smart controller modbus cable with the power on.
2. Remove the side panel and the Hydraulic PCB housing panel. Refer to Section 6.1.1
3. Feed the modbus cable through a low voltage hole in the R290 housing and Hydraulic PCB housing.
4. Strip a sufficient amount off the end of the cable to connection to the terminal on the Hydraulic PCB.
5. Connect the 2 core modbus cable to the H1(D-) and H2(D+) terminals on the Hydraulic PCB board. Refer to Figure 7-1.

! NOTE !

Make note of which wire colour is connected to which terminal. The modbus connection will need polarities matched at the heat pump and smart controller.

6. Securely fasten the modbus cable with the cable clamp fitted
7. Refit the Hydraulic PCB housing panel & side panel to the heat pump.
8. Connect the modbus cable to the Grant Aerona Smart controller to the G2 socket.

7.4 SMART CONTROLLER OPERATION

For information relating to the operation of the Grant Aerona Smart controller, refer to your supplied manual:

- DOC 0034 - smart heat pump system controller
- DOC 0033 - for systems with Grant Smart standard and pre-plumbed cylinder.

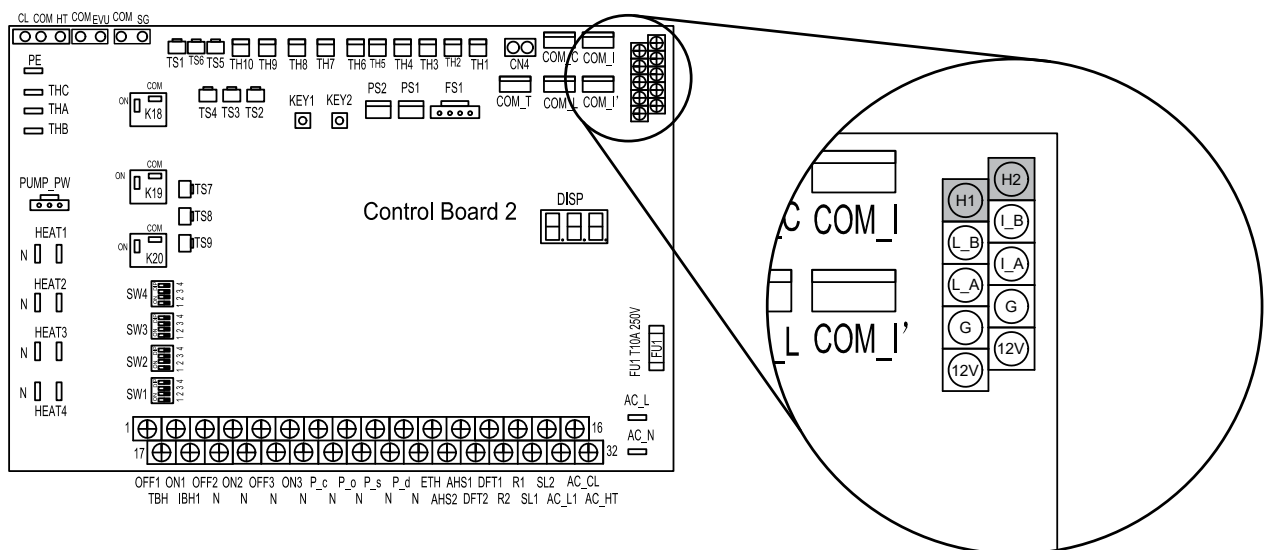

Figure 7-1: Hydraulic PCB U19 communication ports

8 OPERATION

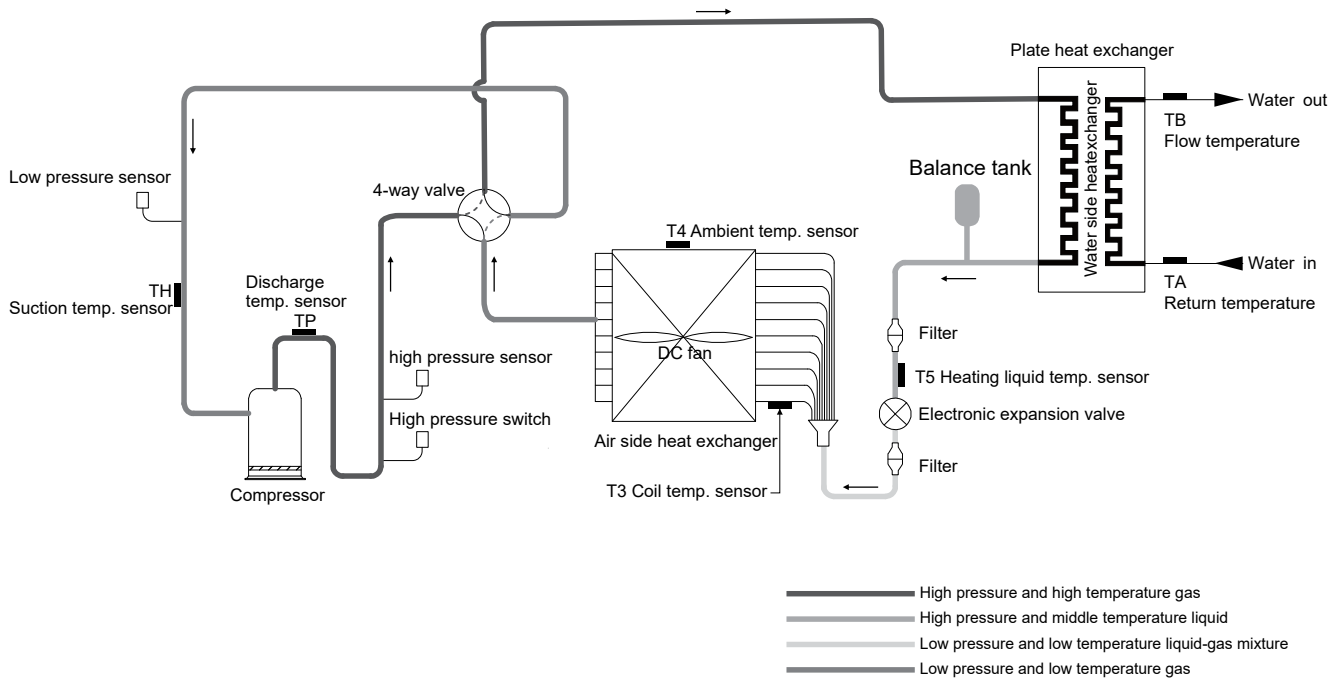

Figure 8-1: Refrigerant flow - Heating

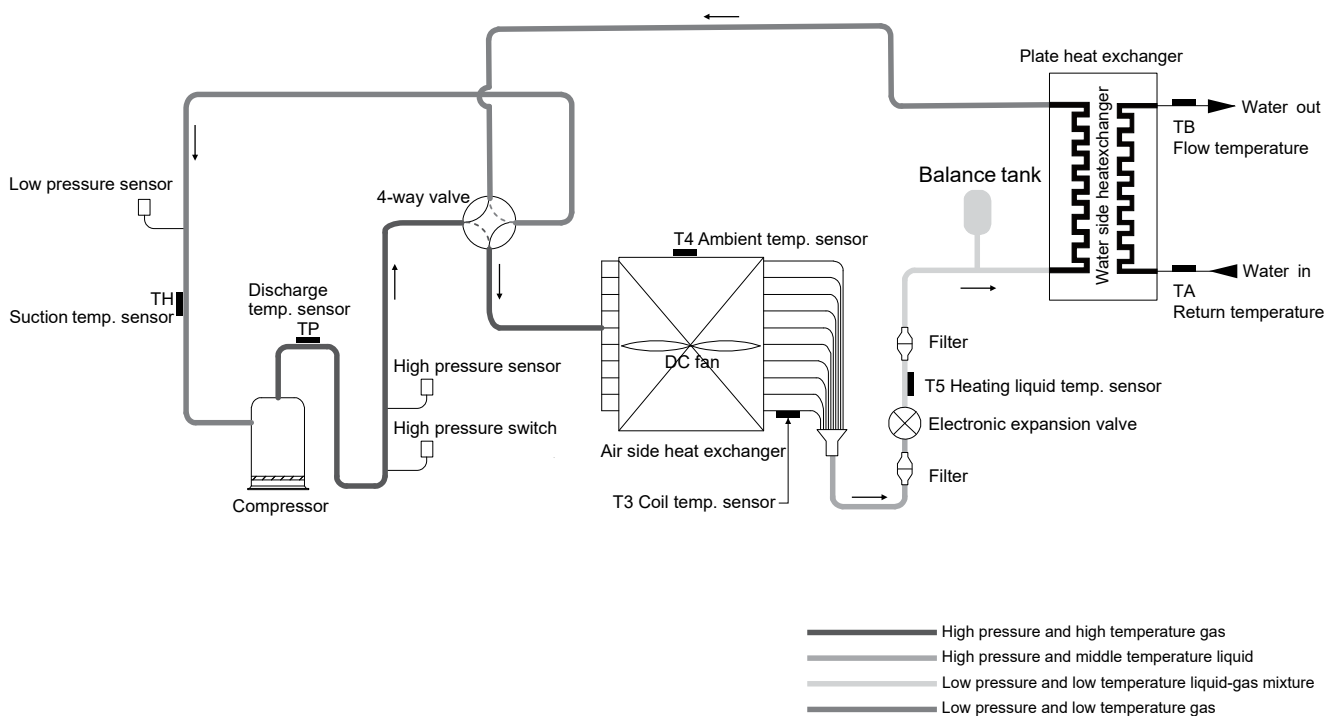

Figure 8-2: Refrigerant flow - Defrost

9 COMMISSIONING

9.1 SYSTEM SETUP

With the desired system installed and completed, commissioning will be required.

! CAUTION !

It is important that all information in this section is read sequentially by the installer and that the system is configured as applicable.

9.1.1 PRE-OPERATION CHECKS

Checks before initial start-up:

Ensure the power supply is isolated before making any connections.

After the installation of the unit, check the following before switching on the circuit breaker:

- **Installation wiring:** Make sure that the installation wiring between the local consumer unit, isolator, heat pump, controls and valves (when applicable), domestic hot water cylinder, and backup immersion heater, have been connected following the instructions described in section 6 in accordance with the IS-10101 NREI edition 5 wiring regulations.
- **Fuses, circuit breakers, or protection devices:** Check that the fuses or the locally installed protection devices are of the size and type specified in section 6. Make sure that no fuses or protection devices have been bypassed.
- **Backup heater circuit breaker:** Do not forget to turn on the backup heater circuit breaker (applies only to units with optional domestic hot water cylinder installed).
- **Ground wiring:** Make sure that the earth wires have been connected properly and that the earth terminals are tightened.
- **Internal wiring:** Visually check the switch box for loose connections or damaged electrical components.
- **Mounting:** Check that the heat pump is properly mounted to avoid abnormal noises and vibrations when starting up the heat pump.
- **Damaged equipment:** Check the inside of the heat pump for damaged components or squeezed pipes.
- **Refrigerant leak:** Check the inside of the unit for refrigerant leakage with appropriate equipment by a component technician.
- **Power supply voltage:** Check the power supply voltage from the local consumer unit. The voltage must correspond to the voltage on the identification label of the unit.
- **Automatic air vent:** Make sure the cap on the automatic air vent is open (at least 2 turns).
- **Isolation valves:** Make sure that both the isolation valves are fully open.

9.1.2 TURNING THE HEAT PUMP ON

The installed isolator is the primary switch and as such, the heat pump will start once the isolator has been set to 'ON'.

9.1.3 TURNING THE SMART CONTROLLER ON

The power switch for the Grant Aerona Smart controller is located on the left side of the wiring centre, when facing it from the front. For information relating to the powering ON of the Grant Aerona Smart Controller, refer to your supplied manual:

- DOC 0034 - smart heat pump system controller
- DOC 0033 - for systems with Grant Smart standard and pre-plumbed cylinder

9.1.4 INITIAL START-UP AT LOW OUTDOOR AMBIENT TEMPERATURE

For under floor heating systems, during initial start-up and when water temperature is low, it is important that the water is heated gradually. **Failure to do so may result in concrete floors cracking due to rapid temperature change.**

9.1.5 FAULT ON INITIAL SWITCH ON

If nothing is displayed on the touch screen display, it is necessary to check for any of the following problems:

- Wire Disconnection or wiring error (between the heat pump, wiring centre and touch screen display)
- The fuse on the hydraulic module PCB may have failed
- The fuse on the Smart Controller wiring centre PCB may have failed

If the touch screen display shows a 'P01' error code, there is a possibility that there is air in the system, or the water level in the system is less than the required minimum.

If the touch screen display shows a 'E01' error code, check the connections between the wiring centre and heat pump.

Refer to section 11 for details on error codes.

9.2 SYSTEM CONFIGURATION

The Grant Aerona Smart Controller integrated system configuration creator will aid with the setup of the space heating and DHW system within the software of the touchscreen display.

The steps in the configuration creator should reflect the system you have designed and electrically connected to the wiring centre.

For information relating to System configuration on of the Grant Aerona Smart controller, refer to your supplied manual:

- DOC 0034 - smart heat pump system controller
- DOC 0033 - for systems with Grant Smart standard and pre-plumbed cylinder.

9.2.1 COMMISSIONING CHECKLIST

The Pre-commissioning checklist must have all sections completed and returned to Grant. The supplied manual for the Smart controller offers an easy to follow commissioning checklist for the installer. In addition, the section includes suggested circuit settings based on concept drawings offered by Grant (Refer to Online resources section for links) and common heating circuits required.

For information relating to the commissioning on of the Grant Aerona Smart controller, refer to your supplied manual:

- DOC 0034 - smart heat pump system controller
- DOC 0033 - for systems with Grant Smart standard and pre-plumbed cylinder.

9.2.2 WEATHER COMPENSATION

For information relating to Weather compensation on the Grant Aerona Smart controller, refer to your supplied manual:

- DOC 0034 - smart heat pump system controller
- DOC 0033 - for systems with Grant Smart standard and pre-plumbed cylinder

9.3 SETTINGS

The parameters to control the heat pump and the installed space heating and DHW are managed via the touchscreen display. There are multiple levels of access which manage various elements:

- User settings
- System settings
- Heat pump parameters

9.3.1 USER SETTINGS

For information relating to the User settings menu on of the Grant Aerona Smart controller, refer to your supplied manual:

- DOC 0034 - smart heat pump system controller

- DOC 0033 - for systems with Grant Smart standard and pre-plumbed cylinder.

9.3.2 SYSTEM SETTINGS

For information relating to the System settings menu on of the Grant Aerona Smart controller, refer to your supplied manual:

- DOC 0034 - smart heat pump system controller
- DOC 0033 - for systems with Grant Smart standard and pre-plumbed cylinder.

9.3.3 HEAT PUMP PARAMETERS

For information relating to the Heat pump parameters menu on of the Grant Aerona Smart controller, refer to your supplied manual:

- DOC 0034 - smart heat pump system controller
- DOC 0033 - for systems with Grant Smart standard and pre-plumbed cylinder

9.4 TEMPERATURE CONTROL

The Grant Aerona Smart Controller will alter the flow from the heat pump based on the highest demand of the circuits active at that point.

Table 9-1: Smart controller Flow example

Circuit	Flow temperature	Setting (°C)
1 - Radiators	C1 (calculative)	48
2 - Underfloor	C2 (calculative)	31
DHW	User set target	60

Refer to Table 9-1 for example below:

- Circuit 2 is active with the Smart controller managing a target flow temperature target of 31°C.
- The installed thermostat for circuit 1 creates a demand for the circuit (target air temperature is below hysteresis value for the circuit).
- The Smart controller adjusts the heat pump target flow temperature to the 48°C temperature.
- Active temperature management for circuit 2 will be required in either the form of a 3-port actuator mixer valve or thermostatic mixing valve to keep the temperature at the required level for the underfloor circuit.
- The DHW schedule activates whilst a heat demand is active. The Smart controller will cut heating circuits and open the DHW circuit.
- The Smart controller will modify target flow temperature to 60°C until the DHW cylinder has reached target user set temperature.
- Smart controller will reactivate the heating circuits and heat pump target flow temperature is modulated down to the next highest temperature demand.
- Should the cylinder fall below hysteresis value set within its scheduled 'ON' period, the Smart controller will divert heat back to the cylinder, cutting heating circuits and adjust the target flow temperature accordingly.

9.5 FLOW

Grant Aerona R290 heat pumps are supplied with a PWM circulating pump. The pump output is modulated based on demand.

The flow switch within the heat pump monitors a minimum flow rate is present when the heat pump is active. If not, the flow switch will not be activated and the heat pump will shut down.

Refer to Appendix A for further information on the PWM pump.

9.6 BALANCING THE PRIMARY CIRCUIT

With the heat pump installed as described in these installation instructions, any hot water cylinders connected to the system filled with water and the primary circuit filled and vented (refer to Section 4.2); the primary circuit can be balanced.

To balance the primary circuit:

1. Access the automatic system bypass valve, if fitted, e.g. on an S-plan system using 2-port zone valves.
Ensure the automatic bypass valve is fully closed.

2. For systems fitted with one or more Thermostatic Radiator Valves (TRVs) - Fully open all TRVs fitted to radiators on the system. In warmer temperatures climates it may be necessary to slacken the TRV heads off or temporarily remove them, in order to prevent the ambient temperature closing the TRVs down.
For systems with one or more radiators without TRVs, fully open all manual radiator shut-off valves.
3. Fully open all radiator lockshield valves.
4. Turn the heat pump on, operate the system in space heating mode and allow the system to start heating up.
5. With the system flow temperature approaching its set value, check the temperature difference between the flow and return pipes connected to each heat emitter on the system, starting with the radiator emitter closest furthest from to the heat pump.
In the case of a Grant Aerona R290 heat pump, this temperature difference should be approximately 5 to 8K (or 5 to 8°C).
6. Adjust the lockshield valve on the radiator to until the required temperature difference is achieved. In instances where this temperature difference is too low, close the appropriate radiator lockshield valve fully and open no more than half a turn at a time to until the required temperature difference is reached.

Repeat this process for the next radiator in the circuit until the required desired flow/return temperature difference has been achieved for all heat emitters on the system.

It may be necessary to repeat this cycle starting again with the radiator furthest from the heat pump until no further adjustment is required. This may require the adjustment of each radiator several times.

! NOTE !

Throughout the process of balancing the system, it is important to ensure that the heat pump is continuously operating to provide heat to the space heating circuit.

7. Turn the heating demands off and allow the system to cool.
8. While the system is cooling and with the automatic bypass valve still fully closed, re-fit or tighten any TRV heads that were removed or slackened. Then fully close all TRVs on the system.
For systems with one or more radiators without TRVs, fully close all manual radiator shut-off valves.
9. With all TRVs and/or manual shut-off valves on the system fully closed, turn the heat pump on and operate the system in space heating mode. Allow the system to reach operating temperature.
10. Open the automatic bypass valve until you detect that water is just starting to flow through it.
11. Ensure the heat pump is operating at the chosen flow temperature without modulating down.
12. If the heat pump is modulating down, open the automatic bypass valve slightly until a situation is achieved where all TRVs/manual shut-off valves on the system are fully closed and the heat pump continues to run at the chosen operating temperature.
13. Leave the automatic bypass valve in this position, open all TRVs/manual shut-off valves fully and allow the system to run according to the householder's requirements.

The primary circuit has now been balanced and the automatic bypass valve has been set.

! NOTE !

Ensure the isolation valves remain open after commissioning

10 SERVICING

10.1 SAFETY

Prior to performing any annual service or repair work on a Grant Aerona R290 heat pump the following guidance must be followed:

1. Create a safe working area

Set up a barrier at least 1m around the heat pump within which only those persons working on the heat pumps are permitted access. All maintenance staff and others working in this safe working area shall be instructed on the nature of work being carried out. Working in confined spaces shall be avoided.

2. Work procedure

Works shall be undertaken under a controlled procedure to minimise the risk of a flammable gas or vapour being present and to ensure that the risk of ignition is minimised within the safe working area while the work is being performed.

3. Checking for presence of refrigerant

The heat pump and the safe working area shall be checked with an appropriate refrigerant detector prior to and during work, to ensure the technician is aware of potentially flammable atmospheres. Ensure that the leak detection equipment being used is suitable for use with flammable refrigerants, i.e. no sparking, adequately sealed or intrinsically safe and it can detect R290 refrigerant.

4. Presence of fire extinguisher

If any hot works are to be conducted on the refrigerant circuit of the heat pump or any associated parts, appropriate fire extinguishing equipment shall be available to hand. Have a dry powder or CO2 fire extinguisher adjacent to the refrigerant charging area.

5. No ignition sources

No person carrying out work in relation to the refrigerant circuit of the heat pump which involves exposing any pipe work that contains or has contained flammable refrigerant, shall use any sources of ignition in such a manner that it may lead to the risk of fire or explosion. All possible ignition sources, including smoking, should be kept outside of the safe working area repairing, removing and disposal, during which flammable refrigerant can possibly be released to the surrounding space. Prior to work taking place, the area around the equipment is to be surveyed to make sure that there are no flammable hazards or ignition risks. **'NO SMOKING'** signs shall be displayed.

6. Ventilated area

Ensure that the safe working area is in the open or that it is adequately ventilated before breaking into the refrigerant circuit or conducting any hot works. A degree of ventilation shall continue during the period that the work is carried out. The ventilation should safely disperse any released refrigerant and preferably expel it externally into the atmosphere.

7. Checks to the refrigerant circuit and equipment

Where electrical components are being changed, they shall be fit for the purpose and to the correct specification. The manufacturers maintenance and service guidelines shall be followed at all times. If in doubt consult the Grant technical department for assistance.

The following checks shall be applied to installations using flammable refrigerants. Checks to the refrigeration equipment.

- As an indirect refrigerating circuit is being used, the secondary (water) circuit should be checked for the presence of refrigerant presence of refrigerant, using suitable test equipment by a suitably qualified person.
- Marking on the equipment continues to be visible and legible. Marking and signs that are illegible should be corrected.
- The heat pump is installed such that the refrigerant circuit pipe and components are located in a position where they are unlikely to be exposed to any substance which may corrode them

8. Checks to electrical devices

Repair and maintenance to electrical components shall include initial safety checks and component inspection procedures. If a fault exists that could compromise safety, then no electrical supply shall be connected to the circuit until it is satisfactorily dealt with. If the fault cannot be corrected immediately but it is necessary to continue operation, an adequate temporary solution shall be used. This shall be reported to the owner of the equipment so all parties are advised.

Initial safety checks shall include:

- That capacitors are discharged: this shall be done in a safe manner to avoid possibility of sparking.
- That there no live electrical components and wiring exposed while charging, recovering or purging the system.
- That there is continuity of earth bonding.

9. Repairs to sealed components

During repairs to sealed components, all electrical supplies shall be disconnected from the heat pump and controls being worked upon prior to any removal of sealed covers, etc. If it is absolutely necessary to have an electrical supply to equipment during servicing, then a permanently operating form of leak detection shall be located at the most critical point to warn of a potentially hazardous situation.

Particular attention shall be paid to the following to ensure that by working on electrical components, the casing is not altered in such a way that the level of protection is affected. This shall include damage to cables, excessive number of connections, terminals not made to original specification, damage to seals, incorrect fitting of glands, etc.

- Ensure that apparatus is mounted securely.
- Ensure that seals or sealing materials have not degraded such that they no longer serve the purpose of preventing the ingress of flammable atmospheres. Replacement parts shall be in accordance with the manufacturers specifications.

! CAUTION !

The use of silicon sealant may inhibit the effectiveness of some types of leak detection equipment.

10. Cabling

Check that cabling will not be subject to wear, corrosion, excessive pressure, vibration, sharp edges or any other adverse environmental effects. The check shall also take account of the effects of ageing or continual vibration from sources such as compressors or fans.

11. Detection of flammable refrigerants

Under no circumstances shall potential sources of ignition be used for the detection of refrigerant leaks. A halide torch (or any other detector using a naked flame) must not be used.

12. Leak detection methods

The following leak detection methods are deemed acceptable for systems containing flammable refrigerants.

- Electronic leak detectors shall be used to detect flammable refrigerants, but the sensitivity may not be adequate, or may need re-calibration. (Detection equipment shall be calibrated in a refrigerant-free area.) Ensure that the detector is not a potential source of ignition and is suitable for the refrigerant.
- Leak detection equipment shall be set at a percentage of the LFL of the refrigerant and shall be calibrated to the refrigerant employed and the appropriate percentage of gas (25% maximum) is confirmed.

- Leak detection fluids are suitable for use with most refrigerants but the use of detergents containing chlorine shall be avoided as the chlorine may react with the refrigerant and corrode the copper pipework.
- If a leak is suspected, all naked flames shall be removed or extinguished.
- If a leakage of refrigerant is found which requires brazing, all of the refrigerant shall be recovered from the system, or isolated (by means of shut off valves) in a part of the system remote from the leak.
- Oxygen Free Nitrogen (OFN) shall then be purged through the system both before and during the brazing process.

13. Removal and evacuation

When breaking into the refrigerant circuit to make repairs or for any other purpose conventional procedures shall be used. However, it is important that best practice is followed since flammability is a vital consideration.

All equipment used must be rated for use with A3 refrigerants.

The following procedure shall be adhered to:

- Remove refrigerant
- Purge the circuit with inert gas
- Evacuate
- Purge again with inert gas
- Open the circuit by cutting or brazing.

The refrigerant charge shall be recovered into the correct recovery cylinders. The system shall be flushed with OFN to render the unit safe. This process may need to be repeated several times.

Compressed air or oxygen shall not be used for this task.

Flushing shall be achieved by breaking the vacuum in the system with OFN and continuing to fill until the working pressure is achieved, then venting to atmosphere, and finally pulling down to a vacuum. This process shall be repeated until no refrigerant is within the system.

When the final OFN charge is used, the system shall be vented down to atmospheric pressure to enable work to take place. This operation is absolutely vital if brazing operations on the pipework are to take place.

Ensure that the outlet for the vacuum pump is not close to any ignition sources and there is ventilation available.

14. Charging procedures

In addition to conventional charging procedures, the following requirements shall be followed:

- Ensure that contamination of different refrigerants does not occur when using charging equipment. Hoses or lines shall be as short as possible to minimize the amount of refrigerant contained in them.
- Cylinders shall be kept upright.
- Ensure that the refrigeration system is earthed prior to charging the system with refrigerant.
- Label the system when charging is complete (if not already).
- Extreme care shall be taken not to overfill the refrigeration system.

Prior to recharging the system it shall be pressure tested with OFN. The system shall be leak tested on completion of charging but prior to commissioning. A follow up leak test shall be carried out prior to leaving the site.

10.2 SERVICING & MAINTENANCE PROCEDURE

Grant Aeron R290 heat pumps require only the minimum of routine maintenance. This should be carried out on an annual basis by a qualified technician and consist of the following:

10.2.1 HEAT PUMP

Check the following

- There are no refrigerant leaks. Refer to Section 10.6.
- Visual condition of the heat pump
- Any obstructions to airflow into the ASHP – remove if found
- The fan outlet grille is not obstructed - remove obstructions if found
- Condensate drain opening(s) are clear
- Pipe insulation condition
- Pressure relief valve hose discharge is clear
- Electrical power supply connections, hydraulic PCB and connections.

Inspect and clean the evaporator

- The air inlet grille and evaporator must be checked and any leaves or other debris removed from between the inlet grille and evaporator fins.

! CAUTION !

Take care not to damage or distort the Aluminium fins of the evaporator when removing any debris.

- Carefully remove any dirt or debris from the evaporator fins using either a soft brush or by gently vacuuming. Take care not to damage the fins during this manual cleaning process.
- Wash the evaporator with a neutral detergent cleaner, e.g. EnviroCoil, using a low-pressure spray.
- Do NOT use a pressure washer to clean the evaporator fins as this may damage them.
- Do NOT use any aggressive cleaning agents as these will attack and damage the aluminium fins.

Inspect and clean the air outlet grille

- The air outlet grille must be checked and any leaves or any other debris removed that could otherwise obstruct the operation of the fan(s) or the free flow of air from the heat pump.
- Ensure that both the air inlet to the evaporator and the discharge from the fan outlet are unobstructed. Any foliage, plants, etc. near the heat pump must not be allowed to grow over the heat pump.
- Under no circumstances should anything be stacked on or against the heat pump.
- Refer to Section 3.6.9 for the required clearances around the heat pump.

Inspect the condensate disposal

- Check that the condensate drain holes in the bottom of the heat pump are not blocked.
- Check that any condensate hoses are not blocked.
- Check that condensate is safely disposed of and not forming a pool beneath and around the heat pump.

Inspect electrical supply connections

- Remove right hand end side panel and the cover panel from the Hydraulic PCB enclosure.
- Visually inspect the electrical power supply connections checking for obvious defects such as loose connections or defective/damaged wiring. Also check Hydraulic PCB and connections.
- Replace cover panel on hydraulic PCB housing and right-hand end side panel when finished.

10.2.2 HEATING SYSTEM

Check the following:

- Expansion vessel pressure
- Operation of pressure relief valve
- Heating system pressure – top up if necessary
- Correct concentration of corrosion inhibitor/biocide protection
- Heating and hot water controls settings
- Any leaks on system
- Magnetic filter is cleaned

The following checks must be performed at least once a year by a qualified person:

Inspect system expansion vessel

- Check expansion vessel charge and re-pressurise as required.

Inspect system pressure relief valve

- Check for correct operation of the pressure relief valve.

Inspect pressure relief valve discharge pipe

- Check that the outlet of the pressure relief valve discharge pipe is positioned correctly, is unobstructed and water is seen to flow out when the pressure relief valve is tested, as above.

Check heating system water pressure

- If it is below 1 bar, top-up the water in the system.

Inspect the Magnetic filter

- Check and clean the water filter following the manufacturer's instructions.

10.3 CONDENSATE DISPOSAL

Check that the condensate drain holes in the bottom of the heat pump are not blocked.

10.4 HEATING SYSTEM CONNECTIONS

Check the condition of the flexible hoses. Replace if damaged or leaking. Check the presence and condition of the pipe insulation.

10.5 HEAT PUMP CONTROLS

Check that settings on the Grant Aerona Smart Controller are as set when commissioned.

Reset to commissioned settings if necessary.

For information relating to the commissioning requirements of the Grant Aerona Smart controller, refer to your supplied manual:

- DOC 0034 - smart heat pump system controller
- DOC 0033 - for systems with Grant Smart standard and pre-plumbed cylinder

10.6 REFRIGERANT

R290 is a propane gas with a purity of at least 99.5%. The gas is odourless so a leak would not be noticed by the sense of smell.

! WARNING !

R290 is classed as a hazardous substance and all technicians must ensure to have an appropriate level of safety awareness regardless of whether they handle the refrigerant or not.

Under no circumstances should the refrigerant be vented from the charging points on the refrigerant circuit of the heat pump.

If any work is required to be carried out on the refrigerant circuit, it **MUST** be undertaken by an F-gas registered refrigeration engineer.

On no account should any such work be carried out by unqualified personnel.

10.7 HEAT PUMP MONITORING

The heat pump operating conditions can be displayed via the touchscreen display of the Grant Aerona Smart Controller.

For information relating to the Heat pump accessibility on the Grant Aerona Smart controller, refer to your supplied manual:

- DOC 0034 - smart heat pump system controller
- DOC 0033 - for systems with Grant Smart standard and pre-plumbed cylinder

10.8 MAINTENANCE AND SERVICE

In order to ensure optimal availability of the unit, a number of checks and inspections on the unit and the field wiring have to be carried out at regular intervals.

This maintenance needs to be carried out by your local technician.

! WARNING !

ELECTRIC SHOCK

- **Before carrying out any maintenance or repair activities, switch off the power supply on the supply panel.**
- **DO not touch any live components or connections for at least 10 minutes after the power supply is turned off.**
- **Note that the crankcase heater of the compressor may operate even in standby mode.**
- **Some sections of the electric component box may be hot.**
- **Avoid touching any conductive parts.**

Do not rinse the unit with water as it may cause electric shock or fire.

Do not leave the unit unattended when the service panel is removed

10.9 HYDRAULIC PCB DIP SWITCHES

The hydraulic PCB has 4 dip switch blocks present which allow for the modification of some of the working parameters of the Grant Aerona R290. Some of these may need to be amended from new depending on the system that is being installed

If a hydraulic PCB is being replaced within a Grant Aerona R290 it will need to be checked prior to powering on the heat pump to ensure it is configured correctly.

In both cases refer to Tables 10-1 to 10-3 for dip switch configurations. Refer to Figure 10-1 for location of dip switches

Table 10-1: Dip switch Block 1 (SW1)

Switch	On	Off	Description
1	Hybrid	Non-Hybrid	Additional heat source (Boiler) is connected and managed via R290 heat pump.
2	No DHW	with DHW	DHW cylinder is connected and managed via R290 heat pump.
3 & 4*	OFF / OFF		Heat / Cool mode
	OFF / ON		Heat mode only
	ON / OFF		Cool mode only
	ON / ON		Disable Heat and Cool modes

*where multiple switches used ON/OFF displayed in ascending numerical order.

Table 10-2: Dip switch Block 2 (SW2)

Switch	On	Off	Description
1	Split	Monobloc	Setting for Split or Monobloc configuration (Aerona R290 is a Monobloc system)
2, 3 & 4*	OFF / OFF / OFF		4kW output mode
	OFF / ON / OFF		6.5kW output mode
	OFF / ON / ON		9kW output mode
	ON / OFF / OFF		12kW output mode
	ON / ON / OFF		16kW output mode

*where multiple switches used ON/OFF displayed in ascending numerical order.

Table 10-3: Dip switch Block 3 (SW3)

Switch	On	Off	Description
1 & 2*	OFF / OFF		Enable 3kW Internal Electric pipe heater.
	ON / ON		Disable 3kW Internal Electric pipe heater.
3 & 4*	OFF / OFF		Circulation pump 9m Head DC PWM Water pump (Factory fitted)

*where multiple switches used ON/OFF displayed in ascending numerical order.

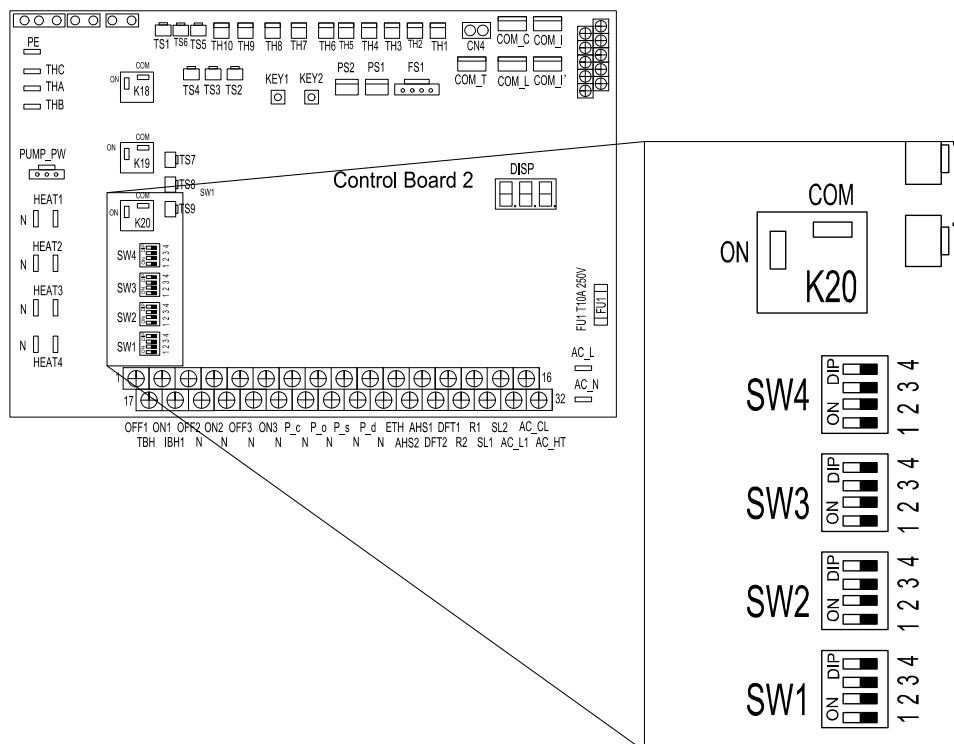

Figure 10-1: Hydraulic PCB Dip switches

11 FAULT FINDING

11.1 ERROR CODE DISPLAY

When there is a fault with the heat pump, an error code will be displayed on the touch screen display.

A list of all error codes and corrective actions can be found in Table 11-1.

Reset the fault when resolved by turning the unit OFF and back ON.

! NOTE !

Error codes displayed may be due to incorrect dip switch settings on the heat pump PCB.

Refer to Section 10-10 for dip switch settings and check these are correctly set for the heat pump model and installed system.

Fault number	Fault name	Failure analysis	Diagnosis method	Solution
P01	Water flow protection	<ol style="list-style-type: none"> Lack of water in water system Water flow switch is faulty Water system is blocked 	<ol style="list-style-type: none"> Check system water pressure Check whether the water flow switch is damaged/faulty Check if filter is blocked 	<ol style="list-style-type: none"> Fill system to correct pressure Change the water flow switch Clean or change the filter
P02	High pressure protection	<ol style="list-style-type: none"> Water flow is low High pressure switch is faulty Refrigerant system is blocked Electric expansion valve is locked (HP1, Occurring during operation) 	<ol style="list-style-type: none"> Check system water pressure and pump is operational Check high pressure switch connection/operation Check whether the refrigerant system is blocked Check whether there is electric expansion valve reset sound when the unit is in standby, and power is ON or OFF 	<ol style="list-style-type: none"> Fill system to correct pressure and check pump operation Change high pressure switch Change the filter of the refrigerant system Change the Electric expansion valve
P03	Low pressure protection	<ol style="list-style-type: none"> Lack of refrigerant Refrigerant system is blocked The heat pump is not running in regular operating conditions 	<ol style="list-style-type: none"> Check for leak in refrigerant circuit Check whether the filter in refrigerant circuit is blocked Check whether the outdoor ambient and inlet water temperature is normal 	<ol style="list-style-type: none"> Repair the leak Change the filter of refrigerant circuit If the ambient temperature and water temperature is too high or low, the unit will stop
P04	Condenser temperature overheat protection	<ol style="list-style-type: none"> Airflow of outdoor fan is insufficient Condenser is too dirty The temperature sensor (T3) is faulty 	<ol style="list-style-type: none"> Check whether there is any obstacle which is preventing the airflow Condenser is too dirty Check whether the condenser pipe temperature sensor (T3) seems in normal condition 	<ol style="list-style-type: none"> Clean the grille and evaporator Clean the condenser Replace the temperature sensor
P05	Discharge temperature protection	<ol style="list-style-type: none"> Lack of refrigerant Discharge temperature sensor is faulty 	<ol style="list-style-type: none"> Check for leak in refrigerant circuit Check whether the discharge temperature sensor (TP) seems in normal condition 	<ol style="list-style-type: none"> Repair the leak Replace the temperature sensor
P08	Middle pressure protection	<ol style="list-style-type: none"> Middle pressure switch not connected correctly The refrigerant PCB is faulty 	<ol style="list-style-type: none"> Check connections on sensor and refrigerant PCB Check refrigerant PCB 	<ol style="list-style-type: none"> Replace the middle pressure switch Replace refrigerant PCB
P11	DC fan 1 failure	<ol style="list-style-type: none"> The fan is faulty or stuck The refrigerant PCB is faulty (or drive PCB on 16 kW models) 	<ol style="list-style-type: none"> Check whether the fan is stuck or obstructed Check refrigerant PCB (or drive PCB on 16 kW models) 	<ol style="list-style-type: none"> Remove any obstructions or replace fan if faulty Replace the refrigerant PCB (or drive PCB on 16 kW models)
P12	DC fan 2 failure			
P13	4-way valve fault	<ol style="list-style-type: none"> Flow and return water temperature sensors are connected in reverse 4-way valve is faulty Hydraulic PCB is faulty 	<ol style="list-style-type: none"> Check whether the flow and return temperature sensors are connected in reverse Check whether action of 4-way valve is correct Check flow and return temperatures indicated the hydraulic PCB 	<ol style="list-style-type: none"> Connect sensors correctly, replace sensors if fault remains Switch repeatedly to check operation is correct. If not, replace If flow and return temperature are still incorrect, replace hydraulic PCB

Fault number	Fault name	Failure analysis	Diagnosis method	Solution
P14	Refrigerant leakage fault	<ol style="list-style-type: none"> 1. Leak in refrigerant circuit 2. Refrigerant leakage sensor failure 3. Hydraulic PCB is faulty 	<ol style="list-style-type: none"> 1. Check whether there is leakage in refrigerant circuit 2. Check whether refrigerant leakage sensor is normal 3. Check whether Hydraulic PCB is faulty 	<ol style="list-style-type: none"> 1. Repair leak in refrigerant circuit 2. Replace refrigerant leakage sensor 3. Replace Hydraulic PCB
P21	Abnormal operation of DC pump	<ol style="list-style-type: none"> 1. The water pump is faulty or stuck 2. The system lacks water or is blocked 3. Faulty connection between water pump and hydraulic PCB 4. The hydraulic PCB is faulty 	<ol style="list-style-type: none"> 1. Check operation of water pump 2. Check system water pressure, whether system is blocked (check filter) or valve(s) are closed 3. Check connections between water pump and hydraulic PCB 4. Check the hydraulic PCB 	<ol style="list-style-type: none"> 1. Replace water pump if faulty 2. Refill with water, remove blockage (clean filter) and open any closed valves 3. Correctly make connections on water pump and hydraulic PCB 4. Replace the hydraulic PCB if faulty
P25	Outlet pressure sensor failure	<ol style="list-style-type: none"> 1. Pressure sensor incorrectly connected 2. Sensor failure 3. The hydraulic PCB is faulty 	<ol style="list-style-type: none"> 1. Check correct connection of sensor 2. Use a multimeter to check if sensor has short circuit or is faulty 3. Check the hydraulic PCB 	<ol style="list-style-type: none"> 1. Connect sensor correctly 2. Replace sensor if faulty 3. Replace the hydraulic PCB if faulty
E02	Discharge temperature sensor failure (TP)	<ol style="list-style-type: none"> 1. Sensor incorrectly connected 2. Sensor failure 3. The hydraulic PCB is faulty 	<ol style="list-style-type: none"> 1. Check correct connection of sensor 2. Use a multimeter to check sensor 3. Check the hydraulic PCB 	<ol style="list-style-type: none"> 1. Connect sensor correctly 2. Replace sensor if faulty 3. Replace the hydraulic PCB if faulty
E03	Coil temperature sensor failure (T3)			
E04	Ambient temperature sensor failure (T4)			
E05	Liquid pipe temperature sensor failure (T5)			
E06	Return air temperature sensor failure (TH)			
E07	Water tank temperature sensor failure (TW)			
E08	Outlet water temperature sensor failure (TA)			
E09	Outlet water temperature sensor failure (TB)			
E10	Communication failure between hydraulic PCB and refrigerant PCB	<ol style="list-style-type: none"> 1. Communication cable incorrectly connected 2. The main hydraulic PCB is faulty 3. The refrigerant PCB is faulty 	<ol style="list-style-type: none"> 1. Check correct connection of communication cable 2. Check the hydraulic PCB 3. Check the refrigerant PCB 	<ol style="list-style-type: none"> 1. Replace or repair the communication cable 2. Replace the hydraulic PCB if faulty 3. Replace the refrigerant PCB if faulty
E13	Discharge pressure sensor fault	<ol style="list-style-type: none"> 1. Sensor connection incorrectly connected 2. Sensor failure 3. The refrigerant PCB is faulty 	<ol style="list-style-type: none"> 1. Check correct connection of sensor 2. Use a multimeter to check if sensor has short circuit or is faulty 3. Check the refrigerant PCB 	<ol style="list-style-type: none"> 1. Connect sensor correctly 2. Replace sensor if faulty 3. Replace the refrigerant PCB if faulty
E14	Low pressure sensor LPS failure			

Fault number	Fault name	Failure analysis	Diagnosis method	Solution
E15	DC bus voltage is too low			
E16	DC bus voltage is too high			
E17	AC current protection (input current)			
E18	IPM module is abnormal			
E19	PFC abnormal			
E20	Compressor failed to start			
E21	Compressor phase loss			
E22*	Inverter Module reset			
E23	Compressor over-current			
E24	PFC module temperature is too high	1. Cables incorrectly connected 2. Refrigerant & Drive PCB is faulty	1. Check all connections from the Refrigerant PCB (or Refrigerant & Drive PCB for the 16kW model) 2. Check the Refrigerant PCB (or Refrigerant & Drive PCB for the 16kW model)	1. Ensure all connections are made correctly. 2. Replace the Refrigerant PCB (and Drive PCB for the 16kW model) if faults remain
E25	Current detection circuit failure			
E26	Out of step			
E27	PFC module temperature sensor is abnormal			
E28	Communication fail			
E29	IPM module temperature is too high			
E30	IPM module temperature sensor failure			
E31	Reserved			
E32*	Reserved			
E33*	Reserved			

* These error codes indicate internal diagnostics active. Heat pump will not shut down.

Fault number	Fault name	Failure analysis	Diagnosis method	Solution
E34	AC input voltage is abnormal			
E35*	Drive EEPROM error			
E36	Power off reset			
E37*	Reserved	1. Cables incorrectly connected 2. Refrigerant & Drive PCB is faulty	1. Check all connections from the Refrigerant PCB (or Refrigerant & Drive PCB for the 16kW model) 2. Check the Refrigerant PCB (or Refrigerant & Drive PCB for the 16kW model)	1. Ensure all connections are made correctly. 2. Replace the Refrigerant PCB (and Drive PCB for the 16kW model) if faults remain
E38*	Reserved			
E57	GAS SENSOR OFFLINE			
E58	GAS SENSOR			

* These error codes indicate internal diagnostics active. Heat pump will not shut down.

12 SPARE PARTS

12.1 SPARE PARTS 4KW, 6.5KW, 9KW, 12KW, 16KW

PRODUCT CODES	REF. NO.	DESCRIPTION	4KW	6.5KW	9KW	12KW	16KW
Fan Blade(s)							
AX002	2	FAN 4kW	YES				
AX003	2	FAN 6.5kW AND 9kW		YES	YES		
AX001	2	FAN 12kW AND 16kW				YES	YES
Grills							
AX006	1.2	GRILL 4kW	YES				
AX008	1.2	GRILL 6.5kW AND 9kW		YES	YES		
AX007	1.2	GRILL 12kW AND 16kW				YES	YES
Panels							
AX010	22	TOP COVER 12kW AND 16kW				YES	YES
AX011	31	FRONT PANEL - WIND DEFLECTOR 6.5kW AND 9kW		YES	YES		
AX012	1	FRONT PANEL ASSEMBLY 12kW AND 16kW				YES	YES
AX013	33	FRONT LEFT PANEL 12kW AND 16kW				YES	YES
AX014	12.1	LEFT ACOUSTIC PANEL 6.5kW		YES			
AX015	31	LEFT PANEL ASSEMBLY 4kW	YES				
AX016	1.1	FRONT LEFT PANEL ASSEMBLY 4kW	YES				
AX017	25	TOP COVER 4kW	YES				
AX018	26	CONDENSER COVER PLATE 4kW	YES				
AX019	30	REAR-RIGHT SIDE PLATE ASSEMBLY 4kW	YES				
AX020	28	RIGHT PANEL 4kW	YES				
AX021	29	RIGHT FRONT COLUMN 4kW	YES				
AX022	21	CONDENSER COVER PLATE 12kW				YES	
AX023	11	BASE ASSEMBLY 12kW AND 16kW				YES	YES
AX024	13	BASE ASSEMBLY 6.5kW AND 9kW		YES	YES		
AX025	1.1	FRONT PANEL ASSEMBLY 6.5kW AND 9kW		YES	YES		
AX026	32	LEFT PANEL 6.5kW AND 9kW		YES	YES		
AX027	25	TOP COVER 6.5kW AND 9kW		YES	YES		
AX028	26	CONDENSER COVER PLATE 6.5kW AND 9kW		YES	YES		
AX029	30	REAR-RIGHT SIDE PLATE ASSEMBLY 6.5kW AND 9kW		YES	YES		
AX030	28	RIGHT PANEL 6.5kW AND 9kW		YES	YES		
AX031	29	RIGHT FRONT COLUMN 6.5kW AND 9kW		YES	YES		
AX032	5	COVER OF ELECTRIC BOX 4kW	YES				
AX033	9	FIXED PLATE FOR HEAT EXCHANGE 4kWR	YES				
AX034	5	COVER OF ELECTRIC BOX 6.5kW AND 9kW		YES	YES		
AX035	9	FIXED PLATE FOR HEAT EXCHANGER 6.5kW AND 9kW		YES	YES		
AX036	4	MOTOR BRACKET 12kW AND 16kW				YES	YES
AX037	4	MOTOR BRACKET 6.5kW AND 9kW		YES	YES		
AX038	4	MOTOR BRACKET 4kW	YES				
AX039	7	COVER OF REACTOR 16kW					YES
AX040	30	CONNECTING PLATE 12kW AND 16kW				YES	YES
AX041	9	FIXED PLATE FOR HEAT EXCHANGER 12kW AND 16kW				YES	YES
AX042	12	RIGHT FRONT COLUMN 12kW AND 16kW				YES	YES
AX043	31	RIGHT PANEL 12kW AND 16kW				YES	YES
AX044	32	REAR-RIGHT SIDE PLATE ASSEMBLY 12kW AND 16kW				YES	YES
AX045	34	LEFT PANEL 12kW AND 16kW				YES	YES
AX046	7	COVER OF REACTOR 9kW AND 12kW			YES	YES	
AX047	21	CONDENSER COVER PLATE 16kW					YES
AX048	7	COVER OF REACTOR 6.5kW		YES			

PRODUCT CODES	REF. NO.	DESCRIPTION	4KW	6.5KW	9KW	12KW	16KW
AX049	11	PARTITION BOARD ASSEMBLY 4kW	YES				
AX050	11	PARTITION BOARD ASSEMBLY 6.5kW AND 9kW		YES	YES		
AX051	27	CONDENSER CONNECTING PLATE 4kW	YES				
AX052	27	CONDENSER CONNECTING PLATE 6.5kW AND 9kW		YES	YES		
AX053	5	COVER OF ELECTRIC BOX 12kW				YES	
AX054	6	ELECTRIC CONTROL BOX COMPONENTS 16kW					YES
AX055	5	COVER OF ELECTRIC BOX 16kW					YES
AX056	6	ELECTRIC CONTROL BOX COMPONENTS 12kW				YES	
AX057	13		YES				
Compressors							
AX058	28	COMPRESSOR 16kW					YES
AX059	28	COMPRESSOR 12kW				YES	
AX060	12	COMPRESSOR 9kW			YES		
AX061	12	COMPRESSOR 4kW	YES				
AX062	12	COMPRESSOR 6.5kW		YES			
Evaporators							
AX065	24	EVAPORATOR 4kW	YES				
AX063	24	EVAPORATOR 6.5kW		YES			
AX064	24	EVAPORATOR 9kW			YES		
AX066	29	EVAPORATOR 12kW				YES	
AX067	29	EVAPORATOR 16kW					YES
Electric Expansion Valve							
AX068		ELECTRIC EXPANSION VALVE ALL MODELS				YES	YES
AX143	18	ELECTRIC EXPANSION VALVE 4kW	YES				
AX142	18	ELECTRIC EXPANSION VALVE 6.5kW AND 9kW		YES	YES		
AX075	17	ELECTRIC EXPANSION VALVE 12kW				YES	
AX074	17	ELECTRIC EXPANSION VALVE 16kW					YES
Liquid Storage Tanks							
AX076	21	LIQUID STORAGE TANK ASSEMBLY 4kW, 6.5kW AND 9kW	YES	YES	YES		
AX077	23	LIQUID STORAGE TANK ASSEMBLY 12kW AND 16kW				YES	YES
4-way Valves							
AX080	20.2	4-WAY VALVE COIL 4kW, 6.5kW, 9kW, AND 12kW	YES	YES	YES	YES	
AX069	24.1	4-WAY VALVE COIL 16kW					YES
AX071	20.1	4-WAY VALVE BODY 4kW	YES				
AX072	20.1	4-WAY VALVE BODY 6.5kW AND 9kW		YES	YES		
AX085	20	4-WAY VALVE ASS'Y 4kW	YES				
AX084	20	4-WAY VALVE ASS'Y 6.5kW		YES			
AX083	20	4-WAY VALVE ASS'Y 9kW			YES		
AX073	24	4-WAY VALVE ASS'Y 12kW				YES	
AX070	24	4-WAY VALVE ASS'Y 16kW					YES
Plate Heat exchanger							
AX086	10	PLATE HEAT EXCHANGER 6.5kW		YES			
AX087	10	PLATE HEAT EXCHANGER 4kW	YES				
AX088	10	PLATE HEAT EXCHANGER 9kW			YES		
AX089	10	PLATE HEAT EXCHANGER 12kW AND 16kW				YES	YES
Reactors							
AX091	8	REACTOR 9kW AND 12kW			YES	YES	
AX092	8	REACTOR 6.5kW		YES			
AX093	8	REACTOR 16kW					YES

PRODUCT CODES	REF. NO.	DESCRIPTION	4KW	6.5KW	9KW	12KW	16KW
Inverter PCB boards							
AX094	6.1	POWER PCB ASS'Y 4kW	YES				
AX097	6.1	POWER PCB ASS'Y 6.5kW		YES			
AX095	6.1	POWER PCB ASS'Y 9kW			YES		
AX096	6.1	POWER PCB ASS'Y 12kW				YES	
AX118	6.1	POWER PCB ASS'Y 16kW					YES
AX120		POWER PCB ASS'Y 16kW					YES
Control PCB's							
AX121	6.2	MAIN PCB ASS'Y 4kW, 6.5kW AND 9kW	YES	YES	YES		
AX119	6.2	MAIN PCB ASS'Y 12kW AND 16kW				YES	YES
Sensors							
AX098	42	COIL TEMPERATURE SENSOR 12kW				YES	
AX099	41	OUTDOOR ROOM TEMPERATURE SENSOR 12kW				YES	
AX100	43	LIQUID TUBE TEMPERATURE SENSOR 12kW				YES	
AX101	45	INLET TEMPERATURE SENSOR 12kW AND 16kW				YES	YES
AX102	46	OUTLET TEMPERATURE SENSOR 12kW AND 16kW				YES	YES
AX103	27	SUCTION TEMPERATURE SENSOR 12kW				YES	
AX104	26	DISCHARGE PIPE TEMPERATURE SENSOR 12kW AND 16kW				YES	YES
AX105	40.2	DISCHARGE PIPE TEMPERATURE SENSOR 4kW, 6.5kW AND 9kW	YES	YES	YES		
AX106	40.4	SUCTION/INLET TEMPERATURE SENSOR 4kW, 6.5kW AND 9kW	YES	YES	YES		
AX107	40.3	COIL TEMPERATURE SENSOR 4kW, 6.5kW AND 9kW	YES	YES	YES		
AX108	40.1	OUTDOOR ROOM TEMPERATURE SENSOR 4kW, 6.5kW AND 9kW	YES	YES	YES		YES
AX109	40.5	LIQUID TUBE/ OUTLET TEMPERATURE SENSOR 4kW, 6.5kW AND 9kW	YES	YES	YES		
AX110	40.6	WATER TEMPERATURE SENSOR ALL MODELS	YES	YES	YES	YES	YES
AX111	39	REFRIGERANT SENSOR ALL MODELS	YES	YES	YES	YES	YES
AX112	26	DISCHARGE PIPE TEMPERATURE SENSOR 16kW					YES
AX113	27	SUCTION TEMPERATURE SENSOR 16kW					YES
AX114	16	WATER PRESSURE SENSOR ALL MODELS	YES	YES	YES	YES	YES
AX115	19	WATER FLOW SWITCH ALL MODELS	YES	YES	YES	YES	YES
Water Pressure switch							
AX116	20.5	PRESSURE SWITCH 4kW, 6.5kW, 9kW AND 16kW	YES	YES	YES		YES
AX117	25	PRESSURE SWITCH 12kW				YES	
Fan Motor							
AX122	3	MOTOR ASS'Y 12kW AND 16kW				YES	YES
AX123	3	MOTOR ASS'Y 4kW	YES				
AX124	3	MOTOR ASS'Y 6.5kW AND 9kW		YES	YES		
Pump							
AX125	15	SHIELDED PUMP ALL MODELS	YES	YES	YES	YES	YES
Wire Holder							
AX126	6.5	WIRE HOLDER-2 POSITION ALL MODELS	YES	YES	YES	YES	YES
AX127	6.3	WIRE HOLDER-3 POSITION ALL MODELS	YES	YES	YES	YES	YES
AX128	6.4	WIRE HOLDER-6 POSITION 4kW, 6.5kW AND 9kW	YES	YES	YES		
Crankcase heater							
AX132	12.2	COMPRESSOR ELECTRIC HEATER 4kW AND 6.5kW	YES	YES			
AX130	12.2	COMPRESSOR ELECTRIC HEATER 9kW			YES		
AX129	47	COMPRESSOR ELECTRIC HEATER 16kW					YES
Defrost heater							
AX133	41	CHASSIS HEATING BELT 4kW, 6.5kW AND 9kW	YES	YES	YES		
AX131	48	CHASSIS HEATING BELT 12kW AND 16kW				YES	YES

PRODUCT CODES	REF. NO.	DESCRIPTION	4KW	6.5KW	9KW	12KW	16KW
Drain Hose							
AX137	35	DRAIN HOSE 4kW, 6.5kW AND 9kW	YES	YES	YES		
AX004	36	DRAIN HOSE 12kW AND 16kW				YES	YES
Sensor clamp							
AX005	39	SENSOR CLAMP 12kW AND 16kW				YES	YES
AX009	38	SENSOR CLAMP 4kW, 6.5kW AND 9kW	YES	YES	YES		
Inline water heater							
AX147	22	Electrical heating	YES				
AX138	6	ELECTRIC CONTROL BOX COMPONENTS 6.5kW AND 9kW		YES	YES		
AX139	12.1	COMPRESSOR COAMING PLATE ASSEMBLY 9kW			YES		
AX140	12.1	COMPRESSOR COAMING PLATE ASSEMBLY 4kW	YES				
AX141	6	EXTERNAL PANEL ELECTRIC CONTROL BOX ASSEMBLY 4kW	YES				
AX078	20.4	PIN VALVE ALL MODELS	YES	YES	YES	YES	YES
AX079	33	METER CONNECTOR ALL MODELS	YES	YES	YES	YES	YES
AX081	23	EXHAUST VALVE ALL MODELS	YES	YES	YES	YES	YES
AX082	17	RELIEF VALVE ALL MODELS	YES	YES	YES	YES	YES
AX090	19	INSULATION PIPE 12kW AND 16kW				YES	YES
AX144	20.3	PRESSURE SENSOR 4kW, 6.5kW AND 9kW	YES	YES	YES		
AX145	6.4	CRIMPING CLAMP 12kW AND 16kW				YES	YES

12.1.1 EXPLODED DIAGRAM - HPR290I40 - 4KW

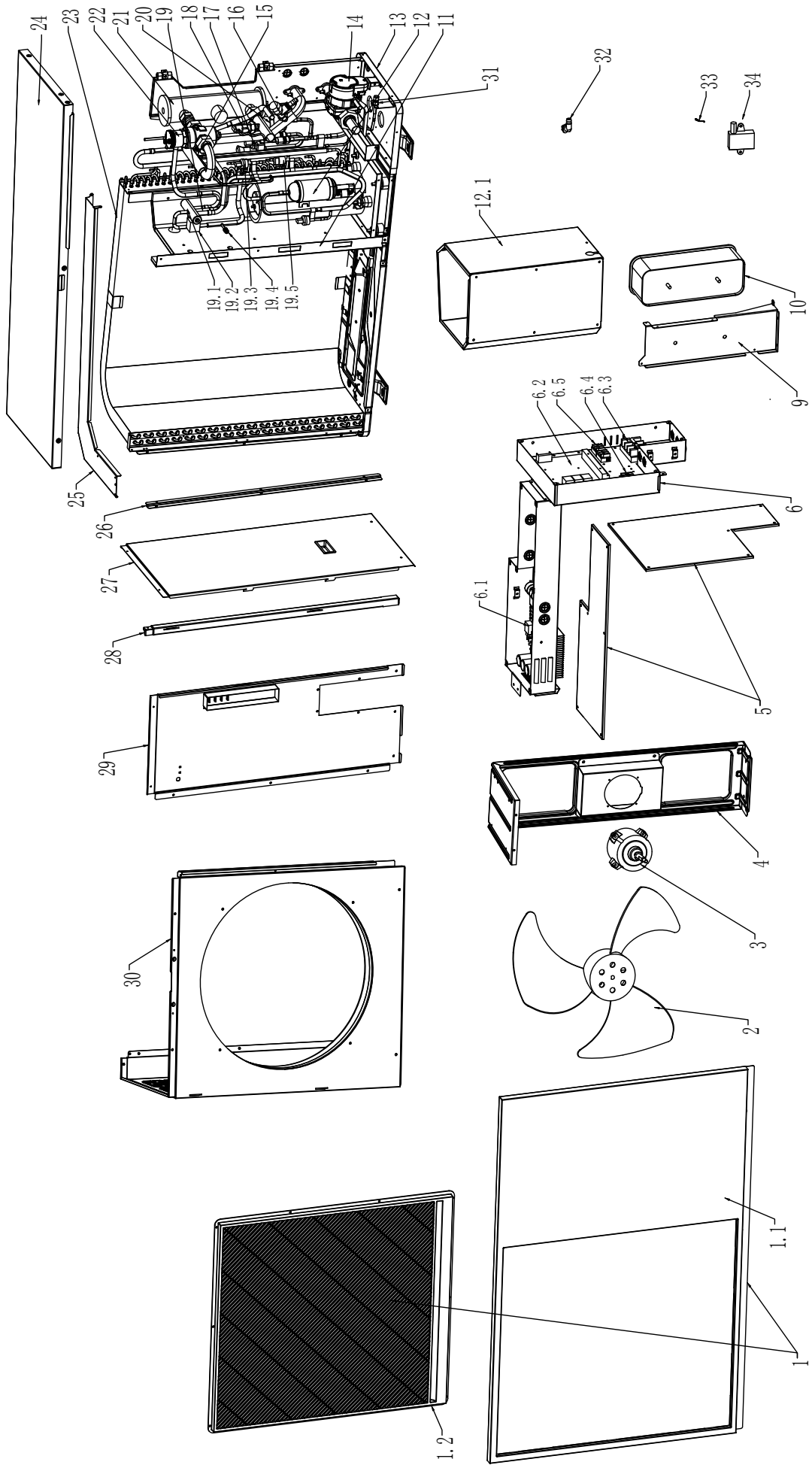

12.1.2 EXPLODED DIAGRAM - HPR290165- 6.5KW

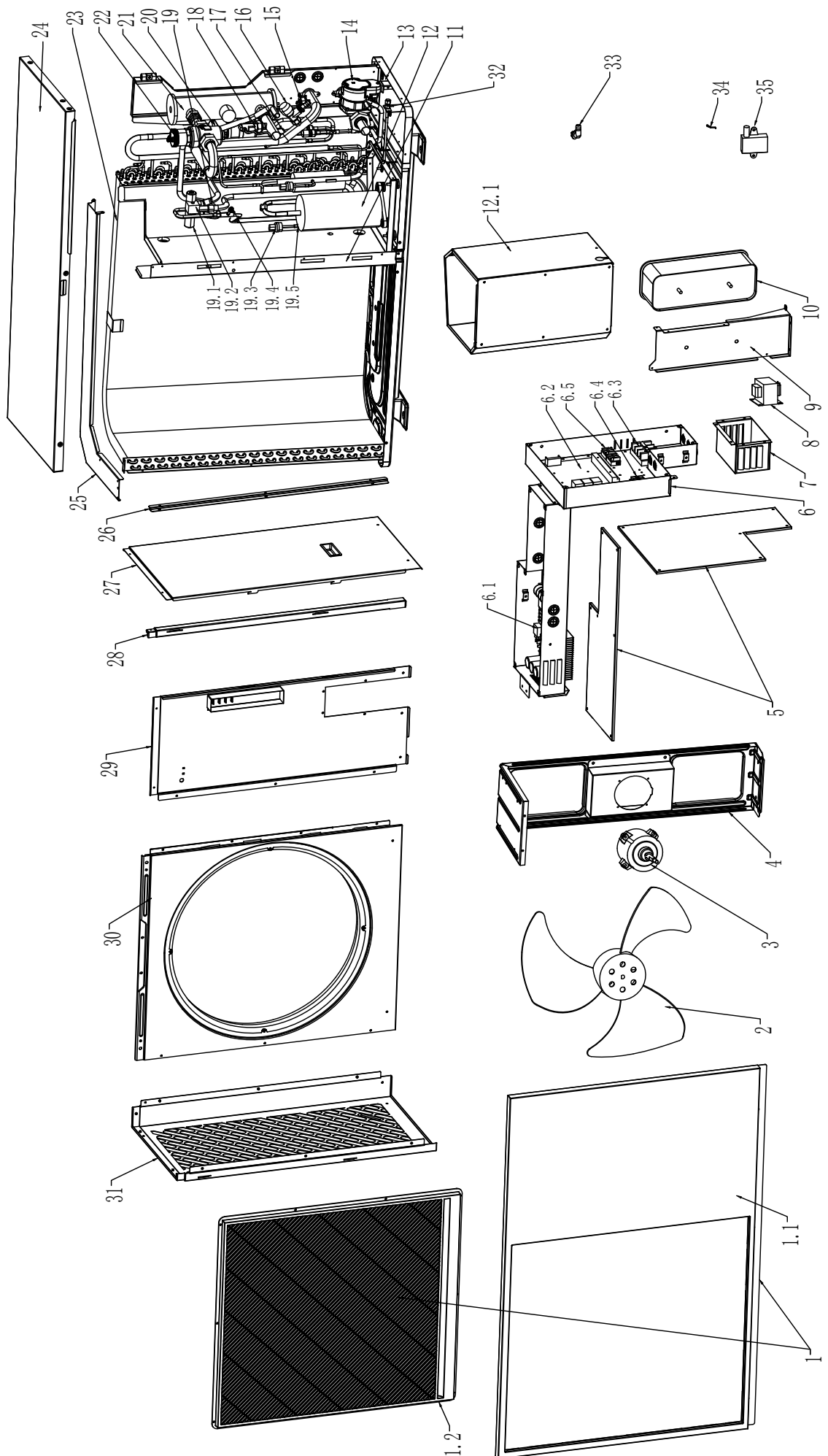

12.1.3 EXPLODED DIAGRAM - HPR290I90- 9KW

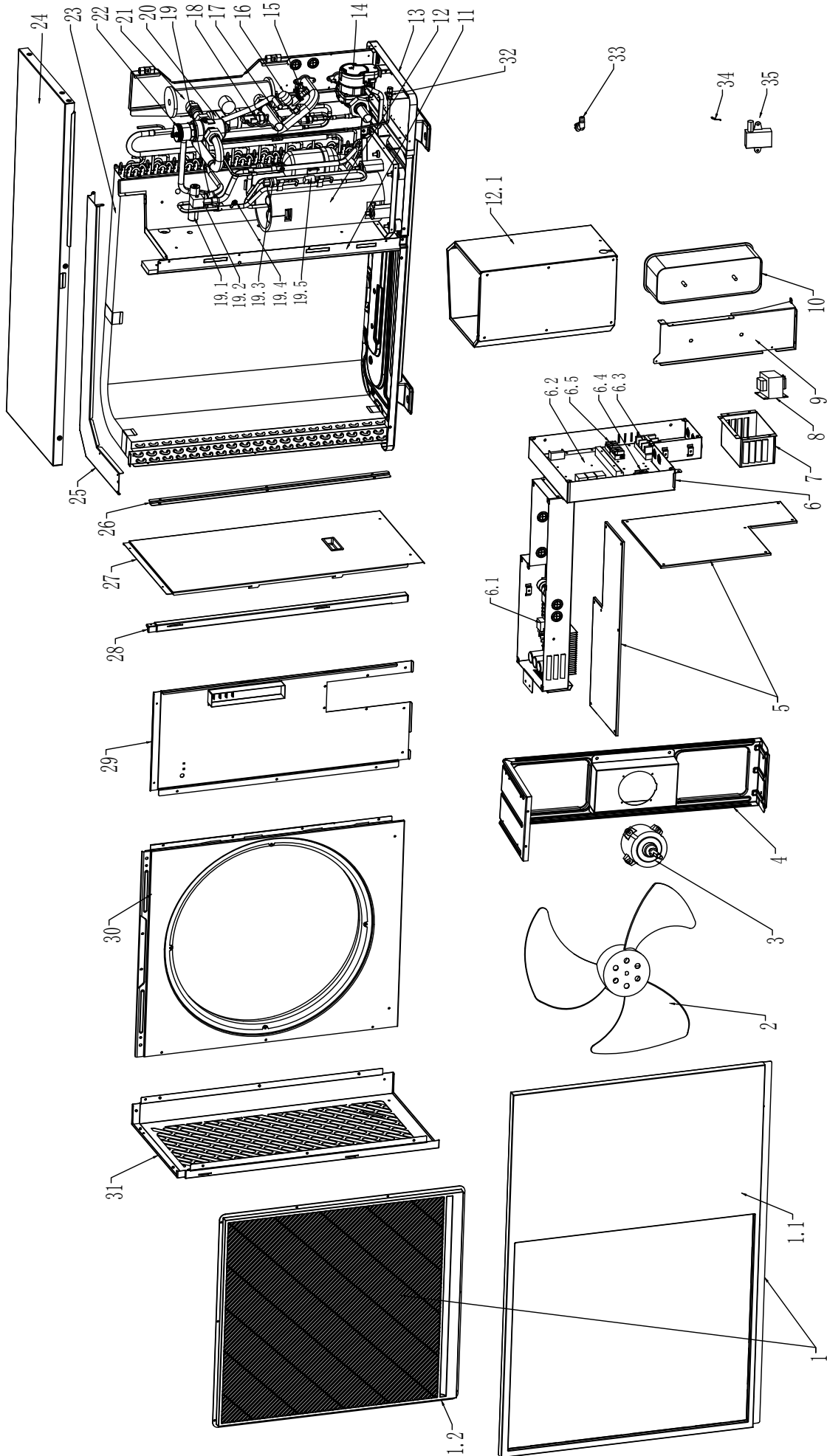

12.1.4 EXPLODED DIAGRAM - HPR290I120 - 12KW

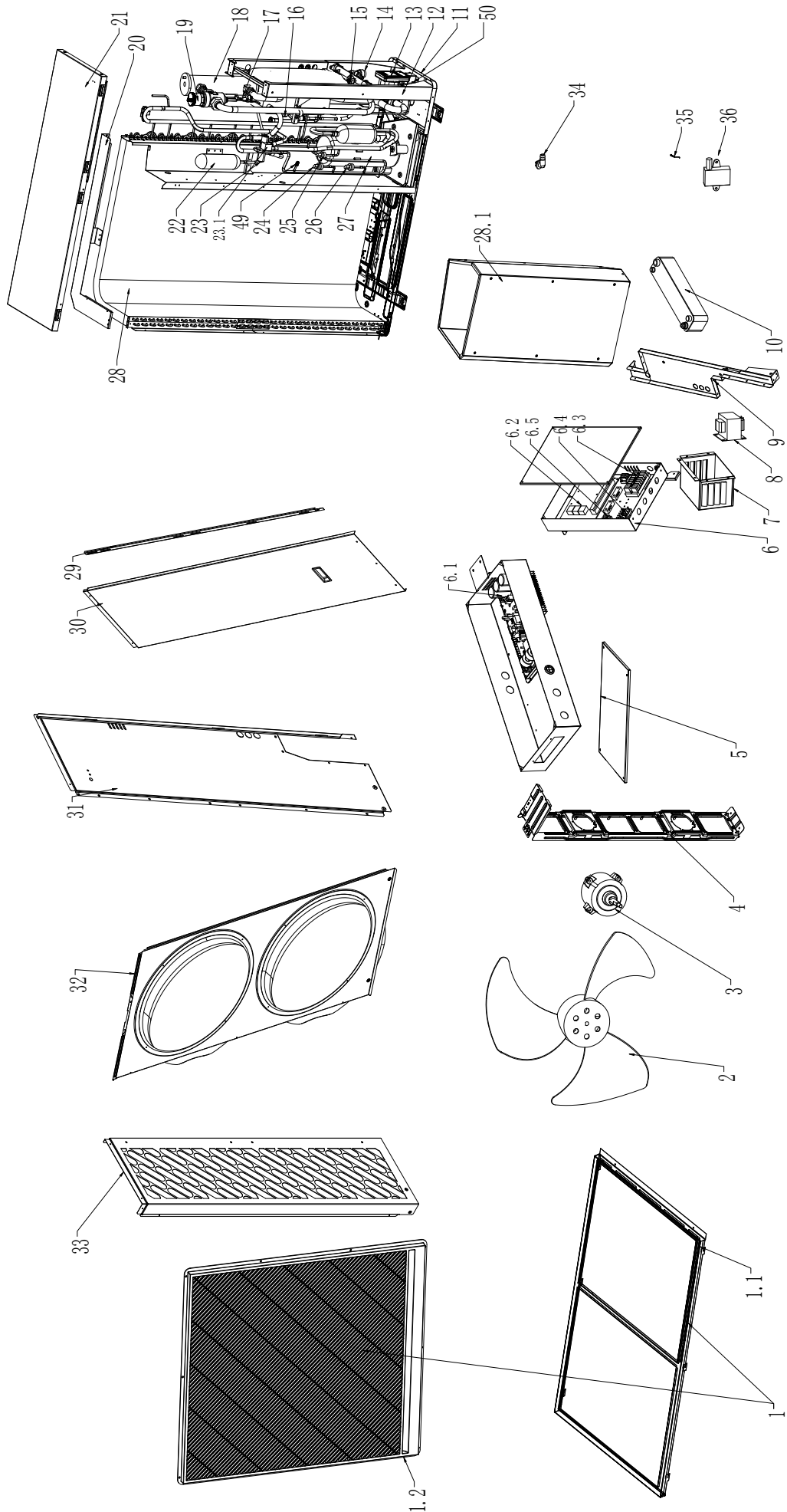

12.1.5 EXPLODED DIAGRAM - HPR2901160 - 16KW

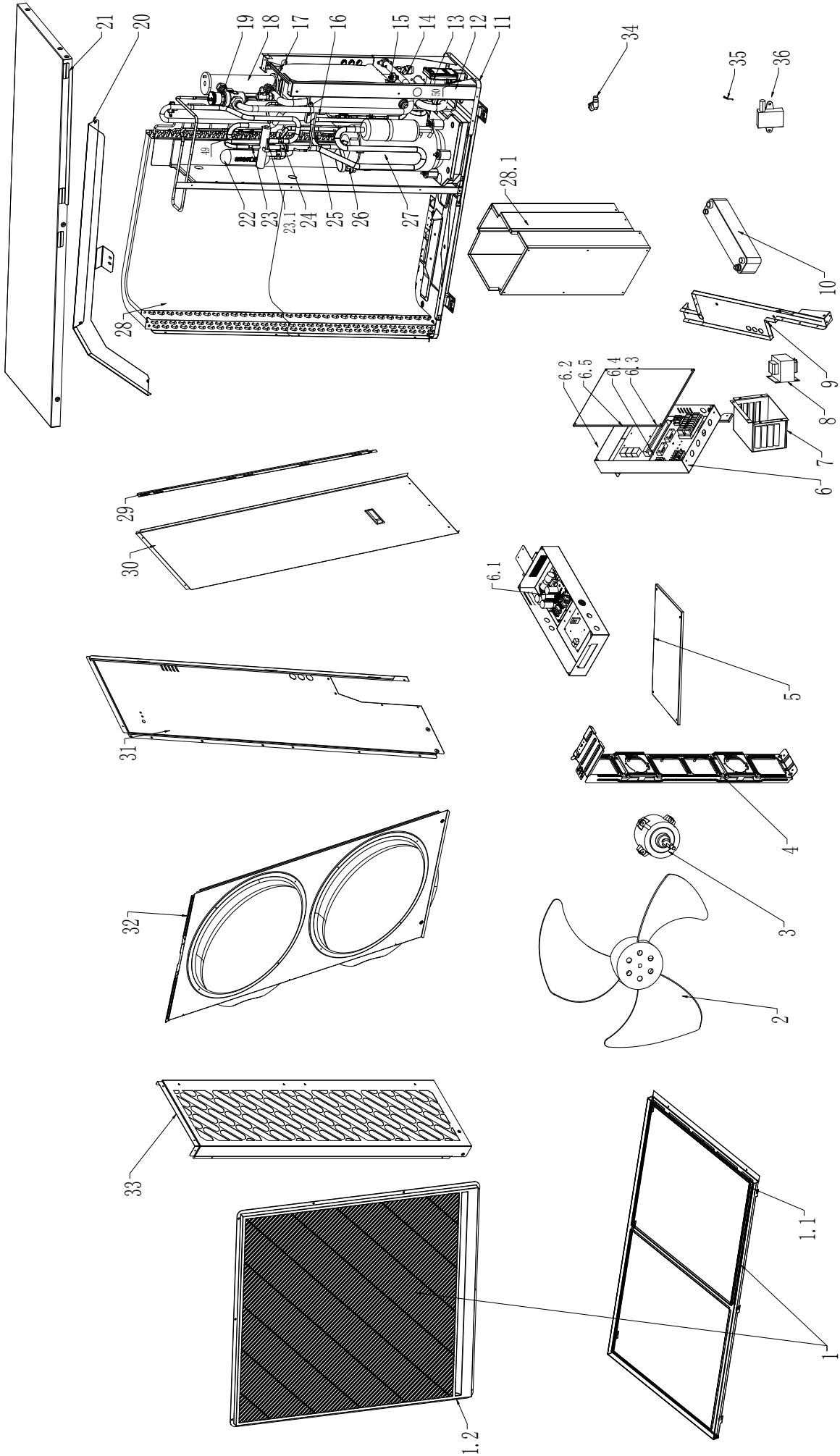

13 DECLARATION OF CONFORMITY

13.1 SAFETY DECLARATION OF CONFORMITY

Declaration of Conformity

This declaration of conformity is issued under the sole responsibility of the manufacturer/

Product Air to Water Monobloc Heat Pump
Code HPR290i40, HPR290i65, HPR290i90, HPR290i120 & HPR290i160,

Electromagnetic Compatibility Directive 2014/30/EU

EN IEC 55014-1:2021 EN IEC 55014-2:2021
EN 61000-3-2:2019 +A1:2021¹ EN 61000-3-3:2013+A1:2019+A2:2021¹
EN 61000-3-11:2019² EN 61000-3-12:2011+A1:2024²

¹ Models HPR290i40, HPR290i65

² Models HPR290i90, HPR290i120 & HPR290i160

Low voltage Directive 2014/35/EU

EN 62233:2008:2008 EN 60335-2-40:2003+A11:2004+A12:2005+A1:2006+A2:2009+A13:2012
EN 60335-1:2012+A16:2023

Ecodesign for Energy Related products.

EN 14511:2022 EN 14825:2022 EN16147:2017

Pressure Equipment (safety) Regulations 2016

EN 378-2:2016

I hereby declare that the equipment named above has been tested and found to comply with the relevant sections of the above referenced specifications. The unit complies with all essential requirements of the Directives.

Responsible Person: Mr. Peter Darcy

Position: R&D Manager



Date: 2nd December 2024

14 PRODUCT FICHE

14.1 HPR290I40 FICHE

Product Fiche Concerning the COMMISSION DELEGATED REGULATIONS

(EU)No 811/2013 of 18 February 2013

(EU)No 813/2013 of 2 August 2013

Supplier name or trademark	Grant Engineering (Ireland) ULC
Model identifier	Aerona HPR290I40
Seasonal space heating energy efficiency class (average climate conditions - Low-temperature)	A+++
Seasonal space heating energy efficiency class (average climate conditions - medium temperature)	A++
Rated heat output (average climate conditions – Low temperature)	4 kW
Rated heat output (average climate conditions – Medium temperature)	4 kW
Seasonal space heating energy efficiency (average climate conditions - Low-temperature)	200 %
Seasonal space heating energy efficiency (average climate conditions - Medium temperature)	146 %
Annual energy consumption - final energy (average climate conditions - Low-temperature)	1 664 kWh
Annual energy consumption - GCV (average climate conditions - Low-temperature)	- GJ
Annual energy consumption - final energy (average climate conditions - Medium temperature)	2 411 kWh
Annual energy consumption - GCV (average climate conditions - Medium temperature)	- GJ
Sound power level (Indoors)	- dB
Specific precautions	All specific precautions for assembly, installation and maintenance are described in the operating and installation instructions. Read and follow the operating and installation instructions.
Additional information	
Rated heat output (colder climate conditions - Low-temperature)	- kW
Rated heat output (warmer climate conditions - Low temperature)	- kW
Rated heat output (colder climate conditions – Medium temperature)	- kW
Rated heat output (warmer climate conditions – Medium temperature)	- kW
Seasonal space heating energy efficiency (colder climate conditions - Low-temperature)	- %
Seasonal space heating energy efficiency (warmer climate conditions - Low-temperature)	- %
Seasonal space heating energy efficiency (colder climate conditions - Medium temperature)	- %
Seasonal space heating energy efficiency (warmer climate conditions - Medium temperature)	- %
Annual energy consumption - final energy (colder climate conditions - Low-temperature)	- kWh
Annual energy consumption - GCV (colder climate conditions - Low-temperature)	- GJ
Annual energy consumption - final energy (warmer climate conditions - Low-temperature)	- kWh
Annual energy consumption- GCV (warmer climate conditions - Low-temperature)	- GJ
Annual energy consumption - final energy (colder climate conditions - Medium temperature)	- kWh
Annual energy consumption - GCV (colder climate conditions - Medium temperature)	- GJ
Annual energy consumption - final energy (warmer climate conditions - Medium temperature)	- kWh
Annual energy consumption- GCV (warmer climate conditions - Medium temperature)	- GJ
Sound power level (Outdoors)	- 48 dB

Model placed on the Union market from 01/12/2024



EPREL registration number: 2199863

EPREL: <https://eprel.ec.europa.eu/screen/product/spaceheaters/2199863>

Supplier: Grant Engineering (Ireland)

Customer care service:

Website: www.grant.eu

Name: Grant R&D Department

Phone: +353 (0)57 91 20089

Email: info@grant.eu

Address:

Barrack Street, Crinkle, Birr,
Co. Offaly, R42 D788, Ireland

14.2 HPR290165 FICHE

Product Fiche Concerning the COMMISSION DELEGATED REGULATIONS

(EU)No 811/2013 of 18 February 2013

(EU)No 813/2013 of 2 August 2013

Supplier name or trademark	Grant Engineering (Ireland) ULC
Model identifier	Aerona HPR290i65
Seasonal space heating energy efficiency class (average climate conditions - Low-temperature)	A+++
Seasonal space heating energy efficiency class (average climate conditions - medium temperature)	A++
Rated heat output (average climate conditions - Low temperature)	7 kW
Rated heat output (average climate conditions - Medium temperature)	7 kW
Seasonal space heating energy efficiency (average climate conditions - Low-temperature)	203 %
Seasonal space heating energy efficiency (average climate conditions - Medium temperature)	145 %
Annual energy consumption - final energy (average climate conditions - Low-temperature)	2 603 kWh
Annual energy consumption - GCV (average climate conditions - Low-temperature)	- GJ
Annual energy consumption - final energy (average climate conditions - Medium temperature)	3 633 kWh
Annual energy consumption - GCV (average climate conditions - Medium temperature)	- GJ
Sound power level (Indoors)	- dB
Specific precautions	All specific precautions for assembly, installation and maintenance are described in the operating and installation instructions. Read and follow the operating and installation instructions.
Additional information	
Rated heat output (colder climate conditions - Low-temperature)	- kW
Rated heat output (warmer climate conditions - Low temperature)	- kW
Rated heat output (colder climate conditions - Medium temperature)	- kW
Rated heat output (warmer climate conditions - Medium temperature)	- kW
Seasonal space heating energy efficiency (colder climate conditions - Low-temperature)	- %
Seasonal space heating energy efficiency (warmer climate conditions - Low-temperature)	- %
Seasonal space heating energy efficiency (colder climate conditions - Medium temperature)	- %
Seasonal space heating energy efficiency (warmer climate conditions - Medium temperature)	- %
Annual energy consumption - final energy (colder climate conditions - Low-temperature)	- kWh
Annual energy consumption - GCV (colder climate conditions - Low-temperature)	- GJ
Annual energy consumption - final energy (warmer climate conditions - Low-temperature)	- kWh
Annual energy consumption- GCV (warmer climate conditions - Low-temperature)	- GJ
Annual energy consumption - final energy (colder climate conditions - Medium temperature)	- kWh
Annual energy consumption - GCV (colder climate conditions - Medium temperature)	- GJ
Annual energy consumption - final energy (warmer climate conditions - Medium temperature)	- kWh
Annual energy consumption- GCV (warmer climate conditions - Medium temperature)	- GJ
Sound power level (Outdoors)	- 52 dB

Model placed on the Union market from 01/12/2024



EPREL registration number: 2222156

EPREL: <https://eprel.ec.europa.eu/screen/product/spaceheaters/2222156>

Supplier: Grant Engineering (Ireland)

Customer care service:

Website: www.grant.eu

Name: Grant R&D Department

Phone: +353 (0)57 91 20089

Email: info@grant.eu

Address:
Barrack Street, Crinkle, Birr,
Co. Offaly, R42 D788, Ireland

14.3 HPR290I90 FICHE

Product Fiche Concerning the COMMISSION DELEGATED REGULATIONS

(EU)No 811/2013 of 18 February 2013

(EU)No 813/2013 of 2 August 2013

Supplier name or trademark	Grant Engineering (Ireland) ULC
Model identifier	Aerona HPR290i90
Seasonal space heating energy efficiency class (average climate conditions - Low-temperature)	A+++
Seasonal space heating energy efficiency class (average climate conditions - medium temperature)	A++
Rated heat output (average climate conditions – Low temperature)	9 kW
Rated heat output (average climate conditions – Medium temperature)	9 kW
Seasonal space heating energy efficiency (average climate conditions - Low-temperature)	189 %
Seasonal space heating energy efficiency (average climate conditions - Medium temperature)	148 %
Annual energy consumption - final energy (average climate conditions - Low-temperature)	3 864 kWh
Annual energy consumption - GCV (average climate conditions - Low-temperature)	- GJ
Annual energy consumption - final energy (average climate conditions - Medium temperature)	4 659 kWh
Annual energy consumption - GCV (average climate conditions - Medium temperature)	- GJ
Sound power level (Indoors)	- dB
Specific precautions	All specific precautions for assembly, installation and maintenance are described in the operating and installation instructions. Read and follow the operating and installation instructions.
Additional information	
Rated heat output (colder climate conditions - Low-temperature)	- kW
Rated heat output (warmer climate conditions - Low temperature)	- kW
Rated heat output (colder climate conditions – Medium temperature)	- kW
Rated heat output (warmer climate conditions – Medium temperature)	- kW
Seasonal space heating energy efficiency (colder climate conditions - Low-temperature)	- %
Seasonal space heating energy efficiency (warmer climate conditions - Low-temperature)	- %
Seasonal space heating energy efficiency (colder climate conditions - Medium temperature)	- %
Seasonal space heating energy efficiency (warmer climate conditions - Medium temperature)	- %
Annual energy consumption - final energy (colder climate conditions - Low-temperature)	- kWh
Annual energy consumption - GCV (colder climate conditions - Low-temperature)	- GJ
Annual energy consumption - final energy (warmer climate conditions - Low-temperature)	- kWh
Annual energy consumption- GCV (warmer climate conditions - Low-temperature)	- GJ
Annual energy consumption - final energy (colder climate conditions - Medium temperature)	- kWh
Annual energy consumption - GCV (colder climate conditions - Medium temperature)	- GJ
Annual energy consumption - final energy (warmer climate conditions - Medium temperature)	- kWh
Annual energy consumption- GCV (warmer climate conditions - Medium temperature)	- GJ
Sound power level (Outdoors)	- 54 dB

Model placed on the Union market from 01/12/2024



EPREL registration number: 2222203

Supplier: Grant Engineering (Ireland)

Customer care service:

Name: Grant R&D Department

Email: info@grant.eu

Address:
Barrack Street, Crinkle, Birr,
Co. Offaly, R42 D788, Ireland

EPREL: <https://eprel.ec.europa.eu/screen/product/spaceheaters/2222203>

Website: www.grant.eu

Phone: +353 (0)57 91 20089

14.4 HPR2901120 FICHE

Product Fiche Concerning the COMMISSION DELEGATED REGULATIONS

(EU)No 811/2013 of 18 February 2013

(EU)No 813/2013 of 2 August 2013

Supplier name or trademark	Grant Engineering (Ireland) ULC
Model identifier	Aerona HPR290i120
Seasonal space heating energy efficiency class (average climate conditions - Low-temperature)	A+++
Seasonal space heating energy efficiency class (average climate conditions - medium temperature)	A++
Rated heat output (average climate conditions – Low temperature)	11 kW
Rated heat output (average climate conditions – Medium temperature)	11 kW
Seasonal space heating energy efficiency (average climate conditions - Low-temperature)	190 %
Seasonal space heating energy efficiency (average climate conditions - Medium temperature)	150 %
Annual energy consumption - final energy (average climate conditions - Low-temperature)	4 803 kWh
Annual energy consumption - GCV (average climate conditions - Low-temperature)	- GJ
Annual energy consumption - final energy (average climate conditions - Medium temperature)	6 069 kWh
Annual energy consumption - GCV (average climate conditions - Medium temperature)	- GJ
Sound power level (Indoors)	- dB
Specific precautions	All specific precautions for assembly, installation and maintenance are described in the operating and installation instructions. Read and follow the operating and installation instructions.
Additional information	
Rated heat output (colder climate conditions - Low-temperature)	- kW
Rated heat output (warmer climate conditions - Low temperature)	- kW
Rated heat output (colder climate conditions – Medium temperature)	- kW
Rated heat output (warmer climate conditions – Medium temperature)	- kW
Seasonal space heating energy efficiency (colder climate conditions - Low-temperature)	- %
Seasonal space heating energy efficiency (warmer climate conditions - Low-temperature)	- %
Seasonal space heating energy efficiency (colder climate conditions - Medium temperature)	- %
Seasonal space heating energy efficiency (warmer climate conditions - Medium temperature)	- %
Annual energy consumption - final energy (colder climate conditions - Low-temperature)	- kWh
Annual energy consumption - GCV (colder climate conditions - Low-temperature)	- GJ
Annual energy consumption - final energy (warmer climate conditions - Low-temperature)	- kWh
Annual energy consumption- GCV (warmer climate conditions - Low-temperature)	- GJ
Annual energy consumption - final energy (colder climate conditions - Medium temperature)	- kWh
Annual energy consumption - GCV (colder climate conditions - Medium temperature)	- GJ
Annual energy consumption - final energy (warmer climate conditions - Medium temperature)	- kWh
Annual energy consumption- GCV (warmer climate conditions - Medium temperature)	- GJ
Sound power level (Outdoors)	- 52 dB

Model placed on the Union market from 01/12/2024



EPREL registration number: 2222208

EPREL: <https://eprel.ec.europa.eu/screen/product/spaceheaters/2222208>

Supplier: Grant Engineering (Ireland)

Customer care service:

Website: www.grant.eu

Name: Grant R&D Department

Phone: +353 (0)57 91 20089

Email: info@grant.eu

Address:

Barrack Street, Crinkle, Birr,
Co. Offaly, R42 D788, Ireland

14.5 HPR2901160 FICHE

Product Fiche Concerning the COMMISSION DELEGATED REGULATIONS

(EU)No 811/2013 of 18 February 2013

(EU)No 813/2013 of 2 August 2013

Supplier name or trademark	Grant Engineering (Ireland) ULC
Model identifier	Aerona HPR290i160
Seasonal space heating energy efficiency class (average climate conditions - Low-temperature)	A+++
Seasonal space heating energy efficiency class (average climate conditions - medium temperature)	A++
Rated heat output (average climate conditions – Low temperature)	15 kW
Rated heat output (average climate conditions – Medium temperature)	14 kW
Seasonal space heating energy efficiency (average climate conditions - Low-temperature)	182 %
Seasonal space heating energy efficiency (average climate conditions - Medium temperature)	133 %
Annual energy consumption - final energy (average climate conditions - Low-temperature)	6 605 kWh
Annual energy consumption - GCV (average climate conditions - Low-temperature)	- GJ
Annual energy consumption - final energy (average climate conditions - Medium temperature)	8 805 kWh
Annual energy consumption - GCV (average climate conditions - Medium temperature)	- GJ
Sound power level (Indoors)	- dB
Specific precautions	All specific precautions for assembly, installation and maintenance are described in the operating and installation instructions. Read and follow the operating and installation instructions.
Additional information	
Rated heat output (colder climate conditions - Low-temperature)	- kW
Rated heat output (warmer climate conditions - Low temperature)	- kW
Rated heat output (colder climate conditions – Medium temperature)	- kW
Rated heat output (warmer climate conditions – Medium temperature)	- kW
Seasonal space heating energy efficiency (colder climate conditions - Low-temperature)	- %
Seasonal space heating energy efficiency (warmer climate conditions - Low-temperature)	- %
Seasonal space heating energy efficiency (colder climate conditions - Medium temperature)	- %
Seasonal space heating energy efficiency (warmer climate conditions - Medium temperature)	- %
Annual energy consumption - final energy (colder climate conditions - Low-temperature)	- kWh
Annual energy consumption - GCV (colder climate conditions - Low-temperature)	- GJ
Annual energy consumption - final energy (warmer climate conditions - Low-temperature)	- kWh
Annual energy consumption- GCV (warmer climate conditions - Low-temperature)	- GJ
Annual energy consumption - final energy (colder climate conditions - Medium temperature)	- kWh
Annual energy consumption - GCV (colder climate conditions - Medium temperature)	- GJ
Annual energy consumption - final energy (warmer climate conditions - Medium temperature)	- kWh
Annual energy consumption- GCV (warmer climate conditions - Medium temperature)	- GJ
Sound power level (Outdoors)	- 53 dB

Model placed on the Union market from 01/12/2024



EPREL registration number: 2222219

EPREL: <https://eprel.ec.europa.eu/screen/product/spaceheaters/2222219>

Supplier: Grant Engineering (Ireland)

Website: www.grant.eu

Customer care service:

Phone: +353 (0)57 91 20089

Name: Grant R&D Department

Email: info@grant.eu

Address:
Barrack Street, Crinkle, Birr,
Co. Offaly, R42 D788, Ireland

15 HEALTH & SAFETY INFORMATION

15.1 GENERAL

Under the Consumer Protection Act 1987 and Section 6 of the Health and Safety at Work Act 1974, we are required to provide information on substances hazardous to health (COSHH Regulations 1988).

Adhesives, sealants and paints used in the manufacture of the product are cured and present no known hazards when used in the manner for which they are intended.

! WARNING !

Isolate the heat pump from the electricity supply before removing any covers.

15.2 REFRIGERANT (R290)

The Grant Aerona R290 series units contain R290 hydrocarbon refrigerant gas with a 99.5% purity. The density of this gas is greater than that of air, so in the event of leakage it tends to disperse and stratify, accumulating in niches, depressions in the ground or underground regions.

The refrigerant circuit is hermetically sealed within the heat pump.

Work involving the refrigerant must only be performed by a qualified F-Gas Engineer or an authorised dealer with a refrigerant handling certificate.

Under no circumstances should the refrigerant be vented or otherwise released to the atmosphere. If the gas escapes suddenly from the refrigeration circuit, it will immediately cool to -45°C, causing frostbite to unprotected skin.

Whilst R290 refrigerant gas is not toxic, it is an asphyxiant.

R290 refrigerant gas is extremely flammable (Category 1) with sparks from static discharge causing ignition. A high flame velocity leaves a high potential for explosion.

! WARNING !

The use of silicon sealant may inhibit the effectiveness of some types of leak detection equipment

15.2.1 FIRST AID MEASURES

INHALATION

In low concentrations may cause narcotic effects. Symptoms may include dizziness, headache, nausea and loss of co-ordination.

In high concentrations may cause asphyxiation. Symptoms may include loss of mobility/consciousness. Victim may not be aware of asphyxiation.

Remove victim to uncontaminated area wearing self contained breathing apparatus. Keep victim warm and rested. Seek urgent medical advice.

Apply artificial respiration if breathing stopped.

SKIN/EYE CONTACT

In case of frostbite spray with water for at least 15 minutes. Apply a sterile dressing.

Immediately flush eyes thoroughly with water for at least 15 minutes.

Remove contaminated clothing. Drench affected area with water for at least 15 minutes.

Obtain medical assistance

INGESTION

Ingestion is not considered a potential route of exposure.

16 DISPOSAL AND RECYCLING

GENERAL

Grant air source heat pumps incorporate components manufactured from a variety of different materials. However, most of these materials cannot be recycled as they are contaminated by the refrigerant and oil used in the heat pump.

DECOMMISSIONING

Before carrying out this procedure, it is essential that the technician is completely familiar with the heat pump and all its details. It is recommended good practice that all refrigerants are recovered safely. Prior to the task being carried out, an oil and refrigerant sample shall be taken.

It is essential that electrical power is available before the task is commenced. .

- a. Become familiar with the equipment and its operation.
- b. Isolate system electrically
- c. Before attempting the procedure ensure that:
 - Mechanical handling equipment is available, if required, for handling refrigerant cylinders.
 - All personal protective equipment is available and being used correctly.
 - The recovery process is supervised at all times by a competent person.
 - Recovery equipment and cylinders conform to the appropriate standards.

RECYCLING

In order for the heat pump to be recycled or disposed of it must be taken to a suitably licensed waste facility. You will need to contact a qualified refrigeration engineer to do this for you.

When removing refrigerant from a system, either for decommissioning, it is recommended good practice that all refrigerants are removed safely.

When transferring refrigerant into cylinders, ensure that only appropriate refrigerant recovery cylinders are employed.

- Ensure that the correct numbers of cylinders for holding the total system charge are available.
- All cylinders to be used are designated for the recovered refrigerant and labelled for that refrigerant (i.e special cylinders for the recovery of refrigerant).
- Cylinders shall be complete with pressure relief valve and associated shut-off valves in good working order.
- Empty recovery cylinders are evacuated and, if possible, cooled before recovery occurs.

- The recovery equipment shall be in good working order with a set of instructions concerning the equipment that is at hand and shall be suitable for the recovery of flammable refrigerants.
- In addition, a set of calibrated weighing scales shall be available and in good working order.
- Hoses shall be complete with leak-free disconnect couplings and in good condition. Before using the recovery machine, check that it is in satisfactory working order, has been properly maintained and that any associated electrical components are sealed to prevent ignition in the event of a refrigerant release.
- Consult manufacturer if in doubt.

DISPOSAL

The refrigerant will be removed and returned to the refrigerant manufacturer for recycling or disposal.

The complete heat pump unit, including the compressor and the oil contained within it, must be disposed of at a licensed waste facility, as it still remains contaminated by the refrigerant.

- The recovered refrigerant shall be returned to the refrigerant supplier in the correct recovery cylinder, and the relevant Waste Transfer Note arranged.
- Do not mix refrigerants in recovery units and especially not in cylinders.
- If compressors or compressor oils are to be removed, ensure that they have been evacuated to an acceptable level to make certain that flammable refrigerant does not remain within the lubricant.
- The evacuation process shall be carried out prior to returning the compressor to the suppliers.
- Only electric heating to the compressor body shall be employed to accelerate this process.
- When oil is drained from a system, it shall be carried out safely.

17 GUARANTEE

You are now the proud owner of an Air Source Heat Pump from Grant Engineering which has been designed to give years of reliable, trouble free, operation.

Grant Engineering guarantees the manufacture of the heat pump including all electrical and mechanical components for a period of twelve months from the date of installation⁴, provided that the air source heat pump has been installed in full accordance with the installation and operating instructions issued.

This will be extended to a total period of five years if the air source heat pump is commissioned and registered with Grant. This does not affect your statutory rights. within thirty days of installation⁴ and it is serviced at twelve monthly intervals³. See main Terms and Conditions below.

If a fault or defect occurs within the manufacturer's guarantee period

Contact your installer or service engineer to ensure that the fault does not lie with the system components or any incorrect setting of the system controls that falls outside of the manufacturer's guarantee otherwise a service charge could result. Grant Engineering will not be liable for any charges arising from this process.

If a fault covered by the manufacturer's guarantee is found

Ask your installer to contact Grant Engineering Service Department on +353 (0)57 91 20089 who will arrange for a competent service engineer to attend to the fault.

Remember - before you contact Grant Engineering

- Ensure the air source heat pump has been installed, commissioned and serviced by a competent person in accordance with the installation and operating instructions.
- Ensure the problem is not being caused by the heating system or any controls not supplied by Grant Engineering.

Free of charge repairs

During the first two year guarantee period no charge for parts or labour will be made, provided that the air source heat pump has been installed and commissioned correctly in accordance with the manufacturer's installation and operating instructions, it was registered with Grant Engineering within thirty days of installation⁴ and, for air source heat pumps over twelve months old, details of annual service is available³. Years 3, 4 and 5 of the heat pump are covered with parts only warranty, provided the unit has been serviced as detailed each 12 month period. There is no labour cover for this period.

The following documents must be made available to Grant Engineering on request:

- Proof of purchase
- Commissioning Report Form
- Service documents
- System Design Criteria

Chargeable repairs

A charge may be made (if necessary following testing of parts) if the cause of the breakdown is due to any fault(s) caused by the

plumbing or heating system, e.g. contamination of parts due to system contamination, sludge, scale, debris or trapped air. See 'Extent of manufacturer's guarantee' below.

Extent of manufacturer's guarantee:

The manufacturer's guarantee does NOT cover the following:

- If the air source heat pump has been installed for over five years, any replacement parts are not covered.
- If the air source heat pump has been installed for over two years, the callout and labour cost are not included
- If the air source heat pump has not been installed, commissioned, or serviced by a competent person in accordance with the installation and operating instructions.
- The serial number has been removed or made illegible.
- Fault(s) due to accidental damage, tampering, unauthorised adjustment, neglect, misuse or operating the air source heat pump contrary to the manufacturer's installation and operating instructions.
- Damage due to external causes such as bad weather conditions (flood, storms, lightning), fire, explosion, accident or theft.
- Fault(s) due to incorrectly sized expansion vessel(s), incorrect vessel charge pressure or inadequate expansion on the system.
- Fault(s) caused by external electrics and external components not supplied by Grant Engineering.
- Air source heat pump servicing, de-scaling or flushing.
- Checking and replenishing system pressure.
- Electrical cables and plugs, external controls not supplied by Grant Engineering.
- Heating system components, such as radiators, pipes, fittings, pumps and valves not supplied by Grant Engineering.
- Instances where the heat pump has been un-installed and re-installed in another location.
- Use of spare parts not authorised by Grant Engineering.
- Consumable items including, but not limited to, corrosion and biocide inhibitor.
- Damage caused as a direct result of an antifreeze valve discharging.
- Faults due to incorrectly installed antifreeze valves or inadequate discharge during antifreeze valve activation.
- The cost and provision of any specialist access equipment, or any associated costs, required to inspect, repair, service or replace any units not installed in accordance with these installation instructions, irrespective of whether the heat pump is deemed to be at fault or not.

Terms of manufacturer's guarantee

- The Company shall mean Grant Engineering (Ireland) ULC.
- The heat pump must be installed by a competent installer and in full accordance with the relevant Codes of Practice, Regulations and Legislation in force at the time of installation.
- The heat pump is guaranteed for two years from the date of installation⁴, providing that after twelve months the annual service has been completed³ and the heat pump registered with the Company within thirty days of the installation date⁴. Any work undertaken must be authorised by the Company and carried out by a competent service engineer.
- If the air source heat pump has been installed for over five years, any replacement parts are not covered
- The internal heat exchanger of the heat pump is also covered by a **two year parts and labour** guarantee from the date of installation⁴. This is subject to the following:
 - The heat pump is operated correctly, in accordance with the installation and operating instructions.
 - Proof is provided that the system has been flushed or chemically cleaned where appropriate (refer to BS 7593)

and that the required quantity of a suitable corrosion inhibitor added.

- Proof of annual servicing (including the checking of any expansion vessels and pressure relief valves) must be provided if and when requested by the Company.
IMPORTANT Grant Engineering **strongly recommends** that a Grant Mag-One Duo in-line magnetic filter/s (or equivalent⁵) is fitted in the heating system pipework. This should be installed and regularly serviced in accordance with the filter manufacturer's instructions.
- This guarantee does not cover breakdowns caused by incorrect installation, neglect, misuse, accident or failure to operate the heat pump in accordance with the manufacturer's installation and operating instructions.
- The heat pump is registered with the Company within thirty days of installation. Failure to do so does not affect your statutory rights¹.
- The balance of the guarantee is transferable providing the installation is serviced prior to the dwelling's new owners taking up residence. Grant Engineering must be informed of the new owner's details.
- The Company will endeavour to provide prompt service in the unlikely event of a problem occurring, but cannot be held responsible for any consequences of delay however caused.
- This guarantee applies to Grant Engineering air source heat pumps purchased and installed in the Republic of Ireland and Northern Ireland only. Provision of in-guarantee cover elsewhere in the is subject to agreement with the Company.
- All claims under this guarantee must be made to the Company prior to any work being undertaken. Invoices for call out/repair work by any third party will not be accepted unless previously authorised by the Company.
- Proof of purchase and date of installation, commissioning and service documents must be provided on request.
- If a replacement heat pump is supplied under the guarantee (due to a manufacturing fault) the product guarantee continues from the installation date of the original heat pump, and not from the installation date of the replacement⁴.
- The replacement of a heat pump under this guarantee does not include any consequential costs.

18 USER INSTRUCTIONS

18.1 USER INSTRUCTIONS

These instructions are intended to assist the user with the operation of a Grant Aerona R290 air source heat pump. Full details on the Installation, Commissioning and Servicing of the heat pump are contained in these Installation and Operating Instructions.

This appliance can be used by children aged from 8 years and above and persons with reduced physical, sensory or mental capabilities or lack of experience and knowledge if they have been given supervision or instruction concerning use of the appliance in a safe way and understand the hazards involved. Children shall not play with the appliance. Cleaning and user maintenance shall not be made by children without supervision.

18.2 ABOUT YOUR HEAT PUMP

Your Grant Aerona R290 air source heat pump is a highly efficient and fully automatic unit that extracts heat energy from the outside air to heat your home.

The Grant Aerona R290 is an 'air to water' heat pump. In operation, the fan (or fans) draws air through the finned coil evaporating the refrigerant in the heat pump. This refrigerant is then compressed to increase its heat energy before it passes through a heat exchanger transferring that heat energy to the water of your heating system.

Your Grant heat pump is designed to work at lower system operating temperatures than traditional oil or gas fired boilers. Radiators will therefore feel cooler to the touch, but this should not cause a problem with the heating of your house. The system will have been designed to work at these lower temperatures and the heat pump will be set to ensure the correct comfort levels are maintained.

Underfloor heating systems will require a longer pre-heat period to bring the floor up to operating temperature.

The heat pump has been designed to be as efficient as possible and will operate at a 'set point' temperature depending on conditions inside and outside of your house. Due to this, your radiators will be warmer some days and cooler others. This is normal and the heat pump is working correctly.

18.3 AERONA SMART CONTROLLER

Your heat pump will be fitted with a Grant Aerona Smart Controller. This will be electrically connected to the heat pump outside, but will be located in a convenient position within your home.

The principle functions of the Grant Aerona Smart Controller are:

- To enable the heat pump operating parameters to be accessed and adjusted as required by the heat pump installer.
- To manage installed system devices where appropriate for DHW priority, Anti-Legionella protection & supplementary heating.
- To provide simple to use heating and hot water scheduling.
- To provide both the user and installer remote access to the controller for remote control & diagnostics via ecoNET24.

The heat pump is supplied with the operating parameters set to the factory default values. However, these parameter settings should have been checked by the installer when the heat pump

was commissioned and adjusted where necessary to ensure they are correctly set to suit your particular installation.

These heat pump operating parameters should NOT then be altered other than by either the installer or a Grant Service Engineer if and when necessary.

The Smart Controller touchscreen will display both the outside air temperature and inside air temperature (for the area where the remote controller is located) and, if configured, will perform real time adjustments to the heat pump output temperatures

For further information on the operation and configuration of user settings, refer to Section 7 of your supplied manual:

- DOC 0203 - for systems without Grant pre-plumbed cylinder
- DOC 0205 - for systems with Grant Smart pre-plumbed cylinder

18.4 POWERING HEAT PUMP ON/OFF

18.4.1 POWERING HEAT PUMP ON FROM YOUR CONTROLLER

To switch the heat pump ON:

1. First, check the power supply to the heat pump is switch ON at the weatherproof isolator. This is usually located outside next to the heat pump.
2. Check the Aerona Smart is also powered ON.
For further information on the powering on the Smart controller, refer to your supplied manual:
 - DOC 0034 - smart heat pump system controller
 - DOC 0033 - for systems with Grant Smart standard and pre-plumbed cylinder.
3. Tap the 'Heat pump schematic' from the touchscreen display. Refer to Figure 18-1.

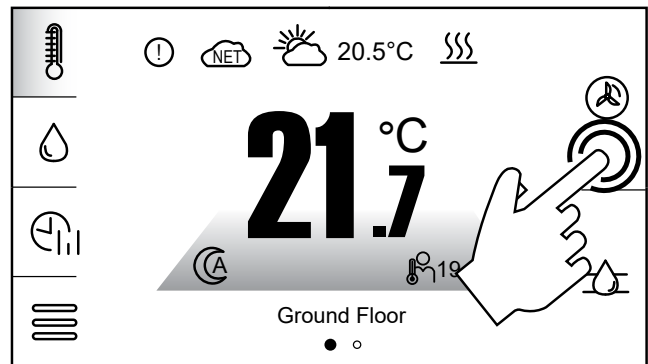

Figure 18-1: accessing HP

4. Tap the 'work mode' icon on the touchscreen display. Refer to Figure 18-2.

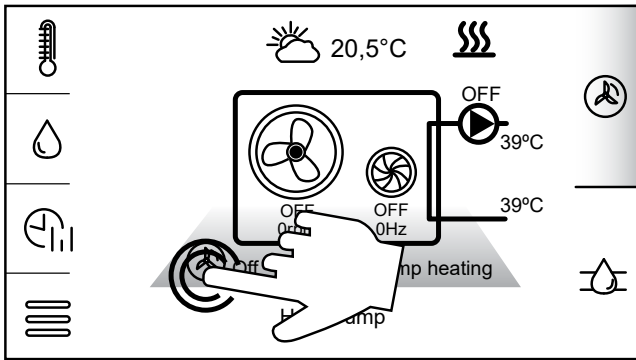

Figure 18-2: access Heat pump work mode

- Tap 'ON'. If you tap 'SCHEDULE' the heat pump will be ON/OFF based on the schedule which can be set. Refer to Table 18-1.

Table 18-1: Heat Pump Status

 ON	The heat pump is turned on.
 OFF	The heat pump is turned off regardless of the conditions in the system.
 SCHEDULE	The heat pump is switched on and off according to the set time schedule for the heat pump.

18.4.2 POWERING HEAT PUMP OFF FROM YOUR CONTROLLER

To switch the heat pump OFF:

- Follow the steps in 18.4.1 to step 5, and tap 'OFF'.

18.4.3 POWERING HEAT PUMP ON/OFF MANUALLY

To switch the heat pump off: Switch the external electrical isolator to OFF.

! NOTE !

This isolator is usually located on the outside wall of your house next to the heat pump.

To switch the heat pump back on: Switch the external electrical isolator back to ON.

! CAUTION !

If the electrical supply to the heat pump is switched off, e.g. at the external isolator, the frost protection function will NOT operate.

In order for the heat pump to start (when it is switched ON) there must also be a 'demand' from the heating system controls. Refer to the Section 18.6 'Heating System Controls' section of these User Instructions.

18.5 AERONA SMART CONTROLLER DISPLAY

The operation of the Grant Aerona R290 heat pump is indicated in the top right of the touchscreen display. The red 3 wavy lines symbol indicates there is a 'demand' being communicated to the heat pump from the smart controller.

To view real time information on the status of the heat pump follow steps 1-3 in section 18.4.1 to access the 'heat pump schematic' screen. This displays active information from the heat pump such as fan, pump & compressor status and water temperatures.

18.6 HEATING SYSTEM CONTROLS

Your Grant Aerona R290 heat pump is controlled by the Grant Aerona Smart Controller and is designed to provide:

18.6.1 SPACE HEATING

The Grant Aerona Smart controller is designed to manage up to 3 space heating zones, where a user can specify set schedules for Day (occupied) or night (unoccupied) time periods.

The space heating can be managed by:

- Thermostats - This allows the required air temperature to be set. When the air temperature is below this setting the thermostat will 'call' for the heat pump to operate to provide heating. This is usually located in a downstairs area such as a hallway or living room, but you may have more than one room thermostat if your heating system is 'zoned'.
- Fixed Water temperatures - The 'zone' (circuit) is set with a fixed temperature. When the schedule comes 'ON', it will 'call' for the heat pump which delivers a set fixed output (flow) temperature for the 'circuit'.
- Weather compensation - The 'Zone' (circuit) is set with a climatic curve, which measures the outdoor (ambient) air temperature against a desired output (flow) temperature when the heating schedule is 'ON' and 'calling' the heat pump 'ON'.

! NOTE !

For the heat pump to operate to provide heating, the schedule must be in an ON period for heating AND the room thermostat must be 'calling'.

For further information on the operation and configuration of space heating zone settings, refer to Section 7 of your supplied manual:

- DOC 0034 - smart heat pump system controller
- DOC 0033 - for systems with Grant Smart standard and pre-plumbed cylinder.

18.6.2 HOT WATER

In addition to heating zones, the Grant Aerona Smart controller is designed to manage a hot water cylinder, where a user can specify both schedules for 'ON' and 'OFF' time period for heat to be provided and desired water temperature with the aid of a cylinder water temperature sensor.

The installer should discuss and configure the desired temperature of the hot water and a level deemed too low requiring more heat (hysteresis).

When the schedule for the hot water is ON, if the cylinder temperature difference is greater than the 'hysteresis' value:

- The heat pump will be 'called' to provide heat for your hot water cylinder.
- The Smart controller will shut off any active space heating zones, and divert all heat generated to your cylinder. This is known as "Hot water priority".
- The heat pump will stay ON until your cylinder has reached it's set temperature.
- 'Hot water priority' will then be disabled, starting your space heating zones.

! NOTE !

If your cylinder falls below the 'hysteresis' level again within a scheduled ON time period, 'Hot water priority' will re-engage.

For further information on the operation and configuration of hot water cylinder settings, refer to Section 7 of your supplied manual:

- DOC 0034 - smart heat pump system controller
- DOC 0033 - for systems with Grant Smart standard and pre-plumbed cylinder.

18.7 ANTI-LEGIONELLA PROTECTION

Your Grant Aeron Smart Controller is designed with the ability control and schedule Anti-Legionella protection for your DHW cylinder. The Smart controller will activate the cylinder immersion heater to aid your heat pump in periodically raising the water temperature in the cylinder to 60°C to prevent Legionella bacteria on a weekly basis.

For further information on the operation and configuration of hot water cylinder settings, refer to your supplied manual:

- DOC 0034 - smart heat pump system controller
- DOC 0033 - for systems with Grant Smart standard and pre-plumbed cylinder.

18.8 FROST PROTECTION

Your Grant Aeron R290 heat pump is fitted with automatic frost protection functions for various heat pump components that will operate when either the outside air temperature and the system water temperatures fall to a pre-set value (6°C).

This frost protection function will operate even when the heat pump is switched OFF at the Smart controller. See Section 18.4 of these User Instructions.

As the heat pump frost protection involves the operation of the circulating pump, it is perfectly normal to hear the circulating pump running (when the heat pump is off) during periods of cold weather.

Under low ambient air conditions the water pump may operate repeatedly to provide frost protection when the heat pump is not operating, e.g. possibly throughout the night, until the heat pump starts the following morning. The cost to protect the heat pump from freezing in this way is small due to the low water pump power consumption.

18.9 LOOKING AFTER YOUR HEAT PUMP

Grant Aeron R290 Heat Pumps require very little maintenance but it is important that the air inlet grilles (at the rear and left-hand side of the unit) are kept clear at all times.

Also, ensure that the fan outlet grille is unobstructed at all times.

Remove any build-up of leaves, snow or any other debris from the air inlet and outlet grilles.

! CAUTION !

Do not either

- **Stack anything (e.g. garden furniture, bicycles, etc.) either on or against your heat pump.**
- **Do not place any cover over the unit.**

In the case of any construction work, e.g. grinding, sanding, cutting, etc, where a lot of dust is created, the unit should be switched off and covered until the work is finished

- Do not place any objects or equipment on the top of the unit
- Do not climb, sit or stand on the top of the unit.

To ensure that it continues to operate efficiently your Grant Aeron R290 heat pump should be serviced annually, as detailed in Section 10 of the Installation Instructions supplied with the unit. Contact your installer or service engineer to carry out this work.

18.10 TROUBLESHOOTING

If your heat pump fails to operate:

First check:	Is the power supply is switched ON at the external isolator?
If YES:	Check that the heat pump is switched ON at the controller. Refer to the 'Section 18.3 of these User Instructions.
If YES:	Check if there is a demand from the heating system controls. Refer to the 'Heating System Controls' section of these User Instructions.
If YES:	If your heating zones are weather regulated, the outdoor temperature may be too high to 'call' the heat pump on.
If YES:	Check the display on the controller. Is an error displayed?
If YES:	What is the error code shown? Refer to Section 11 of the Installation and Operating Instructions supplied with the heat pump for a full list of the error codes. Contact your installer or service engineer for assistance.

APPENDIX A CIRCULATION PUMP GPA25-9HW

A.1 CIRCULATION PUMP GPA25-9HW PWM PUMP

Table A-1: GPA25-9HW specifications

Feature	Specification
Nominal supply voltage	EU: 1 x 230V +10% / -15%, 50/60 Hz
EEL Rating	≤0.21-Part3
Motor protection	The motor is protected by the electronics in the control box and requires no external motor protection
Protection class	IPX4D (standard without drain holes)
EMC Standards	EN 61000-6-1 EN 61000-6-3
Insulation class	H (EN 60335-1)
Temperature class	TF95
Maximum Flow (m ³ /h)	4.5
Connection (inches)	1½ - 1 BSPM
Operational range	2 to +95°C
High voltage protection	EN 60335-1 1000V AC
Ambient temperature Range	0 to +75°C
Maximum media temperature	+125°C
Minimum media temperature	2°C (IPX4D: above dew point of ambient air).
Storage temperature	0°C to +55°C
Minimum inlet pressure <75°C	0.05 MPa (0.50 bar) @ 0.5m head
System pressure	0.3MPa (3 bar)
Maximum system pressure	1 MPa (10 bar)
Rated Condition (m @ m ³ /h)	6.5 @ 2.5
Relative humidity	Maximum 95%, non-condensing environment
Acoustic sound pressure level (LP)	≤ 42 dB(A)

! CAUTION !

Ensure the system is filled to required system pressure prior to the heat pump being powered on. The pump should not be run dry.

! CAUTION !

Ensure to isolate and drain down the heat pump before attempting any maintenance or repair.

A.1.1 PWM PUMP

The pump is controlled by the Grant Aeron 290 via a PWM signal that controls the speed by an ON/OFF and feedback to maintain the required flow for the circuit.

Flow management devices such as flow regulators or restrictors should not be used and all valves should be fully open. The PWM pump will automatically attempt to compensate against and restrictions to water flow which could lead to excessive wear and energy usage.

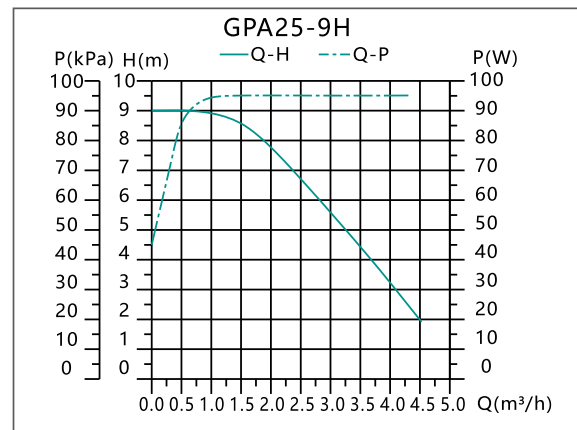

Figure A-1: Pump performance

! CAUTION !

System flow temperature should always be higher than ambient temperature to avoid condensate on the pump.

A.2 PUMP INTERFACE

The pump control panel will indicate various operational states from the 2 indicator LED. Refer to Figure A-2 and Table A-3 for LED.

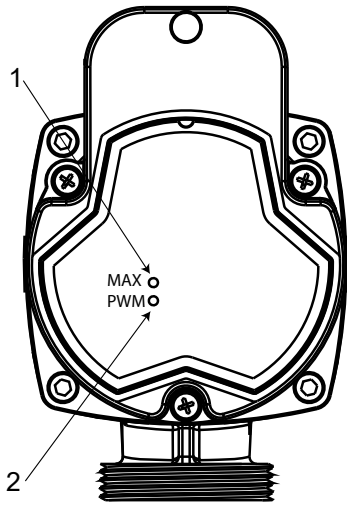

Figure A-2: Pump control panel

Table A-3: Pump control panel

Item	Description
1 (MAX)	Maximum pump RPM/PWM Feedback reached

2 (PWM)	PWM Signal active
---------	-------------------

The LED indicators will flash to indicate faults. Refer to Table A-4.

Table A-4: Pump Faults

Number of flashes	Fault description
1	When the voltage is between 265V and 275V, the pump will stop working, and the pump is at the over-voltage protection model. When the voltage is abnormal, the pump will re-start working.
2	When the voltage is between 160V and 170V, the pump will stop working, and the pump is at the under-voltage protection model. When the voltage is abnormal, the pump will re-start working.
3	Over-current protection, re-start the pump after 5s.
4	Light-load protection, re-start the pump after 5s.
5	Phase loss protection, re-start the pump after 5s.
6	Block protection, re-start the pump after 5s.
7	Over-temperature protection, re-start the pump after ambient temperature resumes to operation range.

After the fault is displayed, you will need to isolate the power supply before attempting to troubleshoot further, When complete power the Aerona 290 on to restart.

Table A-5: Pump fault diagnosis

Fault	Cause	Action
Pump fails to start	Fuse is burnt out	Replace fuse
	Connection to PCB is loose or disconnects	Reconnect pump to Hydraulic PCB
	Pump failure	Replace the pump
	Too low voltage	Check power supply is within required range
	Pump rotors are stuck	Remove impurities
System noise	Gas in the system	Ensure automatic air purge valve is functional
	Excess flow	Reduce inlet water pressure
Noise in the pump	Gas in the pump	Ensure automatic air purge valve is functional
	Inlet pressure too low	Increase inlet water pressure
Reduced heat output of Aerona R290	Poor pump performance	Increase inlet water pressure

ONLINE RESOURCES

AERONA SMART CONTROLLER - HOW TO PLAYLIST

QR CODE	DESCRIPTION
	<p>How to video guides playlist for the Grant Aerona Smart Controller.</p> <p>The playlist offers a number of helpful guides on how to set individual elements of the Grant Aerona Smart controller and is monitored and updated to ensure the best possible assistance is available.</p> <p>Can't find something specific? Email info@grant.ie or contact your local sales representative for further assistance.</p>

SERVICE LOG

Service 1	Date
	Engineer
	Company name
	Telephone number
	Comments
	Signature

Service 5	Date
	Engineer
	Company name
	Telephone number
	Comments
	Signature

Service 2	Date
	Engineer
	Company name
	Telephone number
	Comments
	Signature

Service 6	Date
	Engineer
	Company name
	OFTEC Technician number
	Comments
	Signature

Service 3	Date
	Engineer
	Company name
	Telephone number
	Comments
	Signature

Service 7	Date
	Engineer
	Company name
	Telephone number
	Comments
	Signature

Service 4	Date
	Engineer
	Company name
	Telephone number
	Comments
	Signature

Service 8	Date
	Engineer
	Company name
	Telephone number
	Comments
	Signature

Service 9	Date
	Engineer
	Company name
	Telephone number
	Comments
	Signature

Service 13	Date
	Engineer
	Company name
	Telephone number
	Comments
	Signature

Service 10	Date
	Engineer
	Company name
	Telephone number
	Comments
	Signature

Service 14	Date
	Engineer
	Company name
	Telephone number
	Comments
	Signature

Service 11	Date
	Engineer
	Company name
	Telephone number
	Comments
	Signature

Service 15	Date
	Engineer
	Company name
	Telephone number
	Comments
	Signature

Service 12	Date
	Engineer
	Company name
	Telephone number
	Comments
	Signature

Service 16	Date
	Engineer
	Company name
	Telephone number
	Comments
	Signature



GRANT ENGINEERING (IRELAND) ULC

Crinkle, Birr, Co. Offaly, R42 D788, Ireland

Tel: +353 (0)57 91 20089

Email: info@grant.ie www.grant.eu