

Grant Energy Management Control Systems

Includes weather compensation, sequence controllers, low loss headers and zone pumps



Reduces heating bills • Environmentally friendly • Header systems suitable for systems up to 165kW
Individually controlled heat circuits • Maximises overall boiler/appliance efficiency • Allows multiple heating appliances to be combined
Tailored system concept drawings for both plumbing and wiring available • 5-year product guarantee



Grant Profile

At Grant we have been designing and manufacturing reliable and easy to install heating products for over 35 years. From award winning oil-fired condensing boilers to the latest renewable technologies, our heating systems have a reputation for quality that is second to none.

We combine precision engineering, innovation, performance and value for money to produce sustainable heating solutions that are trusted by both installers and householders.



Quality Design

There is never a compromise on quality. We design all of our products so that you can be sure that the durability and efficiency are sector leading. We continually develop new technologies and use only the best materials to ensure our products meet all performance and environmental standards.

Our belief in simple solutions ensures that, while our technology is sophisticated, our products are low maintenance and easy to install. For a high quality, reliable and sustainable heating system, trust in Grant.

Heating Responsibly

Grant manufacture heating products that respond to the challenges of rising fuel costs whilst protecting our environment. Environmental responsibility is central to all we do and we continue to develop and innovate to produce even more efficient products that make best use of our natural resources.

We are passionate about developing sustainable, high-performance and affordable alternatives for heating homes into the future.

Our Guarantee

The Grant label is a guarantee of reliability, quality and value. We put our customers first and our independence ensures that we can monitor our standards and processes to deliver the very best quality and service.

That's why, when you order your system from a Grant stockist, you can be sure of a tailored service and excellent aftersales support.

Why choose a Grant Control System?

Fuel prices are increasing year on year and this is having a major impact on home heating costs. Although the price of fuel cannot be changed, steps can be taken to reduce the amount used.

Heating controls hugely affect system performance and efficiency. The correct control system not only makes it easier to maintain a more comfortable temperature within the home, but it keeps heating bills and CO₂ emissions down by using less fuel.

Grant has a range of individual control solutions that cleverly work together to enable heating systems to operate at optimal efficiency, ensuring householders get the best out of their system. These include, weather compensation, sequence controllers, zone pumps and low loss headers. The systems are suitable for individual dwellings, properties with several zones, installations with multiple heat sources or a combination of different heating technologies.

Features:

- Reduces heating bills
- Easier system installation and commissioning
- Environmentally friendly
- Suitable for systems up to 165kW
- Individually controlled heat circuits
- Option to switch the system to hot water priority
- Allows a number of heating appliances to be combined, including renewable technologies
- Provides boiler lead/lag rotation, equalising appliance running times
- Maximises overall boiler/appliance efficiency
- Tailored system concept drawings for both plumbing and wiring available

Grant GEO360 Weather Compensator

Systems without weather compensation The GEO360

When air temperatures in the house fall below the setting on the room thermostat, a signal is sent for the boiler to fire and warm the house.

Unfortunately a disadvantage of this simple arrangement is that the thermostat only tells the boiler to turn on or off when the house is too cold or too hot, respectively. Some systems are even installed without a room thermostat (boiler interlock), relying solely on individual thermostatic radiator valves.

In either case no consideration is given to maintaining the correct flow and return temperatures that enable a boiler to operate in condensing mode or to any external temperature fluctuations.

Systems with weather compensation

Boiler flow and return temperatures will be monitored and controlled, and the system can react promptly to internal and external air temperature changes.

Autumn

- Room thermostat calls for heat on a cool autumn night
- A signal is sent for the control to turn the boiler on and warm the house
- Control uses the outdoor temperature to calculate the water temperature required by the system
- Control operates the boiler to allow the system to heat up to that temperature (using less fuel)

Winter

- Room thermostat calls for heat on a cold winter day/night
- A signal is sent from the control to turn the boiler on and warm the house
- Control uses the outdoor temperature to calculate the water temperature required. This will be higher in colder weather
- Control operates the boiler to maximum and modulates the heating system to the desired temperature

The GEO360 (Grant Efficiency Optimiser) is a smart control system comprising of a controller, two pipe thermostats together with an internal and external air sensor, coupled to a mixing valve.



With the information retrieved through the outdoor air sensor (fitted on a north facing wall) the unit can adjust system water temperature to match a heat output closer to the needs of the home. In fact, the system will adapt before it even feels too cold or too hot. In periods of warm weather the GEO360 will automatically shut the system down until it is needed again.

Flow and return temperatures can be pre-set on the control module enabling condensing boilers to operate in condensing mode more often, thereby saving fuel and making the system more environmentally friendly.

The GEO360 monitors weather conditions throughout the year regardless of the season. Without the control unit, a heating system does not know if it is a cool autumn night or the coldest winter day. Therefore it works as if it was always the coldest day of the year and heats the system water to a maximum temperature.

Simple system incorporating a GEO360 weather compensator

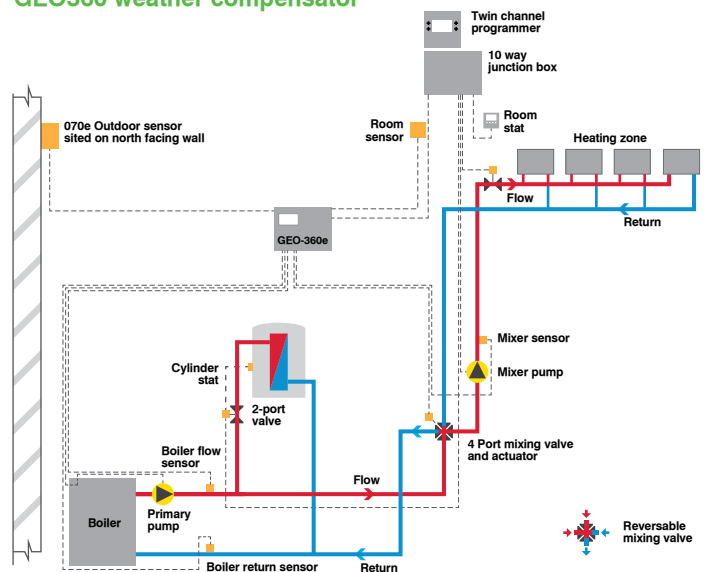

Concept drawing only
- not site specific

Grant GES264 Sequence Controller

Benefits of a Sequence Controller

The Grant 264 sequence controller is designed to manage from 2 to 4 heat sources. These may include renewable technologies such as air source heat pumps and wood pellet boilers or alternatively oil/gas boilers. The controller is able to cope with a mix of fuels all at the same time. This is achieved by using a common flow sensor and using the heat sources installed to satisfy the demand.

The water temperature may be weather compensated and used with or without hot water priority, depending on the pipework layout, pumps and motorised valve set up.

When controlling up to 4 appliances the controller will record the time run for every heat source/boiler and rotate the firing sequence to provide an equal burn time for all units. This will ensure that all appliances share the load throughout the year.

When firing takes place each unit will only run when required, depending on the load placed on the system. This ensures maximum efficiency and prevents unnecessary firing and wasted energy.

Depending on the system design and layout it is possible to include pump overrun. Primary and hot water pumps can also be controlled by the controller.

When used in conjunction with a buffer/thermal store the weather compensation facility will be disabled as the store would be kept at a constant temperature. The control recognises this as a set point temperature and is preset at commissioning along with a check of all other parameters.



Simple low loss header system incorporating 2x heat pumps and 2x zones

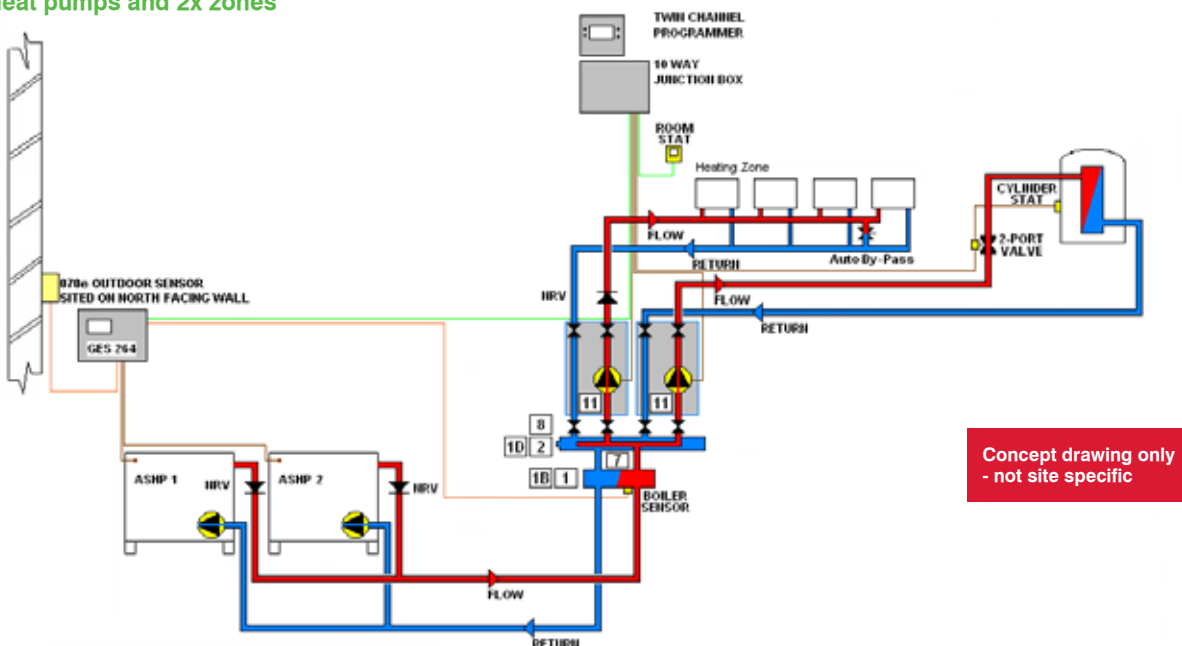

Grant Low-loss Headers

Feeding Heating Zones

Header systems are a cost effective way of installing multiple heat sources and feeding more than one heating zone which have different temperature requirements. This is achieved by using a small low loss header known as a hydraulic switcher and a distributor.



Depending on the system load, two sizes are available (up to 70kW and up to 165kW @ Δt 20 °C flow and return set up temperature). The heating appliances are then connected to the switcher, which provides an open circuit for the appliance system water to feed the heating distribution header. This can be supplied with 2 to 6 Grant zone pump kits for each heating and hot water circuit, as required.

The Grant low loss header provides the installer and the customer with a professional installation which is both cost effective to install and run.

Technical Specification	70kW Header
Maximum flowrate	up to 3m ³ /h, 6bar
Distribution Header	110 x 110 x 508mm (min) - 1508mm (max) (depending on model)
Zone Pump Kit	1" male
Hydraulic switcher connection	1 1/4" male
Side connection	3/4" female

Technical Specification	165kW Header
Maximum flowrate	up to 7m ³ /h, 6bar
Distribution header	152 x 152 x 625mm (min) - 1625 (max) (depending on model)
Pump unit connection	1 1/4" male
Hydraulic switcher connection	2" male
Side connection	2" male



Wall Fixings

The distribution header is fixed to the wall using brackets which are supplied as a pair. The type of brackets required varies depending on the header size (70kW or 165kW).

The brackets for the 70kW system can be used in either of two positions to vary the distance between the wall and the centre line of the header.

Grant Zone Pump Kits

System Circulation

Zone pump kits are available in two sizes, each with both constant temperature and variable temperature options. A variable temperature option (including a mixing valve and actuator) is used where weather compensation, using a Grant GEO360, is required.

The kits are designed to sit vertically on the header unit with a fully insulated compact black cover which house the high efficiency circulating pump and valves. The flow and return valves are colour coded to show flow and return with large dial handles with a thermostat dial, giving a clear indication of heating activity.

The variable temperature kit shown below has an additional mixing valve which is adjusted by a servomotor to mix the flow temperature to the heating circuit. The servomotor and valve respond to the sensors fitted to the GEO360 weather compensator to give the correct comfort level to the property. A non return valve is also supplied to prevent reverse circulation, see



Constant temperature



Variable temperature

Zone Pump Kit - Constant Temperature

Comprises	Zone pump, isolator ball valves, temperature gauges and non-return valve
Connections	1" (70kW header) and 1 1/4" (165kW header)
Dimensions	250 x 380 x 190mm
Maximum temperature	110 °C
Application	35kW max @ $\Delta T = 20^\circ C$ 1500l/h
High efficiency pump	6m, 8m - 70kW 7m, 8m - 165kW

Zone Pump Kit - Variable Temperature

Comprises	Mixing valve and actuator
Connections	1" (70kW header) and 1 1/4" (165kW header)
Dimensions	250 x 380 x 190mm
Maximum temperature	110 °C
Application	35kW max @ $\Delta T = 20^\circ C$ 1500l/h
High efficiency pump	6m, 8m - 70kW 7m, 8m - 165kW

Grant System Component Identification

System incorporating 6x zones (70kW) low loss header system with 2x boilers

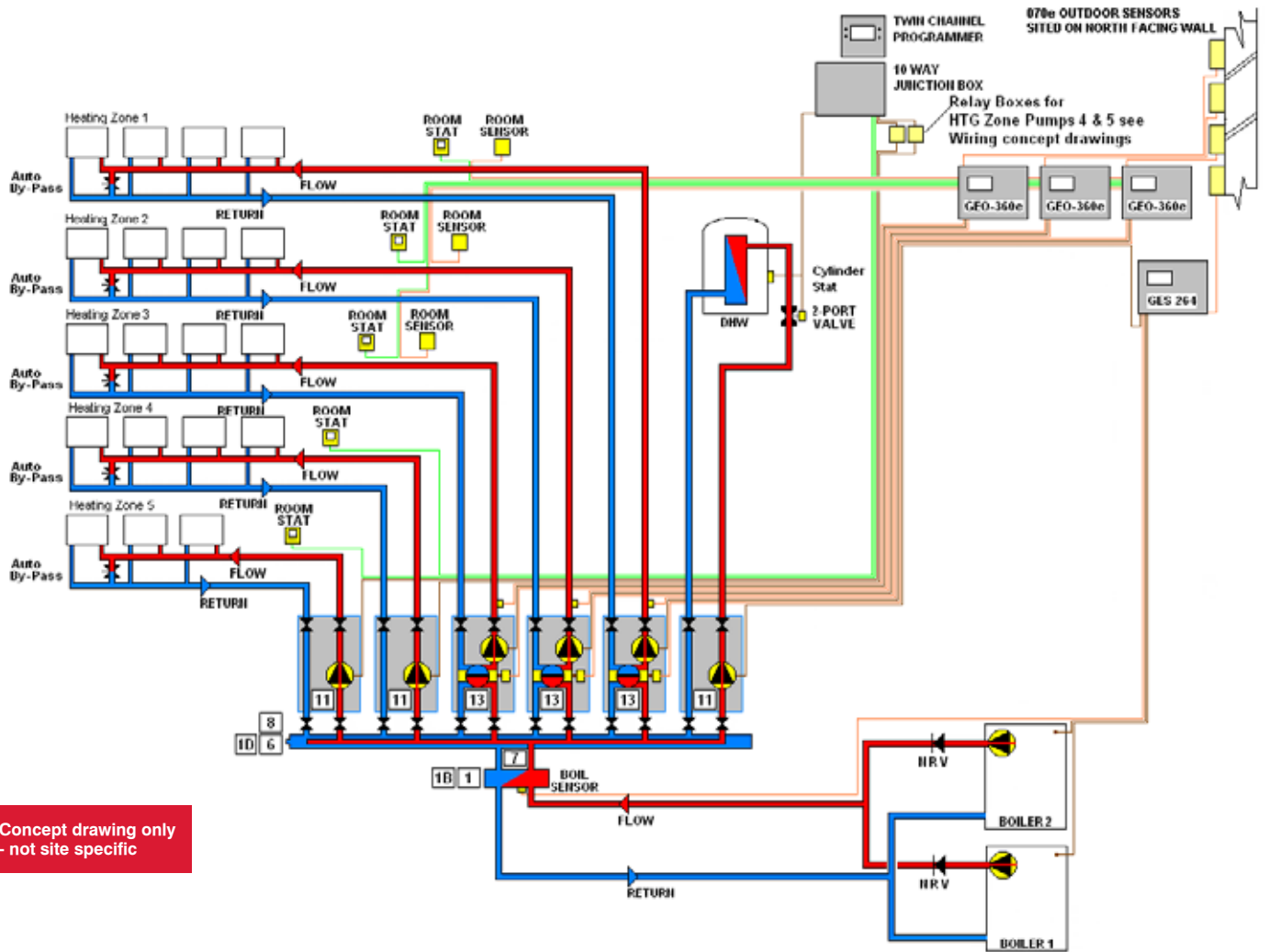

Concept drawing only
- not site specific

Diagram references

Draw No.	Part description	Further information	Product code
1	1 1/4" Hydraulic switcher – 70kW	Note: 70kW @ 20°Δt	GHS60/125
1B	Header bracket set wrap over 100mm	Only 1 set per header required	GHS/WF100
1C	Header bracket set wrap over 150mm	Only 1 set per header required	GHS/WF150
1D	Header bracket set 90°	Only 1 set per header required	GHS/WFHV
2	1" F&R Distributor*		GHS70/1252
3	1" F&R Distributor*	2–6 is the number of pump units (circuits) per installation as required by the installer (see drawings).	GHS70/1253
4	1" F&R Distributor*		GHS70/1254
5	1" F&R Distributor*		GHS70/1255
6	1" F&R Distributor		GHS70/1256
7	1 1/4" connector	2 connectors per switcher	GHS05629
8	1" valves	2 valves per pump station	GHS/0266M
11	Constant temperature 6m zone pump kit	Constant temp, variable speed for heating hot water primary circuits	GHS/CT01
12	Constant temperature 8m zone pump kit*		GHS/CT02
13	Variable temperature 6m zone pump kit	For heating circuits only. With mixing valve used with GEO360 w/comp	GHS/VT03
14	Variable temperature 8m zone pump kit*		GHS/VT04
15	GES264 sequence controller	Up to 4 boiler sequence controller & weather compensation	GES264
16	GEO360	Weather compensator	GHS/GEO360

* Note: component not shown on illustration

There is also a 165kW system. For more detail contact our design team on +44 (0)1380 736920

Grant Concept System

Alternative use of energy management controls

This layout shows a system incorporating a ThermaWave thermal store, linking a number of different technologies such as an oil boiler, 2 air source heat pumps, a solar thermal system, a GES264 sequence controller and a GEO360 weather compensator.

ErP Package uplift

In addition to increasing the overall efficiency of the heating system, by incorporating a GES264 controller or GEO360 optimiser, you will also benefit from an increase in efficiency under the Energy Related Products Directive (ErP) by up to 4%. For example, a heating system using a Vortex Pro 15-21kW, a Sahara 2 panel solar kit and a 300lt DuoWave cylinder would have a package rating of A. Incorporate a GEO360 and the package rating will increase to A+.

System with thermal store incorporating a number of heat sources

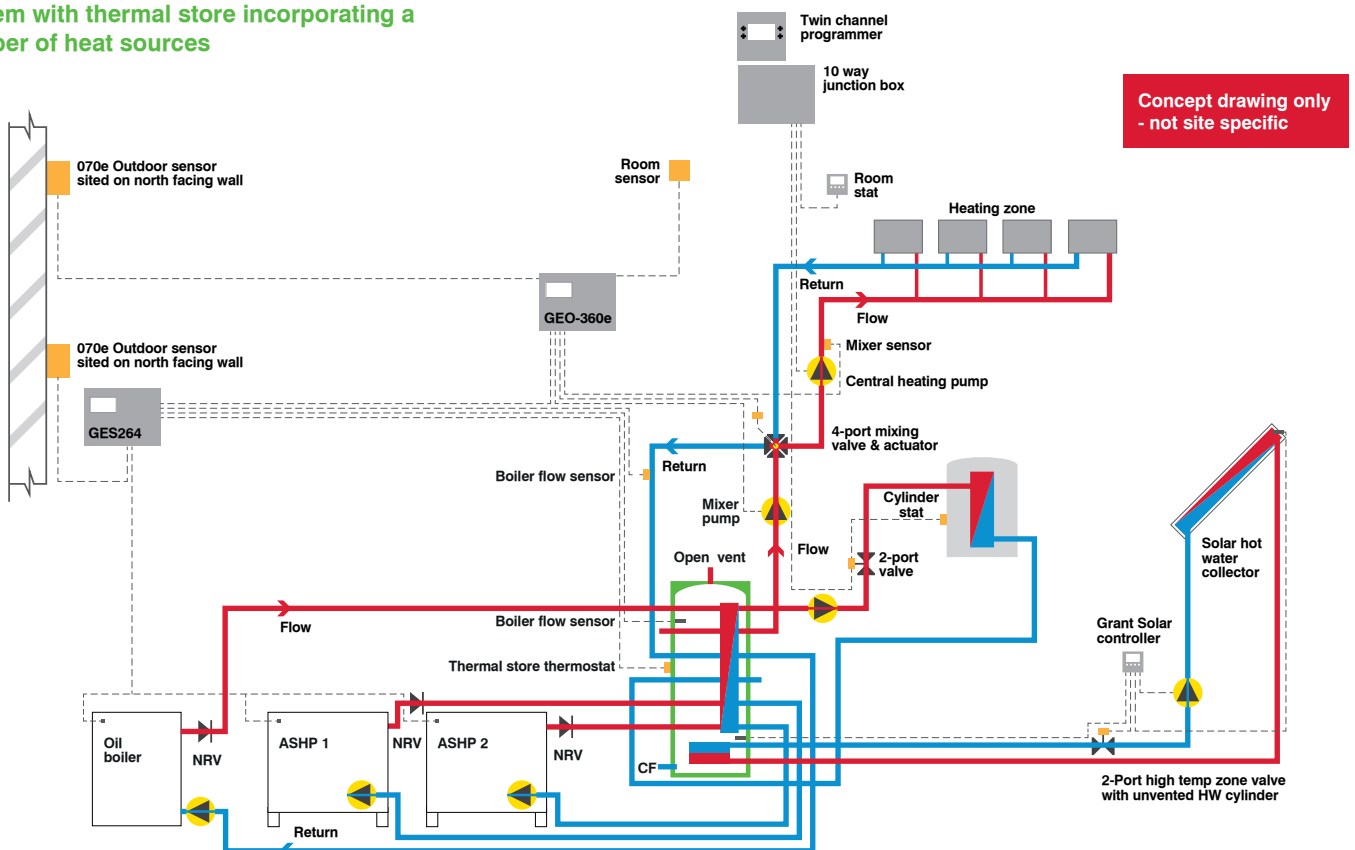

Installation

Improper installation and operation of Grant control systems could result in damage to the equipment and possibly even personal injury. It is the installer's responsibility to ensure that the parts are safely installed to all applicable codes and standards.

Aftersales service

For peace of mind, all Grant control systems are backed by a national network of independent service engineers. In the unlikely event of a problem occurring, the installer should telephone our Customer Service Department on: +44 (0)1380 736920.

Guarantees

Grant Energy Management Control Systems are covered by a 1 year guarantee from the date of purchase (2 years if registered within 30 days), subject to being installed in accordance with the Manufacturer's instructions. On completion of the installation the system must be commissioned and the guarantee registration form completed online.

Training Academy

At our purpose built Training Academy in Devizes we offer a wide range of training courses, including Grant product training courses, OFTEC training and assessment and Logic Certification courses. Our facilities include air-conditioned lecture rooms and extensive oil burner and 'renewables' training and assessment workshops. Here our trainees can hone their skills on a full size training roof, working solar thermal and wood pellet boilers, controls, air source heat pumps, thermal store installations, solar thermal training/assessment rigs and unvented hot water training and assessment rigs.

For further information call: +44 (0)1380 736943

Website downloads

For further information about the Grant product range or to download our brochures please visit our website at: www.grantuk.com





Grant Engineering (UK) Ltd

Hopton House, Hopton Industrial Estate,
Devizes, Wiltshire, SN10 2EU

t: +44 (0)1380 736920 f: +44 (0)1380 736991
e: sales@grantuk.com w: www.grantuk.com



This leaflet is accurate at the time of printing but as Grant UK has a policy of continual improvement it may be superseded. We reserve the right to amend specifications without prior notice. The statutory rights of the consumer are not affected.

All products manufactured under I.S. EN ISO 9001. Grant UK additionally holds ISO 14001 accreditation.

™ THE GRANT 'EZ-FIT FLUE' SYSTEM is a trade mark of Grant Engineering Limited.

©Grant Aeron, Grant Spira, Grant Vecta, Grant Biovac, Grant SpiraPod, Grant Vortex, Grant Solar, Grant Aurora, Grant Sahara, Grant CombiSOL, Grant WinterSOL, Grant MonoWave, Grant DuoWave, Grant ThermaWave, Euroflame and Multi Pass are registered trade marks of Grant Engineering Limited. The contents of this leaflet are fully protected by copyright and nothing may be reproduced without permission from Grant UK.