

# Grant DuoWave System

Solar Cylinder Ranges

## Installation & User Instructions



Part No. IRL 20. Rev 00. June 2011

Do not fit on a well or borehole supply

# Contents

<b>1</b>	<b>Introduction &amp; General Requirements</b>	<b>3</b>	<b>5</b>	<b>Electrical Installation</b>	<b>11</b>
1.1	Installation Requirements	3	5.1	Immersion Heater	11
1.2	Water Supply Requirements	3	5.2	Immersion Heater Wiring Instructions	11
1.3	Location	3	5.3	Dual Thermostat	11
1.4	Storage and Handling	3	5.4	2-Port Valve	11
1.5	About Your New Cylinder	3	5.5	Y-plan System	12
1.6	Open Vented Hot Water Systems	3	5.6	S-plan System	13
1.7	Taps and Fittings	3	5.7	Solar Thermal System	14
1.8	Pipework Connections	3			
1.9	Scaling	3	<b>6</b>	<b>Commissioning, Draining Down &amp; Safety</b>	<b>15</b>
1.10	Insulation	3	6.1	Filling Cylinder	15
1.11	Health and Safety	3	6.2	Draining Down	15
<b>2</b>	<b>Technical Specifications</b>	<b>4</b>	6.3	Safety Cut-Out	15
2.1	Technical Data - DuoWave Solar	4	6.4	Cold Water Discharge from Tundish	15
2.2	Connections and Controls	5	6.5	Hot Water Discharge from Tundish	15
<b>3</b>	<b>Primary Circuit Installation</b>	<b>7</b>	6.6	Expansion Vessel	15
3.1	Grant DuoWave Solar Cylinders	7	6.7	Customer Handover	15
3.2	Systems	7	<b>7</b>	<b>Maintenance</b>	<b>16</b>
3.3	Primary Connections	7	7.1	Servicing and Maintenance	16
3.4	The 2-Port Valve	7	7.2	Manifold Assembly	16
3.5	Auxiliary Primary Connections	7	7.3	Pressure Reducing Valve	16
3.6	Hard Water Areas	7	7.4	Expansion Relief Valve Cartridge	16
<b>4</b>	<b>Secondary Circuit Installation</b>	<b>8</b>	7.5	Expansion Vessel	16
4.1	Cold Water Inlet Manifold	8	<b>8</b>	<b>Fault Finding</b>	<b>17</b>
4.2	Installation	8	8.1	Intermittent Water Discharge	17
4.3	Expansion Vessel	8	8.2	Constant Water Discharge	18
4.4	Temperature and Pressure Relief Valve	8	8.3	No Flow from Hot water Taps	18
4.5	Hot Water Supply	8	8.4	Cold Water Flow from Hot Water Taps	19
4.6	Prevention of Scalding	8	8.5	Excessive Hot Water from Taps	20
4.7	Secondary Return	9	<b>9</b>	<b>Spare Parts</b>	<b>21</b>
4.8	Tundish	9	9.1	Spare Parts	21
4.9	Discharge Pipe	10	<b>10</b>	<b>User Instructions</b>	<b>22</b>
4.10	Discharge Pipe Arrangement	10	10.1	User Instructions	22
4.11	Discharge Pipe Sizing	10	<b>11</b>	<b>Warranty</b>	<b>23</b>
4.12	Worked Example	10	11.1	The Grant Cylinder Warranty	23

# 1 Introduction & General Requirements

## 1.1 Installation Requirements

Thank you for purchasing a Grant unvented hot water storage cylinder from our Wave range. This installation manual must be read carefully before you begin installing the cylinder.

This cylinder must be installed by a competent person in compliance with all current legislation, codes of practice and local by-laws covering the installation of an unvented hot water cylinder. Please also make sure that any installation complies with the instructions contained in this installation instruction manual.

## 1.2 Water Supply Requirements

We recommend that your Grant Unvented cylinder is installed with an uninterrupted water supply.

Where possible the unit should be fed via a Ø22mm supply pipe. It requires a supply pressure of 1.5bar with a flow rate of at least 20 litres per minute as a minimum for it to function. Even with these rates, flow from the outlets will be disappointing if several outlets are used simultaneously. Generally speaking, the higher the supply pressure, the better the incoming system will function. The cylinder control equipment is factory set to limit the incoming system operating pressure to 3bar. The maximum supply pressure into the pressure-reducing valve (PRV) is 12bar.

## 1.3 Location

The unit is designed to be floor standing, vertically mounted, indoors, in a frost-free environment. When choosing a suitable location for the cylinder, consideration should be given to the routing of the discharge pipe to a convenient point and also the availability of an adequate power supply for connecting the immersion heater.

The cylinder may stand on any flat and level surface without any special foundation preparations, provided that it is sufficiently robust to support the full weight of the cylinder. (Refer to Technical specifications for weights).

The position of the cylinder should be such that easy access is provided for servicing the controls and replacing the immersion heater should the need arise.

Generally, pipe runs should be made as short as possible and lagged to prevent heat loss.

## 1.4 Storage and Handling

If the cylinder is not being installed immediately, it should remain in its carton to prevent damage. We recommend that the cylinder be transported to its installation position on a sack truck or similar whilst still within the carton.

## 1.5 About Your New Cylinder

DuoWave Solar indirect cylinders have two coils for connection to Primary heat sources. For Solar Thermal to be connected, the bottom coil must be used. Please refer to the manufacturers installation instructions for more information.

The central heating connections should be made to the top coil.

DuoWave Solar indirect cylinders are also supplied fitted with a single 3kW electric immersion heater.

Refer to page 11 for further details on immersion heaters.

More information on electrical wiring is given on pages 11-14.

## 1.6 Open Vented Hot Water Systems

If required, your Grant DuoWave Cylinder can be used as part of an Open Vented hot water system, i.e. fed from a cold water storage cistern and fitted with an Open Vent pipe, provided the maximum head does not exceed 30m.

When used in this way, it will not be necessary to install the expansion vessel and cold inlet manifold supplied with the cylinder.

### Note:

The Temperature and Pressure relief (T&P) valve should be left connected to the cylinder (as supplied). As it may still operate due to temperature it should be connected in the correct manner – refer to guidance given in Section 4 of these Instructions.

## 1.7 Taps and Fittings

All taps and fittings incorporated in the unvented system should have a rated operating pressure of 7 bar or above.

## 1.8 Pipework Connections

All Pipework connections to the cylinder **must** be made in accordance with Figures 2-4 to 2-6 as appropriate.

## 1.9 Scaling

In hard water areas scaling will form inside the cylinder and this will reduce both the performance and working life of the cylinder. Where the total hardness exceeds 125ppm a high capacity water softener, or suitable water conditioner, should be installed in the incoming cold water supply to the cylinder.

It is recommended that the water temperature control thermostats (on the immersion heaters and dual thermostats) fitted to the cylinder be set no higher than 60°C to minimise scale build up.

## 1.10 Insulation

All Grant Cylinders are insulated with 40mm thick CFC/HFC free, fire retardant, polyurethane foam injected between the stainless steel cylinder and the outer casing. This polyurethane foam has a Global Warming Potential (GWP) of less than 3 and an Ozone Depletion Potential (ODP) of 0.

## 1.11 Health and Safety

The information supplied in the table in Section 2 Technical Specification will help you assess the safest way to manoeuvre your cylinder into position. Please use the table to find the empty weight of your cylinder and then consider how you can safely move it into its final position.

**Please leave this manual with the householder after installation.**

# 2 Technical Specifications

## 2.1 Technical Data - DuoWave Indirect Solar Cylinders

Cylinder model	DuoWave Indirect Cylinders					
	170	200	250	300	400	500*
Storage capacity (litres)	170	200	250	300	400	500
Overall diameter (mm)	580	580	580	580	580	660
Overall height (mm)	1075	1230	1480	1745	2110	1835
Weight empty (kg) - indirect models	49	53	63	72	92	108
Weight full (kg) - indirect models	219	253	313	372	492	608
Secondary return connection (mm)	22	22	22	22	22	22
Cold feed/hot draw-off connections (mm)	22	22	22	22	22	22
Top/bottom coil connections (mm)	22	22	22	22	22	22
Top coil length (m) - indirect models only	5.70	5.70	5.70	5.70	6.81	8.01
Top coil surface area (m <sup>2</sup> ) - indirect models only	0.52	0.52	0.52	0.52	0.73	1.14
Bottom (solar) coil length (m)	5.70	6.81	8.01 / 6.95*	8.01	11.68	13.90
Bottom (solar) coil surface area (m <sup>2</sup> )	0.52	0.73	1.14 / 1.04*	1.14	1.56	2.00
Top/bottom coil pipe diameter (mm)	22	22	22	22	22	22
Dedicated solar volume Vs (litres) - indirect models	85	100	125	150	200	250
Maximum water supply pressure (bar)	12	12	12	12	12	12
System operating pressure - pre-set (bar)	3	3	3	3	3	3
Expansion vessel charge pressure (bar)	3	3	3	3	3	3
Expansion relief valve pressure (bar)	6	6	6	6	6	6
Temp & pressure relief valve lift pressure (bar)	7	7	7	7	7	7
Temp & pressure relief valve lift temperature (°C)	90	90	90	90	90	90
Maximum primary circuit working pressure (bar)	3	3	3	3	3	3
<b>Performance:</b>						
Top coil rating (kW)	8.50	8.50	8.50	8.50	10.00	16.00
Top coil recovery rate (mins)**	18	20	25	26	25	27
Bottom (solar) coil rating (kW)	8.5	10.0	16.0 / 13.9*	16.0	24.0	27.0
24hr standing loss (kW) - indirect models***	2.04	2.45	2.69	2.71	2.94	3.15
<b>Check list:</b>						
Cylinder assembly 170 litre	1	-	-	-	-	-
Cylinder assembly 200 litre	-	1	-	-	-	-
Cylinder assembly 250 litre	-	-	1	-	-	-
Cylinder assembly 300 litre	-	-	-	1	-	-
Cylinder assembly 400 litre	-	-	-	-	1	-
Cylinder assembly 500 litre	-	-	-	-	-	1
Expansion vessel 19 litre	1	1	-	-	-	-
Expansion vessel 24 litre	-	-	1	1	-	-
Expansion vessel 35 Litre	-	-	-	-	1	-
Expansion vessel 50 Litre	-	-	-	-	-	1
Expansion vessel hose (3/4" BSPF x 3/4" BSPM) c/w washer	1	1	1	1	1	-
Expansion vessel wall bracket and band	1	1	1	1	1	-
Adaptor (1" BSPF x 3/4" BSPM)	-	-	-	-	1	-
Temp & pressure relief valve (7 bar 90°C) factory-fitted	1	1	1	1	1	1
Tundish 15/22mm	1	1	1	1	1	1
Drain cock (1/2" end feed)	1	1	1	1	1	-
Inlet manifold (3 bar pressure reducing valve & 6 bar exp. relief valve)	1	1	1	1	1	1
2-port motorised valve 22mm	1	1	1	1	1	1
Dual thermostat (Control 25-65°C High limit 90°C) - indirect	2	2	2	2	2	2
Immersion heater 3 kW (1 3/4" boss) factory-fitted - indirect	1	1	1	1	1	1

\* DuoWave Indirect only. \*\* Recovery rate is based on 82°C flow @ 0.2l/s over a 50°C temp rise for 75% of contents. \*\*\* Test carried out at 60°C.

## 2.2 Dimensions - DuoWave Indirect Solar Cylinders

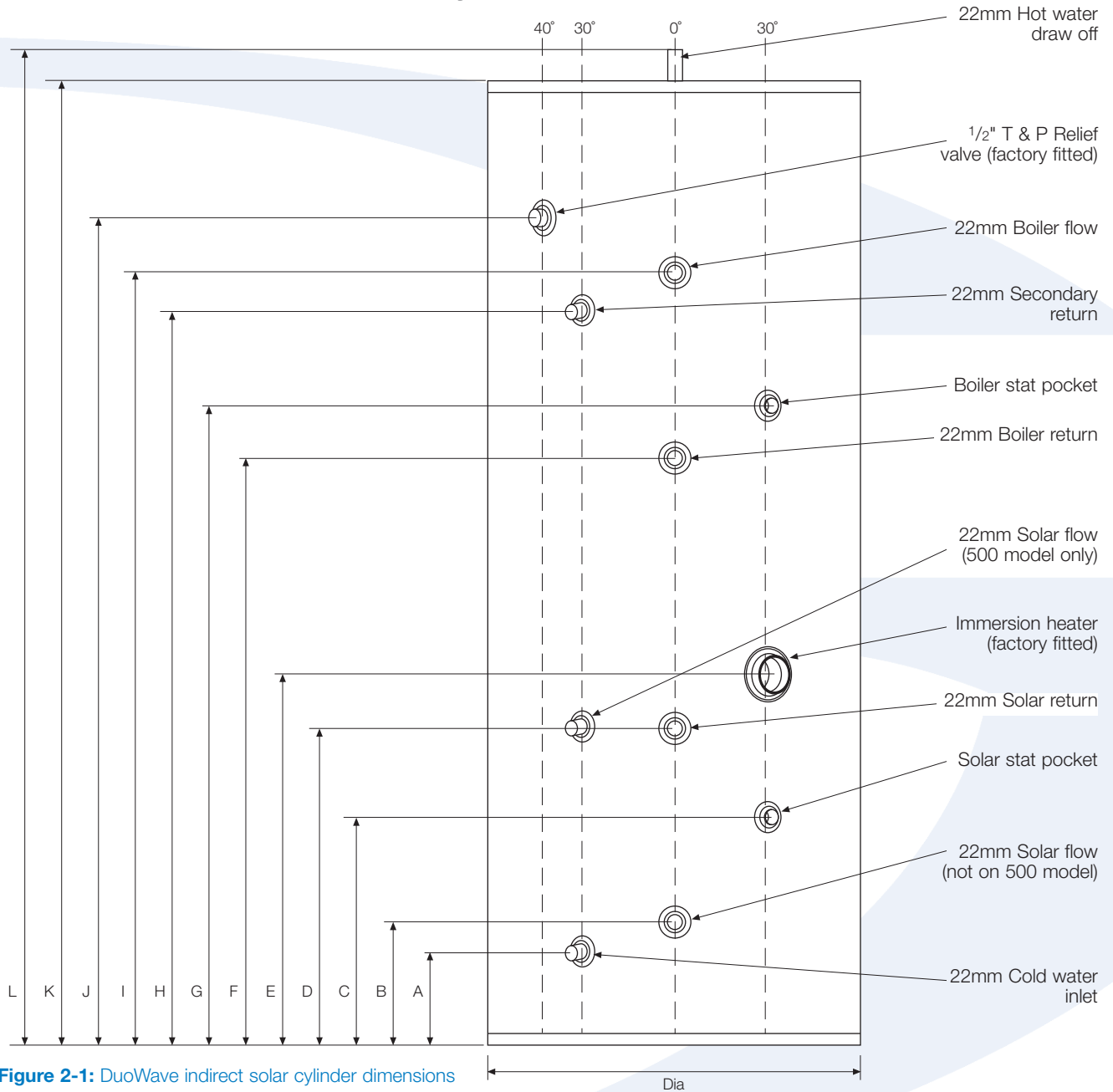

Figure 2-1: DuoWave indirect solar cylinder dimensions

### DuoWave Indirect Solar Cylinder Dimensions

Dims (mm)	Model					
	170	200	250	300	400	500
A	200	200	200	200	200	235
B	275	275	275	320	320	N/A
C	330	330	330	375	400	600
D	380	380	380	420	420	620
E	460	460	460	510	510	715
F	540	660	795	860	1100	820
G	655	790	935	1005	1240	1120
H	735	870	1020	1095	1340	1260
I	795	940	1085	1155	1500	1390
J	800	955	1210	1460	1970	1590
K	1025	1170	1430	1695	2050	1640
L	1075	1230	1480	1745	2110	1835
Dia	580	580	580	580	580	660

# 2 Technical Specifications

## 2.3 Connections and Controls

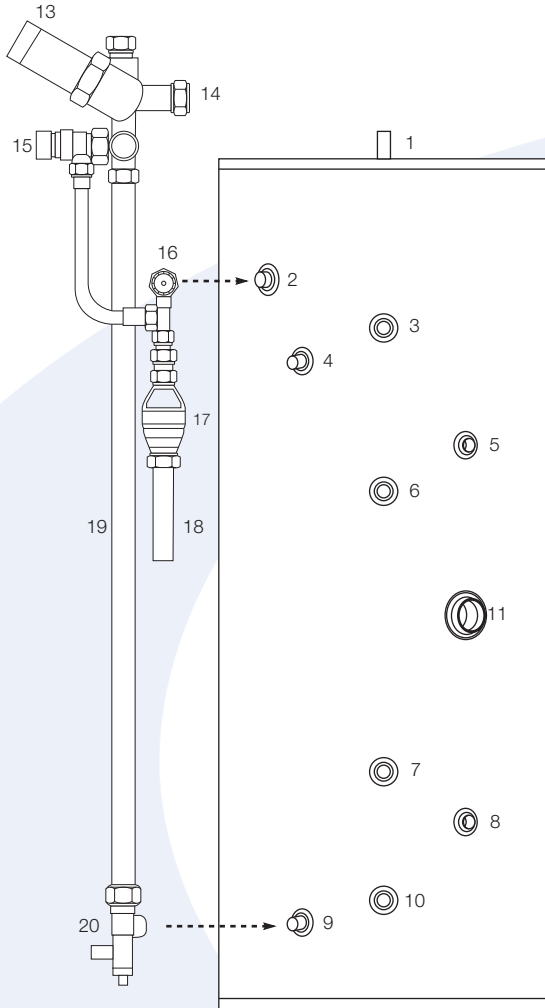

Figure 2-2: DuoWave indirect solar cylinders

Item	Description	Connection Size
1	DHW Out	22mm compression
2	T & P valve connection	1/2" BSPF
3	Boiler return tapping	22mm compression
4	Secondary return tapping	22mm compression
5	Boiler dual thermostat pocket	-
6	Boiler flow tapping	22mm compression
7	Auxiliary (Solar) heat source return tapping	22mm compression
8	Auxiliary (Solar) heat source dual stat pocket (for dual stat only)	-
9	Cold water inlet	22mm compression
10	Auxiliary (Solar) heat source flow tapping	22mm compression
11	Immersion heater c/w control & limit thermostat (factory fitted)	1 3/4" BSPF

Item	Description	Connection Size
13	Pressure reducing valve - 3 bar	-
14	Balanced cold supply connection	22mm compression
15	Expansion relief valve - 6 bar	15mm compression
16	Temperature & Pressure relief valve - 90°C/7 bar	15mm compression
17	Tundish	15/22mm compression
18	Discharge pipe (not supplied with cylinder)	-
19	Mains water supply pipe (not supplied with cylinder)	-
20	Drain cock (supplied with cylinder)	-

**Note:**

Pipework between items 15 and 16 not supplied with cylinder.

# 3 Primary Circuit Installation

## 3.1 Grant DuoWave Solar Cylinders

Grant DuoWave indirect solar cylinders are suitable for connection to most fully pumped domestic gas or oil fired central heating boilers working on an open vented or sealed system having a maximum working pressure of 3 bar and a maximum working temperature of 90°C. **If you are in any doubt over the Suitability of a boiler for use with the cylinder, consult the boiler manufacturer.**

### IMPORTANT

**Solid fuel or wood burning boilers and gravity circulation systems must not be used on the primary circuit of an unvented hot water system.**

## 3.2 Systems

If an existing system is a “flow share” arrangement such as an “S” or “Y” plan type system, (see Figures 5-4, 5-5 and 5-6) they will provide satisfactory results, but during central heating demands, hot water production will not be as responsive.

## 3.3 Primary Connections

1. The primary flow and return connections from the boiler should be made to the upper coil connections of the cylinder.

The motorised valve (supplied) must be fitted into the primary flow. The primary flow and return fittings are 22mm compression. The valve has 22mm compression connections.

2. Locate the dual thermostat in the stainless steel pocket (refer to either Figure 2-1 or 2-3, as appropriate, for location) and secure using the retaining screws on the thermostat housing.
3. Any automatic or manual air vent fitted to vent air from the upper coil should be installed on the primary flow pipe to the coil.

## 3.4 The 2-Port Valve

To prevent gravity circulation when the boiler switches off, the 2-port motorised valve supplied with the unvented hot water kit, must be fitted in the primary flow pipe to the cylinder and wired in accordance with Figures 5-3, 5-5 or 5-7 for boilers (depending on system design).

## 3.5 Auxiliary Primary Connections

### Solar Heating

1. The Solar flow and return connections should be made to the lower coil connections. If the lower coil is not thermostatically controlled a 2-port or solenoid valve (high temperature rated - not supplied) must be fitted in the flow and be controlled from the dual thermostat mounted at low level on the cylinder, via the thermostat pocket (8). Contact Grant Engineering (IRL) Ltd for details.
2. If you are connecting another primary heat source please refer to the installation manual of that appliance. Do not connect an uncontrollable appliance to this cylinder (e.g wood burning stove, multi fuel stove, etc.).

## 3.6 Hard Water Areas

If the cylinder is to be used in a hard water area, we recommend that the primary flow temperature be limited to 75°C. This will help reduce the migration of suspended solids in the water and help prevent the build up of lime scale.

# 4 Secondary Circuit Installation

## 4.1 Cold Water Inlet Manifold

This manifold contains a pressure reducing valve (with integral strainer), double check valve, expansion valve with a stainless steel seat. The pressure reducing valve is factory set. The set pressure is shown on top of the valve. Maximum inlet pressure to valve is 12 bar.

## 4.2 Installation

1. Cold water supply to be 22mm nominal size.
2. **Flush supply pipework before connection to remove all flux and debris prior to fitting the inlet controls. Failure to do this may result in irreparable damage to the controls and will invalidate the warranty. Once the pipework is flushed connect the cold supply to the Inlet manifold.**
3. The manifold can be installed in any position as long as it is installed in the correct flow direction. Refer to the arrows on the side of the body. Make sure that the head of the expansion relief valve is offset from the cylinder for ease of access.
4. The expansion relief valve should be either horizontal or upright - if fitted inverted, debris may be deposited on the seat and cause fouling of the seat when the valve operates. Check direction of flow arrows.
5. The black plastic plug in the body is a pressure gauge connection to enable pressure monitoring to be carried out, should the system develop a fault. It is recommended that this be accessible.

6. Expansion relief drain pipework must be connected to a safe visible discharge point via a tundish and the pipework must have a continuous fall. Connect the Expansion Relief valve outlet into the discharge pipe from the Temperature and Pressure Relief valve using a 15mm copper pipe and tee piece (not supplied). Fit the Tundish below this tee piece using a short length of copper pipe. Refer to Sections 4.7, 4.8 and 4.9 for further information on Tundish and Discharge pipe.
7. The pressure reducing valve has two outlets, the second one is for a balanced cold water supply, to a shower or a bidet (**over rim type only, ascending spray type requires type AA, AB or AD air gap**). **Major shower manufacturers advise fitting a mini expansion vessel in the balanced cold supply to accommodate thermal expansion and prevent tightening of shower controls. If the dwelling has a shower mixing valve (manual or thermostatic) or a Bidet (over rim type) use the cold water supply from the Balanced Cold water connection on the Inlet Manifold for these outlets. Do not use the balanced cold connection to supply bath taps as this can reduce the flow of water available to the cylinder.** If the balanced cold water outlet is not required, blank off the port.

## 4.3 Expansion Vessel

A suitable expansion vessel with a pre-charge pressure of 3bar is supplied for fitting to all cylinders.

The supplied expansion vessel must be connected into the cold water supply between the expansion relief valve (in the inlet manifold) and the cylinder using the flexible hose provided. Flexible hose not supplied with 50 litre expansion vessel. This vessel to be connected using rigid pipe. The expansion vessel must be positioned with the entry point at the bottom. No valve should be fitted between the expansion vessel and cylinder.

The air charge pressure in the expansion vessel must be regularly checked (e.g. at every service) and topped up as necessary. The correct air charge pressure is 3.0bar.

Refer to Sections 7.1 and 7.5 for further details.

## 4.4 Temperature and Pressure Relief Valve

The temperature and pressure relief valve (T&P Valve) is supplied factory fitted to the cylinder. The T&P valve must not be removed from the cylinder or tampered with in any way. The valve is pre-set to lift at 7bar or 90°C and any attempt to adjust it will invalidate the warranty.

## 4.5 Hot Water Supply

1. Connect the hot water supply pipe to the top outlet (1) of the cylinder.

## 4.6 Prevention of Scalding

UK Building Regulations Approved Document G (Part G3) requires that the hot water temperature supplied to a bath should be limited to a maximum of 48°C by using an in-line blending valve (not supplied with the cylinder) with a maximum temperature stop. The length of the supply pipe between the blending valve and the bath hot water outlet should be kept to a minimum to prevent the colonisation of waterborne pathogens (e.g. legionella). Refer to Approved Document G for further details.



## 4.7 Secondary Return

All DuoWave solar cylinders are fitted with a secondary return connection. If a secondary return circuit is required it should be connected to the DuoWave solar cylinder as shown below:

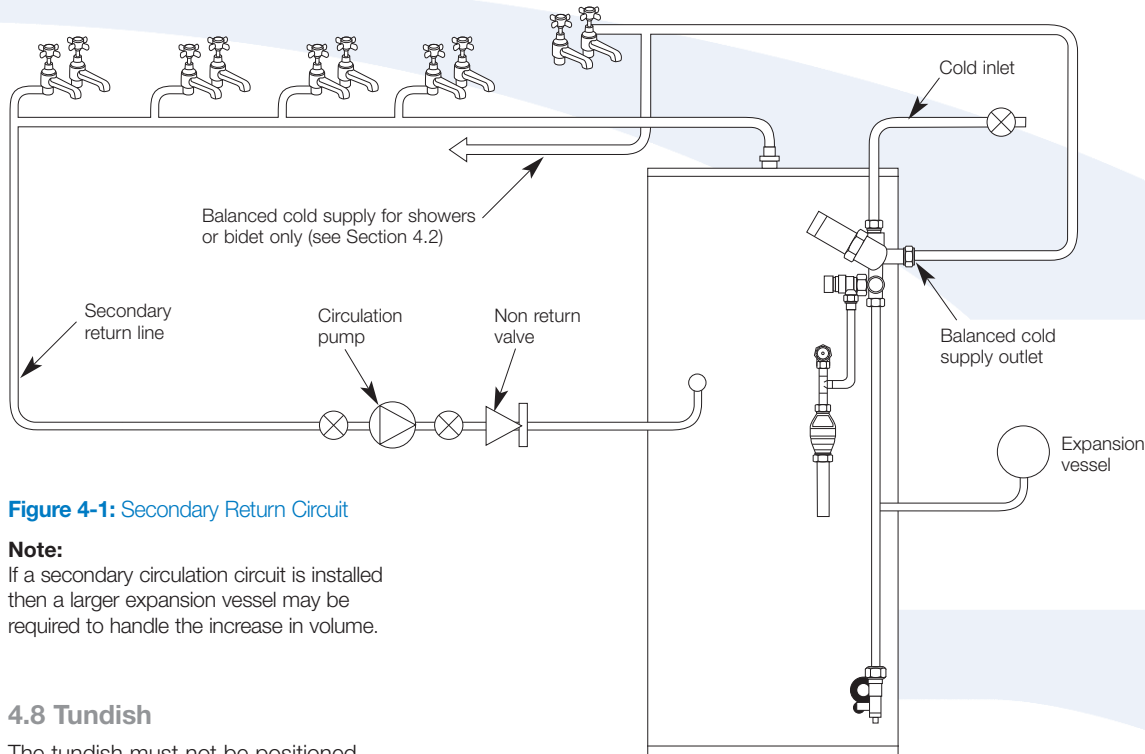

**Figure 4-1: Secondary Return Circuit**

**Note:**

If a secondary circulation circuit is installed then a larger expansion vessel may be required to handle the increase in volume.

## 4.8 Tundish

The tundish must not be positioned above or in close proximity of any electrical current carrying devices or wiring.

## 4.9 Discharge Pipe

1. The discharge pipe from the Tundish should terminate in a safe place where there is no risk to persons in the vicinity of the discharge, be of metal and:
  - a. Be at least one pipe size larger than the normal outlet size of the safety device unless its total equipment hydraulic resistance exceeds that of a straight pipe 9m long, i.e. discharge pipes between 9m and 18m equivalent resistance length should be at least larger than the normal outlet size of the safety device, between 18m and 27m at least three sizes larger and so on. Bends must be taken in to account in calculating the flow resistance. See Sections 4.10, 4.11 and 4.12.
  - b. Have a vertical section of pipe at least 300 mm long, below the tundish before any elbows or bends in the pipe work.
  - c. Be installed with a continuous fall of 1:40 (2.5°).
- d. Have discharges visible at both the tundish and the final point of discharge but where this is not possible or practically difficult there should be clear visibility at one or other of these locations.
2. Examples of acceptance discharge arrangements are:
  - a. ideally below a fixed grating and above the water seal in a trapped gully.
  - b. downward discharges at a low level; i.e. up to 100mm above external surfaces such as car parks, hard standings, grassed areas etc. are acceptable providing that where children may play or otherwise come in to contact with discharges, a wire cage or similar guard is positioned to prevent contact, whilst maintaining visibility.
  - c. discharges at high level; e.g. in to metal hopper and metal down pipe with the end of the discharge pipe clearly visible (tundish visible or not) or onto a roof capable of withstanding high temperature discharges of water and 3m from any plastics guttering systems that would collect such discharges (tundish visible).
3. Where a single pipe serves a number of discharges, such as in blocks of flats, the number served should be limited to not more than 6 systems so that any installation can be traced reasonably easily. The single common discharge pipe should be at least one pipe size larger than the largest individual discharge pipe to be connected. If unvented hot water storage systems are installed where discharges from safety devices may not be apparent i.e. in dwellings occupied by blind, infirm or disabled people, consideration should be given to the installation of an electronically operated device to warn when discharge takes place.

**Note:**

The discharge will consist of scalding water and steam. Asphalt, roofing felt and non-metallic rainwater goods may be damaged by such discharges.

# 4 Secondary Circuit Installation

## 4.10 Discharge Pipe Arrangement

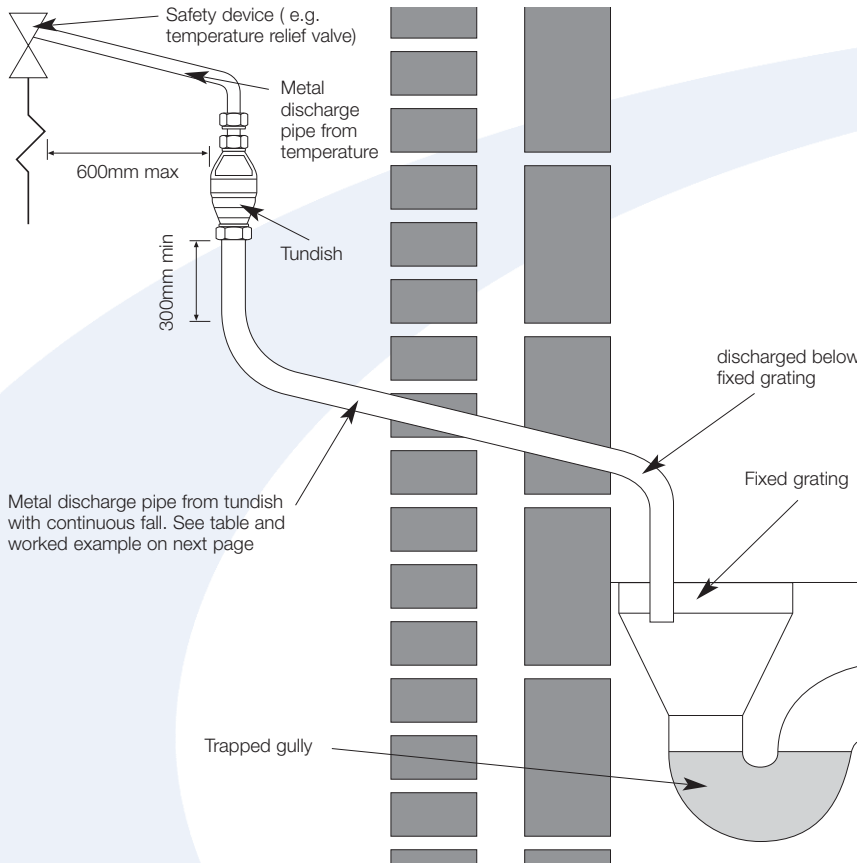

Figure 4-2: Typical discharge pipe arrangement

## 4.11 Discharge Pipe Sizing

Valve outlet size, diameter (inches)	Minimum size of discharge pipe D1 (mm)	Minimum size of discharge pipe D2 from tundish in (mm)	Max resistance allowed, expressed as a length of straight pipe, i.e. no elbows or bends	Resistance created by each elbow or bend in (m)
1/2	15	22	Up to 9	0.8
		28	Up to 18	1.0
		35	Up to 27	1.4
3/4	22	28	Up to 9	1.0
		35	Up to 18	1.4
		42	Up to 27	1.7
1	28	35	Up to 9	1.4
		42	Up to 18	1.7
		54	Up to 27	2.3

## 4.12 Worked Example

The example below is for a 1/2" diameter temperature relief valve with a discharge pipe (D2) having 4 elbows and a length of 7 m from the tundish to the point of discharge.

### From

Maximum resistance allowed for a straight length of Ø22mm copper discharge pipe (D2) from a 1/2" diameter temperature relief valve is - 9.0m.

Subtract the resistance for quantity of 4 Ø22mm elbows at 0.8m each = 3.2m. Therefore, the maximum permitted length equates to 5.8m.

5.8m is less than the actual length of 7m; therefore calculate the next largest size.

Maximum resistance allowed for a straight length of Ø28mm-pipe (D2) from a 1/2" diameter temperature relief valve equates to - 18m.

Subtract the resistance for a quantity of 4 Ø28mm elbows at 1.0 each = 4m.

Therefore the maximum permitted length equates to 14m.

As the actual length is 7m, a Ø28mm diameter copper pipe will be satisfactory.

# 5 Electrical Installation



## WARNING

This appliance **must** be earthed.

All electrical wiring must be carried out by a competent person and in accordance with the **current I.E.E. Wiring Regulations**.

The control equipment supplied will ensure that the cylinder functions safely. From an economic and convenience point of view, it is intended that these controls operate in conjunction with other control packages for example "S", or "Y" plan type systems, which incorporate a programmable time clock, etc.

### 5.1 Immersion Heater

All cylinders are supplied fitted with one immersion heater.

The 3kW 230V 50Hz-immersion heater should be wired in accordance with the instructions given in Figure 5-1.

The cable **must** be routed through the strain relief bush. The control thermostat is pre-set at approximately 60°C. The immersion heater conforms to EEC Directive 76/889 for radio interference and complies with EN 60335-2-73.

Installation and wiring instructions for the immersion heater are supplied with each unit. Follow the wiring instructions connecting the live, neutral and earth as indicated.

The unit must be permanently

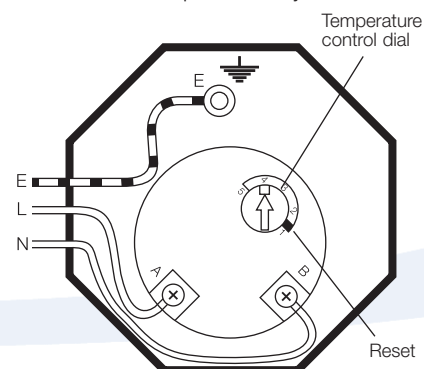

- = Earth (Green/Yellow)
- A = Live (Brown)
- B = Neutral (Blue)

**Figure 5-1: Immersion heater wiring connections**

connected to the electrical supply through a double-pole isolator. A safety cut-out is also incorporated within the thermostat and is factory set to operate at 80°C ± 5°C.

### IMPORTANT

Before resetting the safety cut-out or altering the thermostat setting, isolate electrical supply to the unit prior to removal of the cover. Investigate and identify the cause of the cut-out operation and rectify the fault before manually resetting the cut-out by pressing in the reset button. Ensure the cover to the immersion element is replaced correctly and the retaining nut is fitted. Finally switch the mains electricity supply back on.



## WARNING

The manual re-set high limit thermostat must not under any circumstances be bypassed. This is pre-set to 80°C and to prevent nuisance tripping the control thermostat should always be left in position 4.

### 5.2 Immersion Heater Wiring Instructions

- a) Ensure the main's voltage corresponds to the voltage rating of the immersion heater as shown on the rating label on the terminal cover.
- b) The immersion heater is factory fitted to the cylinder. If the immersion heater needs to be replaced it must be fitted to the cylinder using the gasket provided on the unit. Use a shaped spanner, Stillsons or pipe grips should not be used. The use of sealing compound is not recommended.
- c) Wire the immersion heater in accordance with the wiring diagram (Figure 5-1). It should be wired through a double pole isolator switch or controller, with a minimum break capacity of 13 amp having contact separation of at least 3 mm, using 1.5mm sq. flexible cable, 85°C rubber insulated HOFRR sheathed, to comply with BS 6141 table 8 and must be fully earthed.

- d) The BEAB approval certification on this immersion heater only applies if a Cotherm TSE rod type thermostats is used. The temperature setting of the control thermostat should always be left in position 4.

### 5.3 Dual Thermostat (Indirect Temperature Control)

For the Indirect models two Dual Thermostats (each a combined control and high limit thermostat) are supplied separately with the unvented hot water safety kit. One is fitted into the upper sensor pocket in the cylinder (see Figures 2-4 to 2-6 for position) to control the operation of the boiler or primary coil. The second is fitted in the lower sensor pocket to control the operation of the Solar coil.

The control thermostat has an adjustment range between 25°C and 65°C, however it is recommended that it is set to 60°C. The overheat thermostat incorporated within the dual thermostat will operate at 90°C.

### 5.4 2-Port Valve

To comply with regulations governing the installation of indirect unvented cylinders, a 2-port motorised valve must be fitted in the primary flow to prevent gravity circulation when the boiler switches off. Your Grant DuoWave unit has been supplied with a 2-port motorised valve, which will act as a positive energy cut-out should the safety cutout operate. Should this happen the motorised valve will operate and close down the primary flow to the cylinder. The valve should be wired in accordance with Figures 5-3, 5-5, 5-7, 5-9 or 5-11 depending on system design, to comply with current legislation.

This motorised valve will also control the temperature of the domestic stored water via the cylinder thermostat, which is located in the upper dual thermostat. The unit should be installed on a "S" or "Y" plan system as shown in Figures 5-2, 5-4 and 5-6.

# 5 Electrical Installation

5.5 'Y' Plan System Schematic and Wiring Diagram - DuoWave Indirect Solar Cylinder and Boiler

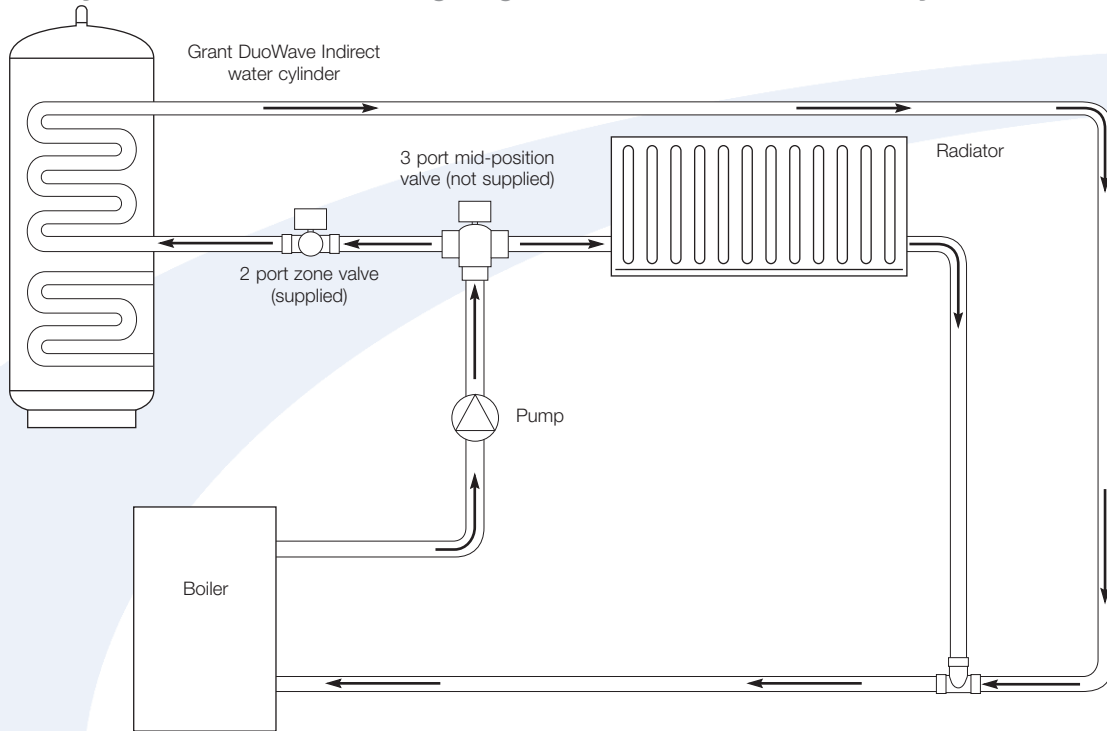

Figure 5-2: 'Y' Plan system schematic

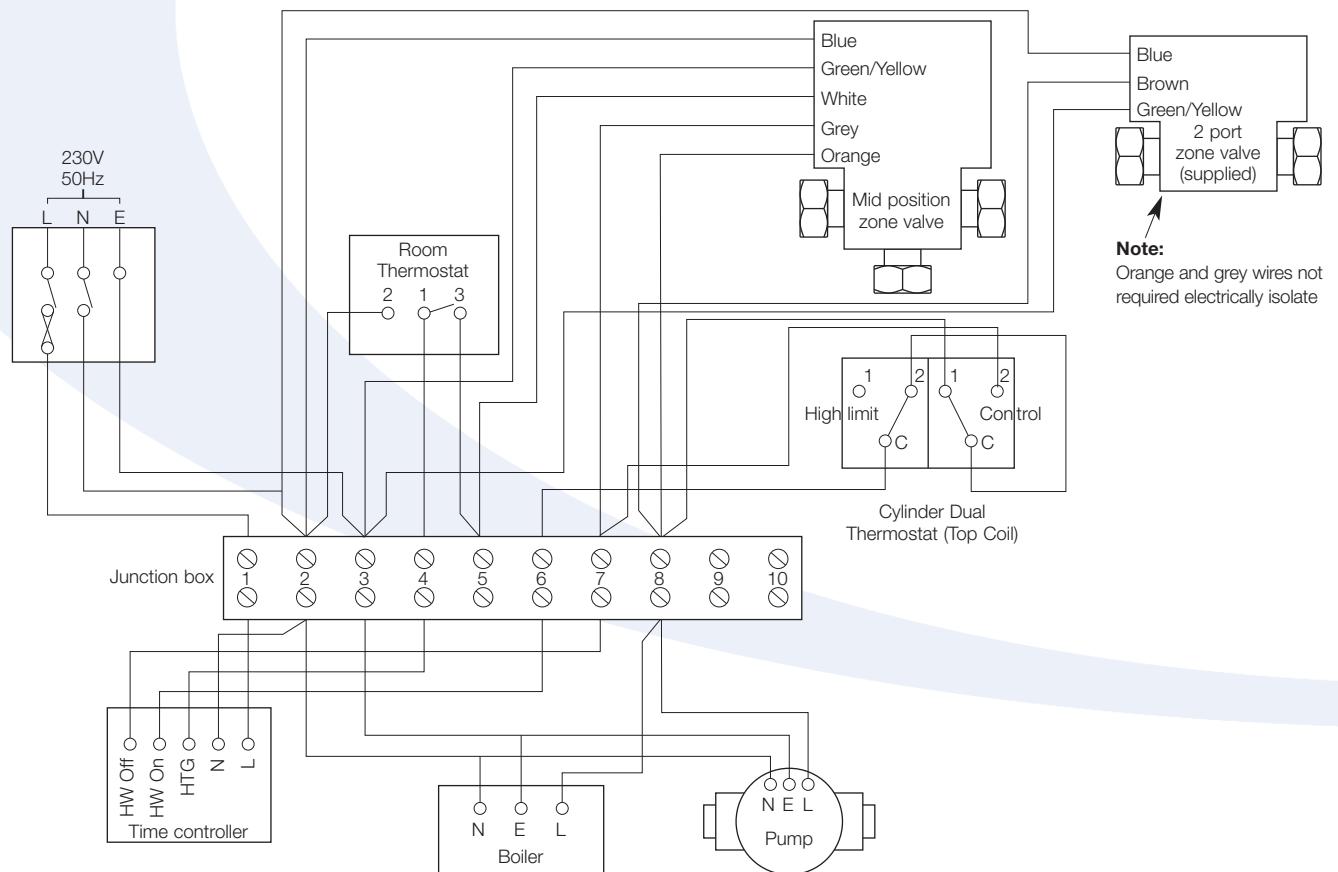

Figure 5-3: 'Y' Plan wiring layout

### 5.6 'S' Plan System Schematic and Wiring Diagram - DuoWave Indirect Solar Cylinder and Boiler

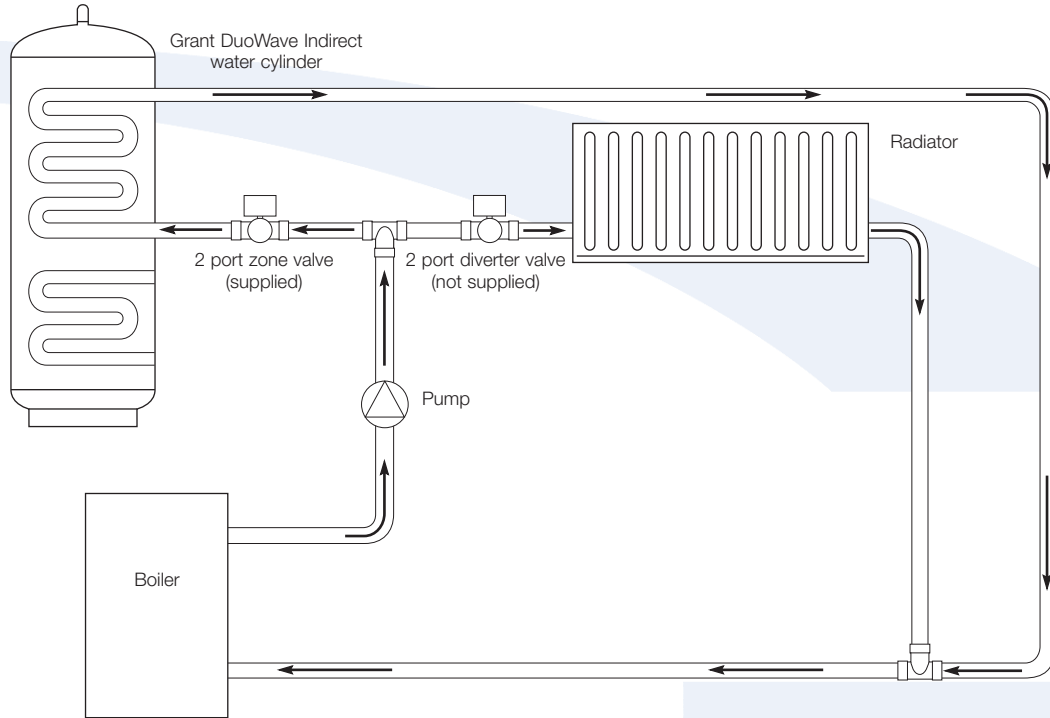

Figure 5-4: 'S' Plan system schematic

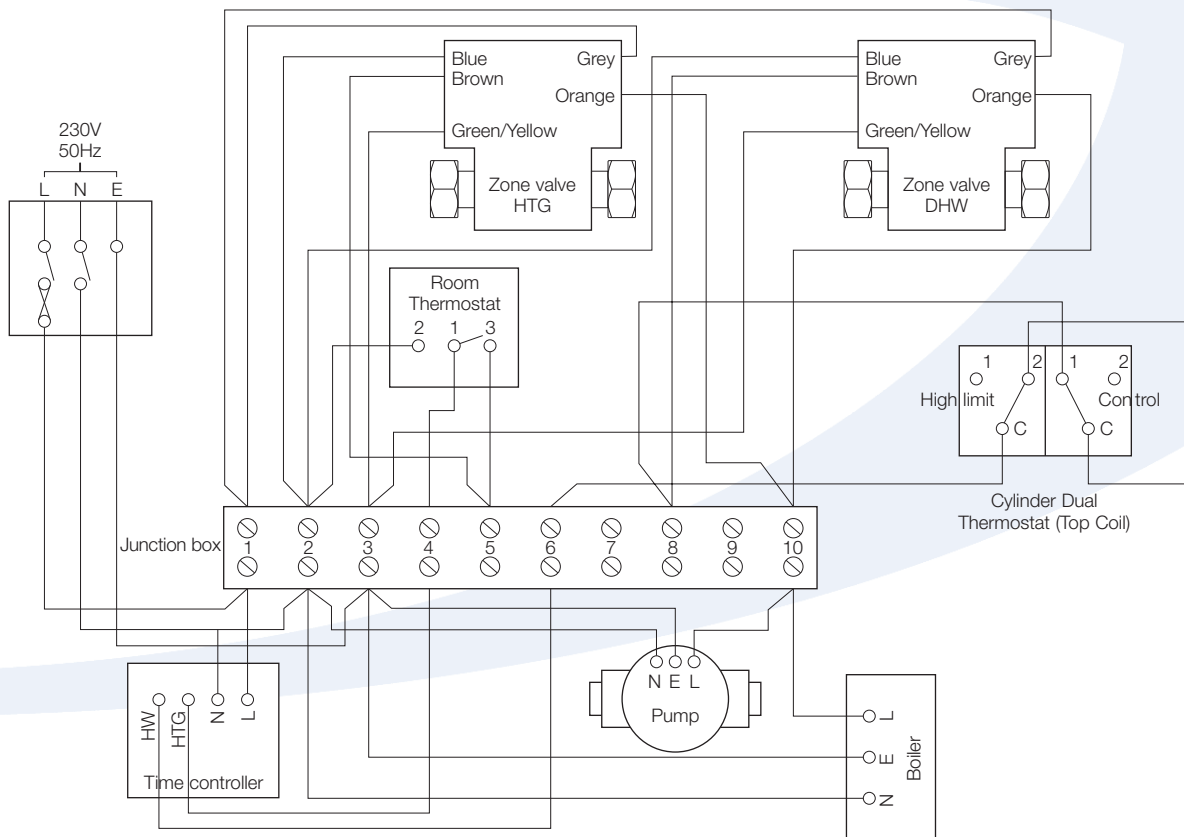

Figure 5-5: 'S' Plan wiring layout

# 5 Electrical Installation

## 5.7 Solar Thermal Schematic and Wiring Diagram

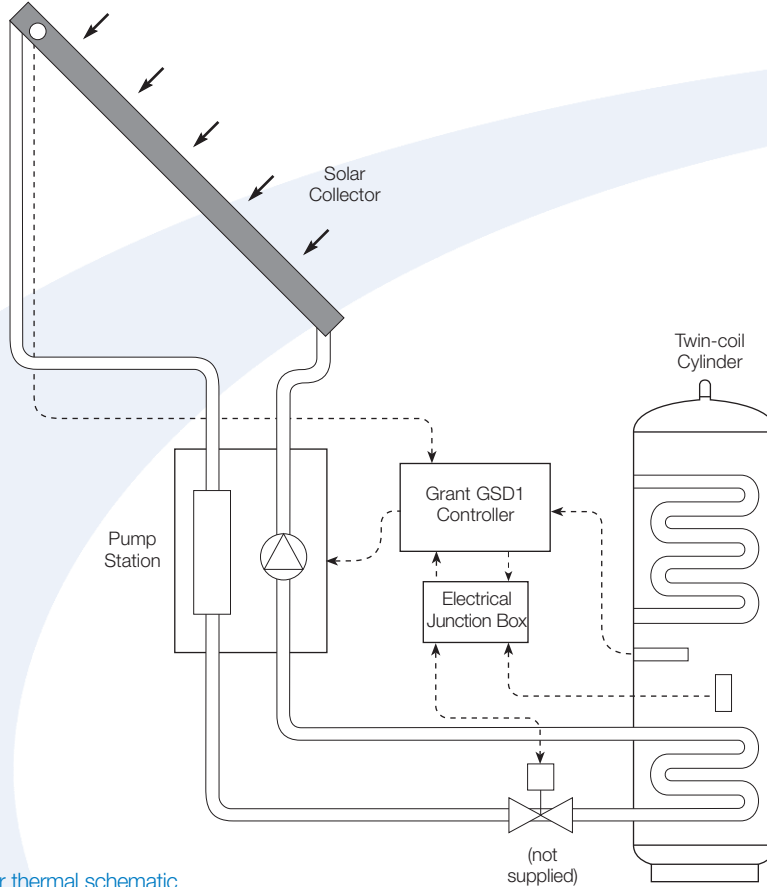

Figure 5-6: Solar thermal schematic

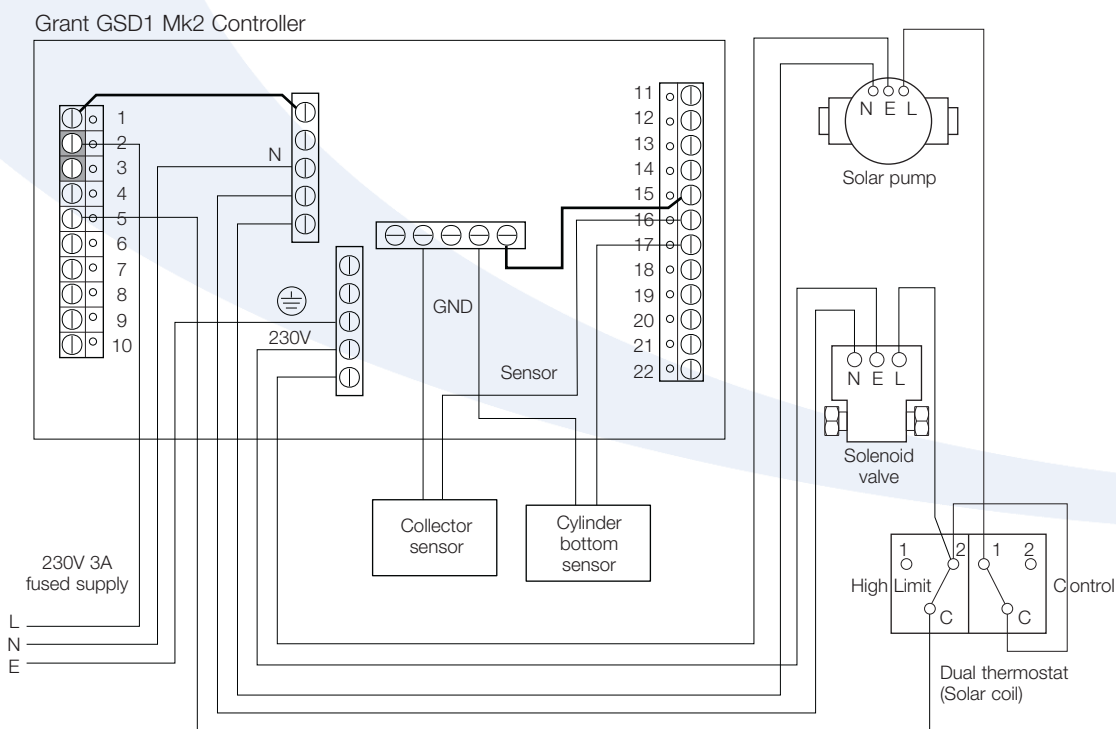

Figure 5-7: Solar thermal system typical wiring layout

# 6 Commissioning, Draining Down & Safety

## 6.1 Filling the Cylinder

### IMPORTANT

Before filling the cylinder check that the immersion heater has not loosened in transit. Tighten as necessary using a shaped spanner. Stillsons or pipe grips should **not** be used.

1. Open all hot water taps.
2. Turn on the stop cock.
3. When water flows from all taps close the taps.
4. Allow system to stabilise for five minutes.
5. Open each hot water tap in turn to expel air from the system pipe work.
6. Check for leaks.
7. Manually operate Temperature and Pressure Relief Valve (16) - Figures 2-4 to 2-6, to ensure free water flow through discharge pipe. (Turn knob to left).

## 6.2 Draining Down

Switch the electrical power off (important to avoid damage to element). Isolate boiler from DuoWave unit.

Turn off the cold water supply valve (stop cock). Open hot water taps. Open drain (20) - Figures 2-4 to 2-6. The unit will drain.

## 6.3 Safety Cut-Out

1. The safety cut-out operates if:
  - a. Wiring is incorrect.
  - b. The immersion heater thermostat or cylinder thermostat fails.
  - c. Thermostat is set too high.
2. Remember before resetting the safety cut-out or altering the thermostat setting, isolate electrical supply to the unit prior to removal of the electrical box lid.

3. Reduce thermostat setting and press the reset button. After adjustments are completed, ensure the lid to the electrical box is replaced correctly and the retaining screw is fitted.
4. If the problem persists, please contact your installer in the first instance.

## 6.4 Cold Water Discharge from Tundish

There are two reasons why cold water will discharge from the tundish:

1. The pressure reducing valve has malfunctioned (This will cause a large volume of water to flow through the tundish).
2. The Expansion relief valve is letting by (This will cause a very low volume of water to flow through the tundish).

In both cases, identify the defective component and replace. All repairs must be carried out by a competent person.

## 6.5 Hot Water Discharge from Tundish

There are four reasons why hot water will discharge from the tundish:

1. Thermal cut-out has malfunctioned.
2. The control thermostat has malfunctioned.
3. The T & P valve is letting by.
4. The expansion vessel has failed or lost its charge.

In all cases, should a repair be necessary, the work must be carried out by a competent person.

**Isolate the cylinder from all electrical supplies before commencing maintenance work.**

## 6.6 Expansion Vessel

1. The expansion vessel is connected into the cold water supply to the cylinder using the flexible hose. Flexible hose not supplied with 50 litre vessel. This vessel is connected using rigid pipe. Refer to Section 4.3.

### Note:

No valve should be fitted between the expansion vessel and the supply pipe.

2. Ensure that the air charge in the vessel matches the pressure setting shown on the pressure reducing valve.
3. The expansion vessel must be installed even if an accumulator is fitted.
4. The charge of the vessel must be checked at every annual service.

## 6.7 Customer Handover

1. Explain the operation of the system to the User, referring to Section 10 of these instructions.
2. In particular, make the User aware of what to do if water is seen to flow from either the T&P Valve or Expansion relief Valve. Refer User to the Information given in Section 10.

# 7 Maintenance

## 7.1 Servicing and Maintenance

1. Servicing and maintenance must only be carried out by a competent unvented hot water installer, or by Grant Engineering (IRL) Ltd authorised personnel.
2. Before any work whatsoever is carried out on the installation, it MUST first be isolated from the main's electricity supply.



**Both the primary and secondary systems will contain very hot water that will scald; therefore care should be taken when opening any joints, seals or valves.**

3. Only use spare parts authorised by Grant Engineering (IRL) Ltd. The use of unauthorised spare parts will invalidate the warranty.
4. Drain the cylinder – When draining the cylinder, always switch off the boiler and the immersion heater first. Turn off the water supply at the mains stopcock.  
  
Connect a hose pipe to the drain cock (see Figures 2-4 to 2-6) and route it to a convenient gully. Open the drain cock and all hot taps that are served by the cylinder. The cylinder may take several minutes to empty completely.
5. In hard water areas it may be necessary from time to time to remove and de-scale the immersion heater element. Replace the gasket each time it is removed.
6. Remove the cartridge from the pressure-reducing valve (PRV). Check the strainer and if necessary remove any debris from in front of it. Replace the cartridge. Refer to section 7.3 on the right.
7. Check the charge pressure in the expansion vessel and top up as necessary. The charge pressure should be 3.0bar. Refer to section 7.5 on the right.

8. Whilst the hose pipe is connected, the drain cock open and with the immersion heater removed, the cylinder may be flushed out to remove any debris, sand or lime scale particles that may have collected in the bottom by using a further hose pipe connected to the cold water main.
9. Close the drain cock, disconnect the hose, refit the immersion heater and close all hot water taps before reopening the stopcock. Allow the cylinder time to fill whilst checking for any leaks. Release any air from the system by opening each hot water tap individually, starting with the one furthest from the cylinder.
10. Manually lift the expansion relief and temperature and pressure relief valve one at a time, every 12 months (more frequently in hard water areas) to prevent debris from building up behind the valve seat. Whilst carrying out this operation, check that the discharge to waste is unobstructed. Check that each valve seals correctly when released. As the valves are pre-calibrated, they require no further maintenance.
11. Finally switch on the mains electricity supply to the immersion heater and the boiler. As the system heats up, check again for any leaks and rectify as necessary.

## 7.2 Manifold Assembly

The manifold assembly should not, under normal circumstance, require any maintenance. During annual servicing it may be necessary to inspect and/or clean the line strainer, the pressure reducing valve cartridge, expansion relief valve cartridge. The frequency of cleaning will depend on the local water conditions.

## 7.3 Pressure Reducing Valve

1. Isolate the cold water supply.
2. Unscrew the retaining nut of the valve. The complete operating mechanism, including the strainer can be removed.
3. Clean the filter mesh and the cartridge under running water.
4. Replace cartridge ensuring that strainer is correctly located and reassemble the unit. Pressure Reducing Valve cartridge and strainer Part No. GCS07C - 3.0 bar.

## 7.4 Expansion Relief Valve Cartridge

1. Isolate the cold water supply.
2. Remove grub screw (Allen Key type) from body of valve and withdraw valve ensuring not to damage O-ring.
3. Clean valve seat face and seating - do not scratch or damage either seat face or seating.
4. Refit in reverse order. Do not overtighten. Expansion valve cartridge Part No. GCS08.

## 7.5 Expansion Vessel

1. Isolate the cold water supply.
2. Open hot water taps.
3. Drain cylinder to below tee piece take off for expansion vessel flexible hose.
4. Replace expansion vessel after first checking the air charge (and hose if required).
5. Close drain off cock and turn on cold water supply.
6. When water is flowing freely from taps close taps.



# 8 Fault Finding Guide

## 8.1 Intermittent Water Discharge

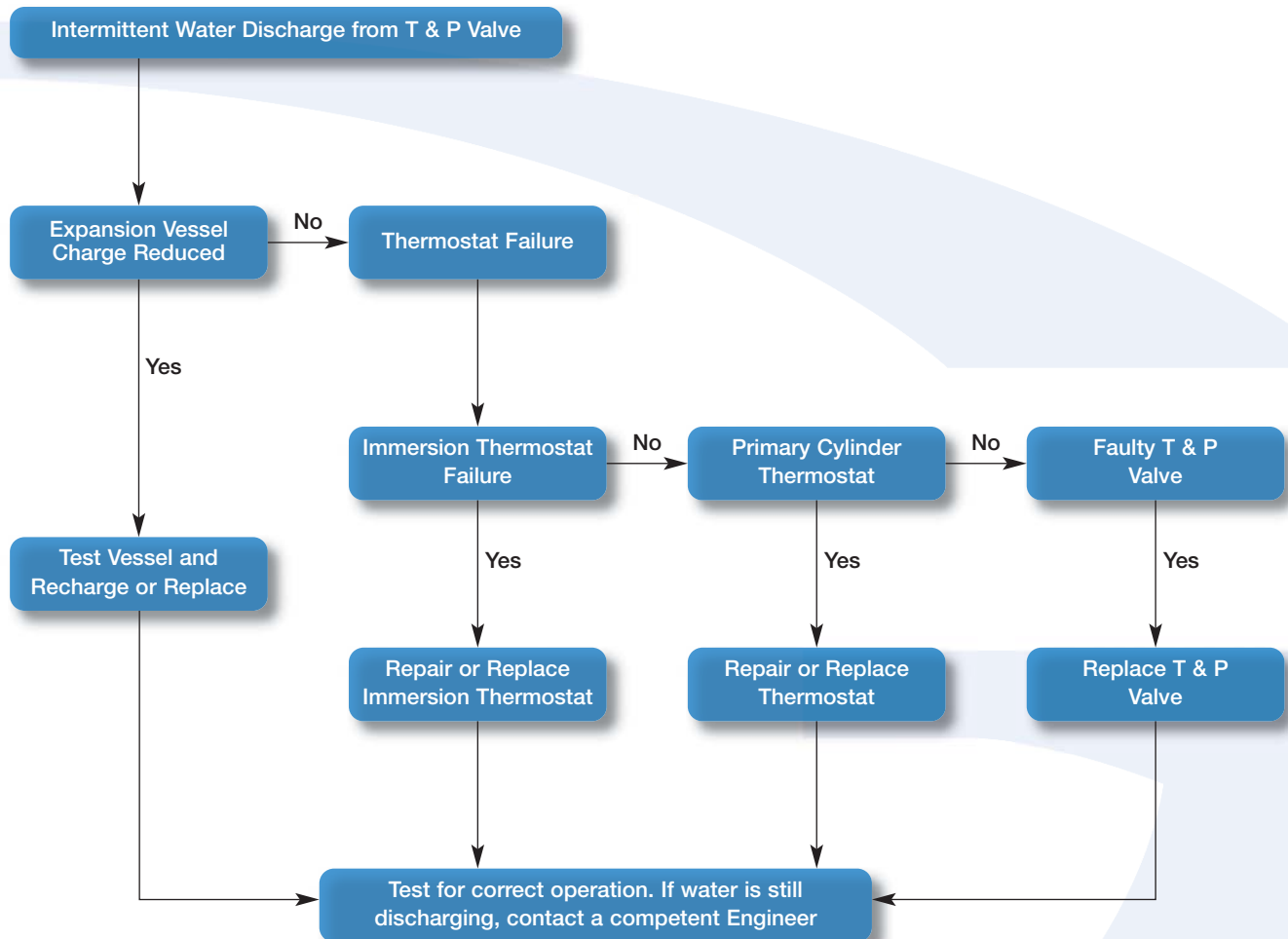

# 8 Fault Finding Guide

## 8.2 Constant Water Discharge

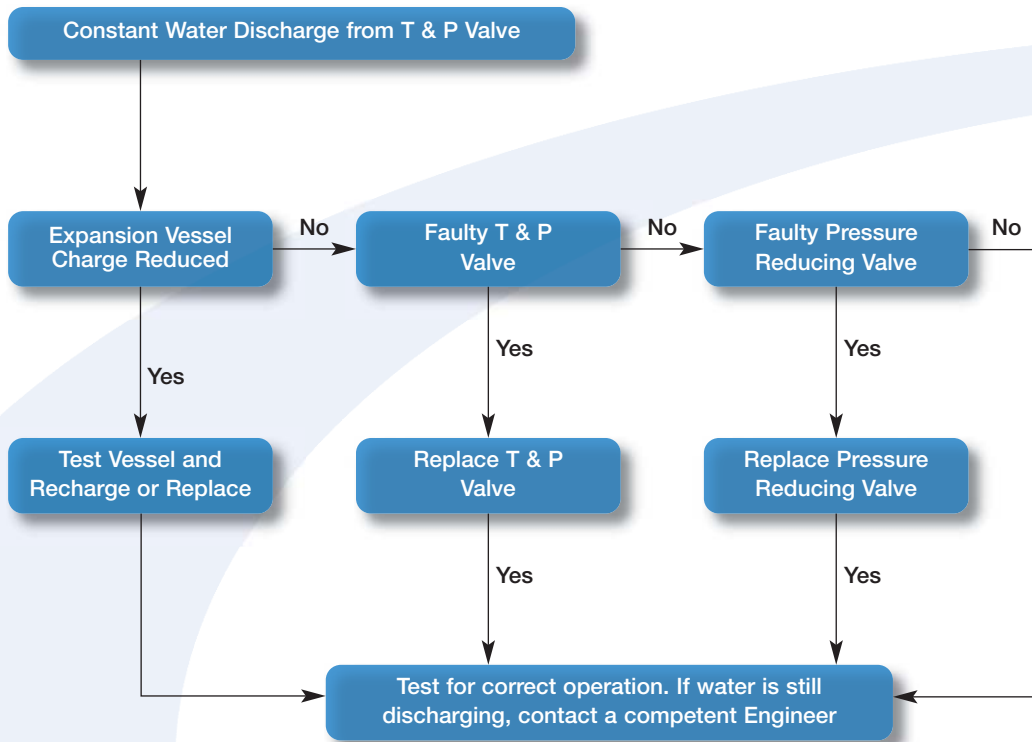

## 8.3 No Flow from Hot Water Taps

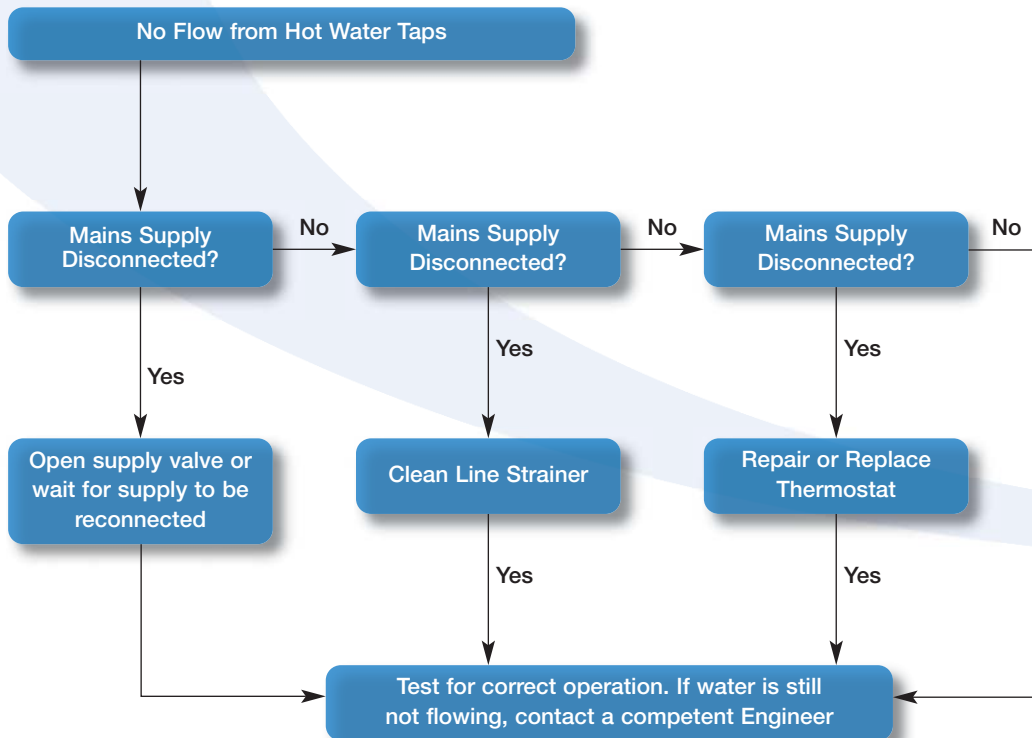

### 8.4 Cold Water Flow from Hot Water Taps

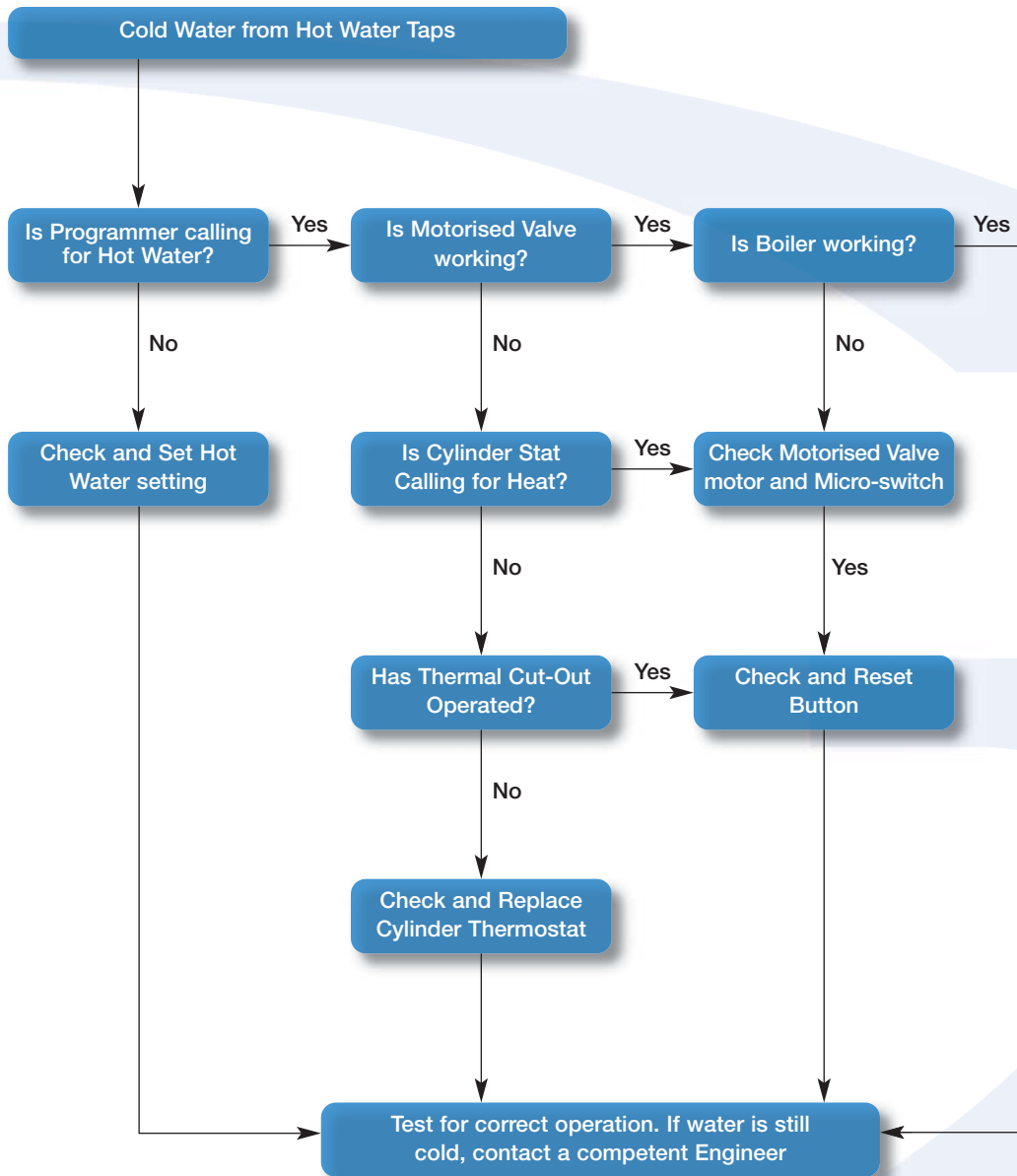

# 8 Fault Finding Guide

## 8.5 Excessive Hot Water from Taps

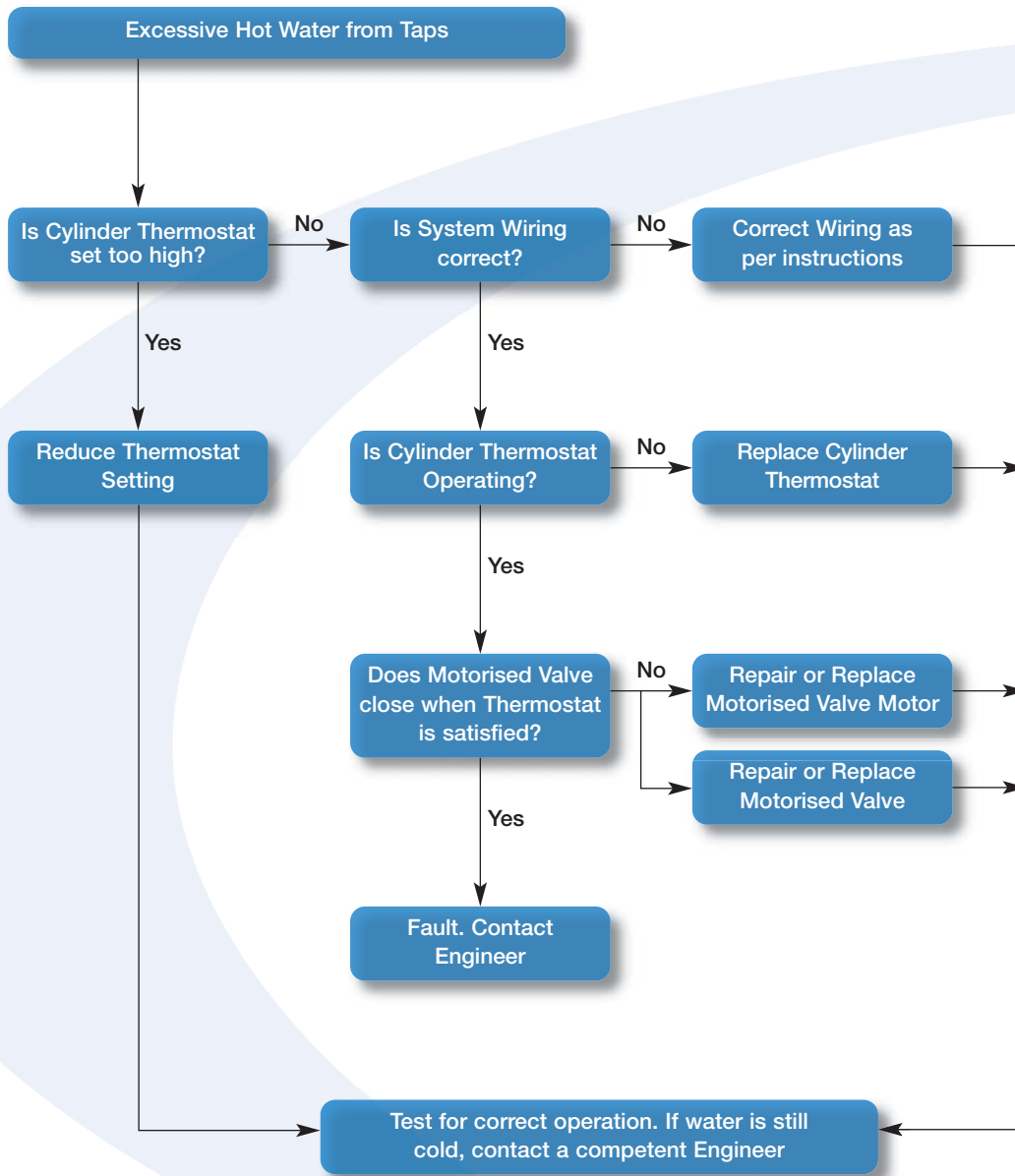

# 9 Spare Parts

## 9.1 Spare Parts



**Figure 9-1:** Pressure Reducing Valve (Cartridge and Strainer) - 3 bar



**Figure 9-3:** Inlet Manifold including pressure reducing valve, expansion relief valve



**Figure 9-5:** Flexible Hose



**Figure 9-2:** Tundish



**Figure 9-4:** Expansion Relief Valve (Complete) - 6 bar



**Figure 9-6:** Expansion Vessel

### DuoWave Indirect Cylinder Spare Parts

Part Name	Part No.
Pressure Reducing Valve - 3 bar	GCS32
Expansion Relief Valve - 6 bar	GCS08
Flexible Hose - 3/4" BSPF x 3/4" BSPM	GCS02
1/2" Temperature & Pressure Relief Valve 90°C/7 bar	GCS09
Tundish - 15mm/22mm Compression	GCS10
Coil Control/Limit Thermostat	GCS11
Immersion Heater Element - Cotherm type ELE14-IN-800-UNV	GCS30
Drain Cock	GCS14
Immersion Heater Thermostat - Cotherm type TSE	GCS31
Motorised Valve	GCS16
Expansion Vessel 19 litre nominal (170, 200 & 250 models)* (18 litre actual vol) - 3/4" BSPM connection	GCS24
Expansion Vessel 24 litre nominal (300 model)* (22 litre actual vol) - 3/4" BSPM connection	GCS25
Expansion Vessel 35 litre nominal (400 model)* (35 litre actual vol) - 3/4" BSPM connection	GCS28
Expansion Vessel 50 litre nominal (500 model)* (50 litre actual vol) - 1" BSPM connection	GCS27
1" BSPF x 3/4" BSPM Adaptor - for 35 litre Expansion Vessel	GCS33
Inlet Manifold c/w 3 bar Pressure Reducing Valve and 6 bar Expansion Relief Valve	GCS07

\*All pre-charged to 3 bar

# 10 User Instructions

## 10.1 User Instructions

1. Your Grant DuoWave Solar or unvented hot water cylinder has been designed to give many years of trouble-free service and is made from hygienic high grade stainless steel.
2. The flow temperature of the hot water can be set to your requirements on the immersion heater up to 60°C and the indirect system dual thermostat up to 65°C. These temperatures should not be set any higher otherwise nuisance tripping of the high limit thermostat will occur. If you are in any doubt, these adjustments should be best left to a qualified electrician.
3. When a hot tap is turned on there may be a short surge of water, this is quite normal with unvented systems and does not mean there is a fault.
4. When you first fill a basin the water may sometimes appear milky. This is due to very tiny air bubbles in the water, which will clear very quickly.



If water is seen to flow from either the Temperature & Pressure Relief (T&P Valve) valve or the Expansion Relief Valve (EV) on the cylinder seek expert advice immediately.

If the water is flowing from the T&P Valve, immediately:

Shut off the electrical supply to the immersion heater(s)

Shut down the boiler

Switch off ALL other heat sources to the cylinder e.g. solar, etc.

**DO NOT SHUT OFF THE WATER SUPPLY TO THE CYLINDER.**

Contact your installer to check the system.

### IMPORTANT

Do NOT tamper with any of the Safety controls fitted to the cylinder. If you suspect a fault always contact a **COMPETENT** installer who is **QUALIFIED** to work on unvented water cylinders.

# 11 Warranty

## 11.1 The Grant Cylinder Warranty

### Dear Customer

You are now the proud owner of a Grant Cylinder from Grant Engineering (IRL) Ltd, which has been designed to give you years of reliable, trouble free operation.

Grant Engineering (IRL) Ltd guarantees all electrical and mechanical components supplied with the cylinder for a period of one year from the date of purchase. In addition, the stainless steel used in the manufacture of the cylinder is guaranteed for a period of twenty five years with the manufacturing process of the cylinder guaranteed for one year from the date of purchase, provided that the cylinder is installed in full accordance with the installation instructions provided and the system is serviced after twelve months operation. (see Terms and Conditions).

### Breakdown during the Manufacturer's Warranty

If your Grant Cylinder should fail during the first year, you must contact Grant Engineering (IRL) Ltd, who will arrange for the repair under the terms of their Warranty, providing that the system has been correctly installed and commissioned and the fault is not due to misuse, or the failure of any external components not supplied by Grant Engineering (IRL) Ltd (e.g. pipework, etc.).

### In the first Instance:

Contact your installer or commissioning engineer to ensure that the fault does not lie with the system or any other components, or any incorrect setting of the system controls.

### If a Fault is Found:

Ask your installer to contact Grant Engineering (IRL) Ltd, Service Department on 057 9120089 who will arrange for a qualified service engineer to attend to the fault.

### Free of Charge Repairs:

During the first year no charge for parts or labour will be made providing that the Cylinder has been installed and commissioned correctly in accordance with the manufacturer's instructions. Proof of 'purchase' date must be provided upon request.

### Chargeable Repairs:

**A charge will be made if the cause of the breakdown is due to any of the following:**

- **Faults caused by the plumbing or heating system, external electrics and external components.**
- **The Grant Cylinder has not been commissioned, or serviced in accordance with the installation and servicing manual.**
- **The system has been installed for over one year.**

### Terms of Manufacturer's Guarantee

1. The Grant Cylinder guarantee starts from the date of purchase.
2. All electrical and mechanical components supplied with the Grant Cylinder are guaranteed for a period of one year. The stainless steel used in the manufacture of the cylinder is guaranteed for a period of twenty five years with the manufacturing process of the cylinder guaranteed for one year.

3. The Grant Cylinder must be installed by a competent/licensed installer and in accordance with the Codes of Practice and Regulations in force at the time of the installation.
4. The Grant Cylinder and its components must not have been modified or tampered with.
5. The installation must be serviced every twelve months as per the installation instructions. (Receipts should be kept as proof).
6. **The Grant Cylinder must be connected to a mains water supply (installations utilising a private water supply are not covered by this guarantee).**
7. Breakdown/failure due to lime-scale will not be covered by this guarantee.
8. The Grant Cylinder must not be sited in a location where it may be subjected to frost.
9. All claims under this guarantee must be made to Grant Engineering (IRL) Ltd prior to any work being undertaken. Proof of purchase and date of installation must be provided on request. Invoices for call out/repair work by any third party will not be accepted unless previously authorised by Grant Engineering (IRL) Ltd.
10. This guarantee is transferable providing the installation is serviced prior to the dwelling's new owners taking up residence.
11. Grant Engineering (IRL) Ltd will endeavour to provide prompt service in the unlikely event of a problem occurring, but cannot be held responsible for any consequence of delay however caused.
12. This guarantee applies to Grant Cylinders installed in the Republic of Ireland and Northern Ireland. Provision of in-warranty cover elsewhere is subject to agreement with Grant Engineering (IRE) Ltd.



**GRANT ENGINEERING (IRELAND) LTD**

Crinkle, Birr, Co. Offaly, Ireland

Tel: (057) 91 20089 Fax: (057) 91 21060 Email: [info@grantengineering.ie](mailto:info@grantengineering.ie) [www.grantengineering.ie](http://www.grantengineering.ie)

This manual is accurate at the date of printing but will be superseded and should be disregarded if specifications and/or appearances are changed in the interests of continued product improvement.  
All goods sold are subject to our official Conditions of Sale, a copy of which may be obtained on application. © Grant Engineering (Ireland) Limited 2008. No part of this manual may be reproduced by any means without prior written consent.